

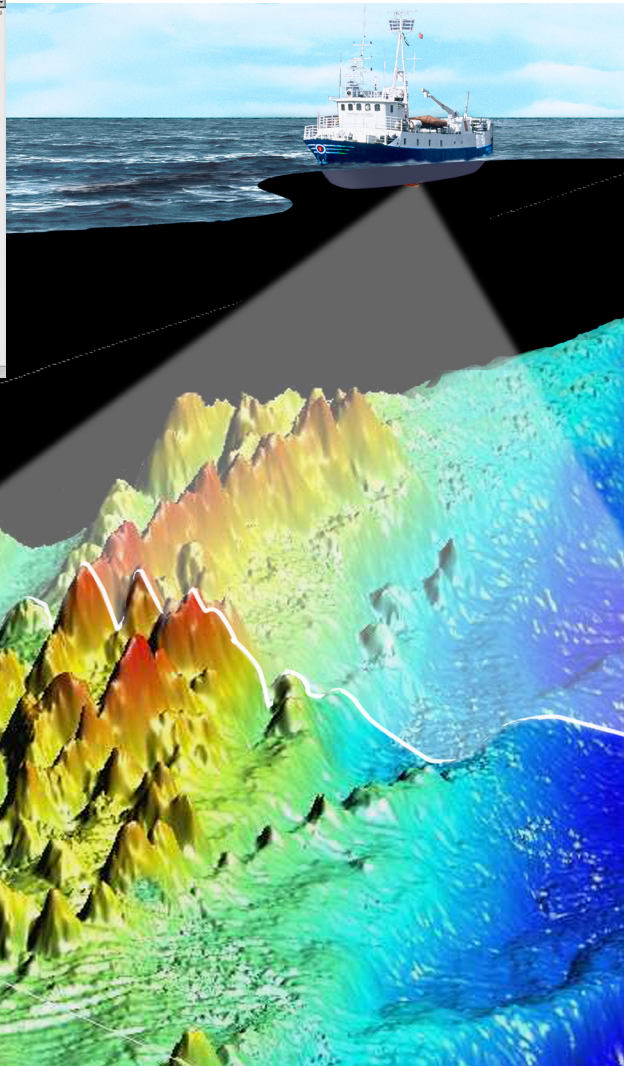

KONGSBERG

Reference Manual

SIS Seafloor Information System EM 2040

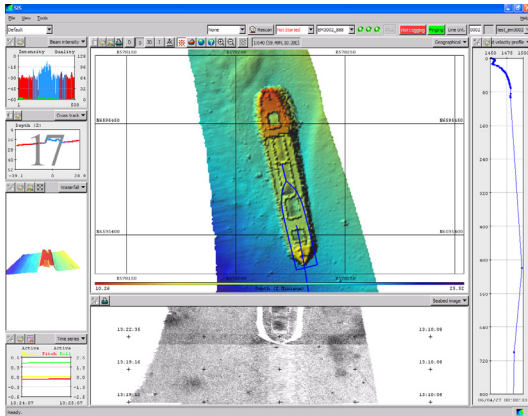



KONGSBERG

Seafloor Information System ***SIS***

Reference manual for EM 2040

Release 4.0

342682/D

October 2013 © Kongsberg Maritime AS

Document history

Document number: 342682		
Rev. A	February	Reference Manual for SIS with EM 2040. Applies to SIS version 3.7.
Rev. B	June 2010	Reference Manual for SIS with EM 2040. Applies to SIS version 3.8.
Rev. C	November 2010	Reference Manual for SIS with EM 2040. Applies to SIS version 3.8. Display and parameter updates. Applies to Windows XP and Windows 7.
Rev. D	October 2013	Reference Manual for SIS with EM 2040. Applies to SIS version 4.0.

Copyright

The information contained in this document remains the sole property of Kongsberg Maritime AS. No part of this document may be copied or reproduced in any form or by any means, and the information contained within it is not to be communicated to a third party, without the prior written consent of Kongsberg Maritime AS.

Disclaimer

Kongsberg Maritime AS endeavours to ensure that all information in this document is correct and fairly stated, but does not accept liability for any errors or omissions.

Warning

The equipment to which this manual applies must only be used for the purpose for which it was designed. Improper use or maintenance may cause damage to the equipment and/or injury to personnel. The user must be familiar with the contents of the appropriate manuals before attempting to operate or work on the equipment.

Kongsberg Maritime disclaims any responsibility for damage or injury caused by improper installation, use or maintenance of the equipment.

Table of contents

ABOUT THIS MANUAL	13
SIS SYSTEM DESCRIPTION	15
Basic description	15
SIS system information	16
C-Map installation notes.....	16
SIS licences	16
System drawing	17
SIS system overview	18
SIS operational principles	21
SIS as a controller.....	22
GRAPHICAL USER INTERFACE	25
The application window	25
SIS frames	27
Toolbars	33
Main toolbar.....	33
Frame toolbars.....	35
Echo sounder – Not started list	35
Current echo sounder	36
Line counter toolbar set.....	37
View menu.....	38
Tear-off windows.....	39
Icons.....	40
C-MAP detail level	41
Colour palette.....	41
Status bar	42
Keyboard and mouse operations	43
Keyboard and mouse in the Geographical view.....	44
Keyboard and mouse in the Planning module view.....	44
Keyboard and mouse in the Sound velocity profile view	45
Keyboard and mouse in the Waterfall view	45
Keyboard and mouse in the Sensor layout view	45
Keyboard and mouse in the Water column view	46
Keyboard and mouse in the Calibration view	46
Hotkeys.....	46
File storage locations used by SIS.....	47
Common display buttons.....	48
Annotation colours button	49
Dynamic colours button	50

Print button	51
Zoom and view buttons	51
Scale buttons	53
WINDOWS AND VIEWS	55
Geographical view	57
Beam intensity view	61
Colour coded depth view	63
Cross track view	64
Seabed image view	66
Numerical display	68
Message service view	69
Helmsman display view	70
Time series view	72
Waterfall view	73
Water column view	75
Sound velocity profile view	79
Scope display	81
Stave display	83
PU sensor status view	86
New survey window	89
Survey administration window	91
Planning module window	93
Installation parameters window	94
Runtime parameters window	95
Runtime parameters mini view	96
Sensor layout view	98
Calibration view	100
THE MENU SYSTEM	103
Main menu	103
File menu	104
View menu	105
Tools menu	105
Custom menu	106
Help menu	107
OPERATIONAL PROCEDURES	108
Normal operational sequence	110
Start SIS	112
Enter survey and operator parameters, set projection	113
Set survey parameters	114
Start a new survey	118

Define a projection and datum transformation	122
Check installation and runtime parameters	125
Installation parameters	126
Runtime parameters	133
External sensors.....	136
Enter a sound velocity profile.....	139
Start the echo sounder	154
Import a Neptune grid to SIS	159
Start pinging	160
Check sensor input	160
Check echo sounder main functions.....	161
Geographical frame settings.....	162
Start and stop logging.....	169
Perform a system calibration.....	171
How to determine calibration values using SIS Calibration frame	181
How to determine calibration values using SeaCal automatic calibration	184
How to calibrate a dual head system.....	188
Plan a survey	199
Run the survey.....	202
Export data	206
Remote Helmsman Display.....	206
Exporting survey results.....	207
Exit SIS.....	207
PARAMETER REFERENCES	209
Frame toolbars parameters	209
Geographical – Display options	211
Geographical – Show depth under cursor.....	222
Geographical – Grid shading	222
Geographical – 2D or 3D.....	223
Geographical – Inspection mode	223
Geographical – Compass button.....	223
Geographical – KSGPL edit mode	223
Geographical – Planning edit mode.....	224
Geographical – Calibration edit mode	224
Geographical – Follow ship.....	224
Geographical – Load background data.....	224
Geographical – Save background image.....	224
Geographical – C-MAP manipulation mode	225
Geographical – Information field	225
Geographical – Level of Detail	225
Beam intensity – Show/hide	227

Colour coded depth – Show/hide.....	227
Cross track – Display options	227
Seabed image – Show/hide	231
Numerical display	232
Helmsman display – Show/hide	237
Time series – Show/hide.....	238
Time series – Clear plot.....	241
Waterfall – Show/hide.....	241
Water column – Show/hide.....	243
Water column – Logging	247
Sound velocity profile – Show/hide.....	247
Scope display – Show/hide	247
Stave display – Show/hide.....	249
Planning – Jobs.....	251
Planning – Remote.....	251
Planning – Object	251
Sensor layout – Show/hide	258
Calibration parameters	260
Seacal auto calibration	261
Survey parameters	263
Basic parameters.....	263
Storage options.....	265
Background data.....	267
Projection parameters.....	269
GridEngine parameters.....	269
User handling	272
CUBE parameters	273
Installation parameters	274
PU communication – Input setup	275
PU communication – Output setup.....	279
PU communication – Clock setup	281
Sensor setup – Settings.....	283
Sensor setup – Location for EM 2040.....	288
Angular Offsets for EM 2040	290
ROV Specific for EM 2040	291
System parameters for EM 2040	292
BIST – Built-In Self Test.....	293
System report	296
Runtime parameters.....	297
Sounder main for EM 2040	297
Sound speed for EM 2040	305
Filter and gains for EM 2040	310
Data cleaning.....	317

GPS and delayed heave	323
Simulator for EM 2040	329
Survey Information	332
SIS parameters – Set parameters	333
Ship parameters	334
Positions	335
Turn parameters	337
Password	338
Display	339
Logging	341
Autopilot	343
Sound speed	344
Network license	345
Error model parameters	346
APOS	347
Sensor options	348
Startup options for system	350
Projections	351
File menu parameters	352
Import/Export	352
Export xyz file	361
Remove survey	362
Remove sounder	362
Save settings	363
Save settings as	363
Delete settings	364
Set startup settings	364
Export PU parameters	364
Import PU parameters	366
Set PU factory settings	367
Export user settings	368
Import user settings	369
Create CUBE grid	369
Quit	370
Tools menu parameters	371
External sensors	371
Instrument combinations	377
Remove instruments	378
C-MAP – Licence administration	379
AutoCalib Wizard	380
SeaCal results	381
Extract IFF	381
Configure	382

Projection and datum parameters	384
Help menu dialogs.....	390
Help.....	391
Build info.....	391
OpenGL settings.....	392
About SIS.....	392
SIS UTILITIES	394
SVP Editor.....	395
Raypaths chart	401
User interface	401
What you see.....	404
SeaCast	405
What it does	405
How to install	405
How it works.....	405
SVP Logger	406
Running the program	406
Using the program	407
SeaCal.....	409
What it does	409
Calibration parameters	410
Design of the calibration lines.....	410
How to run SeaCal.....	412
Resolution.....	413
Maximum number of iterations.....	414
More on the field calibration method.....	414
Bibliography	415
SIS Objects	417
How to use SIS Objects.....	417
Configuration of SIS Objects	421
Technical references.....	425
File formats	426
Logging utilities	435
Logging of input on SIS sockets	435
Logging of input on PU sockets.....	438
C-MAP CM-93/3.....	443
What it does	443
Specification of minimum performance.....	443
C-MAP S-57 Verifier and CM-93/3 Compiler.....	443
The C-MAP Cartographic Service.....	445
Global event marker	447
PU simulator and playback.....	449

Create grid from ASCII files	451
KSGPL	453
Overview	453
KSGPL language reference	453
KSGPL output from the Geographical window	455
Input of S-57 formatted chart files	458
How to use SIS on an AUV/ROV	460
CUBE	464
About the implementation of CUBE in SIS	464
User interface differences when CUBE is used	470
Precise Point Positioning (PPP) in SIS	476
Precise Point Positioning (PPP) – General description	476
TerraPOS	477
How to do Precise Point Positioning in SIS	478
GSF support in SIS	483
How to use GSF Converter	483
TECHNICAL REFERENCES	486
SIS architecture	487
SIS processes	487
Main GUI (Graphical User Interface)	488
CCU (Central Command Unit)	489
DDS (Data Distribution System)	489
HDDS (Handle Data Distribution System)	489
GridEngine	490
SISDB	491
Real time data cleaning	492
The vessel coordinate system	496
Timing	498
Introduction	498
Internal clock	498
Time stamping	499
Time difference PU-ZDA and PU-POS indications	500
Sound speed formulas	502
Implementation of absorption coefficients	504
Overview	504
Salinity based absorption coefficient profiles	504
CTD based absorption coefficient profiles	506
Mode of operation	507
Artefacts causing errors and variations in the sea floor depth detections	509
Introduction	509
Sea bottom penetration	509
The absorption coefficient equation	512

Projections	513
Scope	513
Programming a projection	513
Using PROJ.4	513
Geoid	515
Tide	518
Javad and Trimble details	520
Raw GPS data logging module	520
Mean Sea level module	522
Real time tide module	522
RStoUDP	523
Dead reckoning and position jump filter	525
Dead Reckoning	525
Position jumps	525
Checking of legal beam pointing angles	527
DATAGRAM AND FILE FORMATS.....	529
TPU – Error estimate logging format.....	530
Export formats	531
Depth under keel output format.....	534
Depth profile output.....	535
Transmit depth profiles format	535
Terrain referenced position	536
Survey plan file format	538
Handling of SSP datagrams.....	539
Overview	539
Usage.....	541
Reception handling of SSP format input	542
Sound speed profile formats	544
ASVP format.....	544
Supported sound velocity probes.....	546
ACTD format	548
External datagram (C+T) format.....	550
ATH data format	551
SRH data format	555
TerraPOS data format	556
Changing behaviour of notification messages	558
Request datagrams from an echo sounder	559
Request datagrams – manual set-up	561
Data distribution	567
Remote datagrams	568
Notification of SIS pinging and logging activity.....	570

Difference in log file formats	573
Barometer input.....	574
Preparations for use	574
Barometer input format	574
K-Sync interface.....	575
Port allocation.....	576
A TERMINOLOGY AND ABBREVIATIONS.....	579
B INDEX (INTERACTIVE)	584

About this manual

This is the Reference manual for EM 2040 for the Seafloor Information System (SIS).

The purpose of this manual

The purpose of this reference manual is to provide full description of the procedures and parameters required to allow for safe and efficient use of SIS, as well as a thorough understanding of the system parameters and adjustments.

Note

The SIS Operator Manual is identical to the six first chapters of the SIS Reference Manual.

Please note that examples or illustration from a different echo sounder than yours may be given within this manual. This will however not be the case for the installation and runtime parameter descriptions applicable to your echo sounder.

Contents

- *SIS system description* on page 15 – gives a brief and general description of SIS and its use
- *Graphical user interface* on page 25 – description of the SIS user interface
- *Windows and views* on page 55 – presents all available SIS frames and their purposes
- *The menu system* on page 103 – presents the SIS menus
- *Operational procedures* on page 108 – contains detailed description on how to carry out different common SIS operations
- *Parameter references* on page 209 – contains detailed description of all parameter settings available from the frames and menus in SIS, including description of all EM specific runtime and installation parameters
- *SIS utilities* on page 394 – contains description of added functionality that comes with SIS
- *Technical references* on page 486 – in depth information about SIS
- *Datagram and file formats* on page 529 – contains file and datagram formats used in SIS

Software version

This manual complies to SIS software version 4.0.

Registered trademarks

Windows®, Windows XP®, and Windows® 7 are either registered trademarks, or trademarks of Microsoft Corporation in the United States and/or other countries.

EM® is a registered trademark of Kongsberg Maritime AS in Norway and other countries.

References

Refer to the following manuals for additional information about SIS. These manuals are available through **SISHelp**. Press the Windows **Start** button, select **All Programs**→**SIS**→**SISHelp** to access relevant SIS documents. The documents are also enclosed on your SIS installation DVD.

The documents provided are (document numbers in brackets):

- SIS Operator manual [164709]
- SIS Reference manual for EM 2040 [342682] – this manual
- EM Series datagram formats [160692]
- Software installation procedure [164891]
- SIS software release note [164890]

Support

Support Hydrography/Naval: km.hs@kongsberg.com

24 hrs support telephone: +47 99 20 38 01

All Kongsberg Maritime products (24 hours): +47 815 35 355

E-mail: km.support@kongsberg.com

SIS system description

Topics

- *Basic description* on page 15
- *SIS system information* on page 16
- *SIS licences* on page 16
- *System drawing* on page 17
- *SIS system overview* on page 18
- *SIS operational principles* on page 21
- *SIS as a controller* on page 22

Basic description

Seafloor Information System (SIS) is a real time software designed to be the user interface and real time data processing system for hydrographic instruments produced by Kongsberg Maritime AS. Today the echo sounders EM 3002, EM 3001, EM 3000, EM 2040, EM 2040C, EM 2000, EM 1002, EM 710, EM 302, EM 300, EM 122, EM 121A, EM 120, ME70/BO, EA 400 and EA 600 are supported. SIS is included on all deliveries of multibeam echo sounders from Kongsberg Maritime. The main task for SIS is to be an intuitive and user friendly interface for the surveyor, providing the functionality needed for running a survey efficiently.

SIS operates under the Windows operating system, and is compatible with the HWS (Hydrographic Work Station) operator PC hardware. Up to four screens can be used on one HWS, and SIS can also show geographical displays on several remote PCs in the network.

The Kongsberg Maritime echo sounders are complete systems. All necessary sensor interfaces, data displays for quality control and sensor calibration, seabed visualization, and data logging are standard parts of the systems, as is integrated seabed acoustical imaging capability (sidescan).

SIS system information

Operating systems supported:

- Windows XP™
- Windows 7™

Hardware supported:

- HWS
- 1 or 2 displays, optional 4 displays if a second video card is installed

Licence control:

- By dongle connected to USB port

Options/versions:

- Basic version – Instrument control
- Multibeam echo sounder support
- Real time data cleaning
- Water column imaging
- SIS Objects

C-Map installation notes

- C-Map is NOT automatically installed.
- To install C-Map, launch **InstallCMAP** from the Windows **Start** button, then select →**Programs**→**SIS**→**InstallCMAP** and follow the instructions.
- All menu items and the option to load C-Map charts in the Geographical display is enabled only when C-Map is installed and the file `enableCMAP.bat` in the SIS/bin folder has been run.

SIS licences

The SIS software is subject to license control. Licensing of SIS is controlled by a HASP dongle. This dongle is programmed according to what SIS version has been purchased.

The control part of SIS is unlicensed. This version gives access to the following applications:

- Installation and runtime parameters
- Start/stop logging
- Survey administration
- New survey
- Messages, Beam intensity, Cross track, Time series, Seabed image, Numerical display and Water column windows

An unlicensed version of SIS will also work as an interface to third party software.

System drawing

The figure below shows the principle drawing of the hardware setup with the SIS software package, integrated with single beam or multibeam echo sounder systems.

Figure 1 Principle drawing, hardware setup with SIS

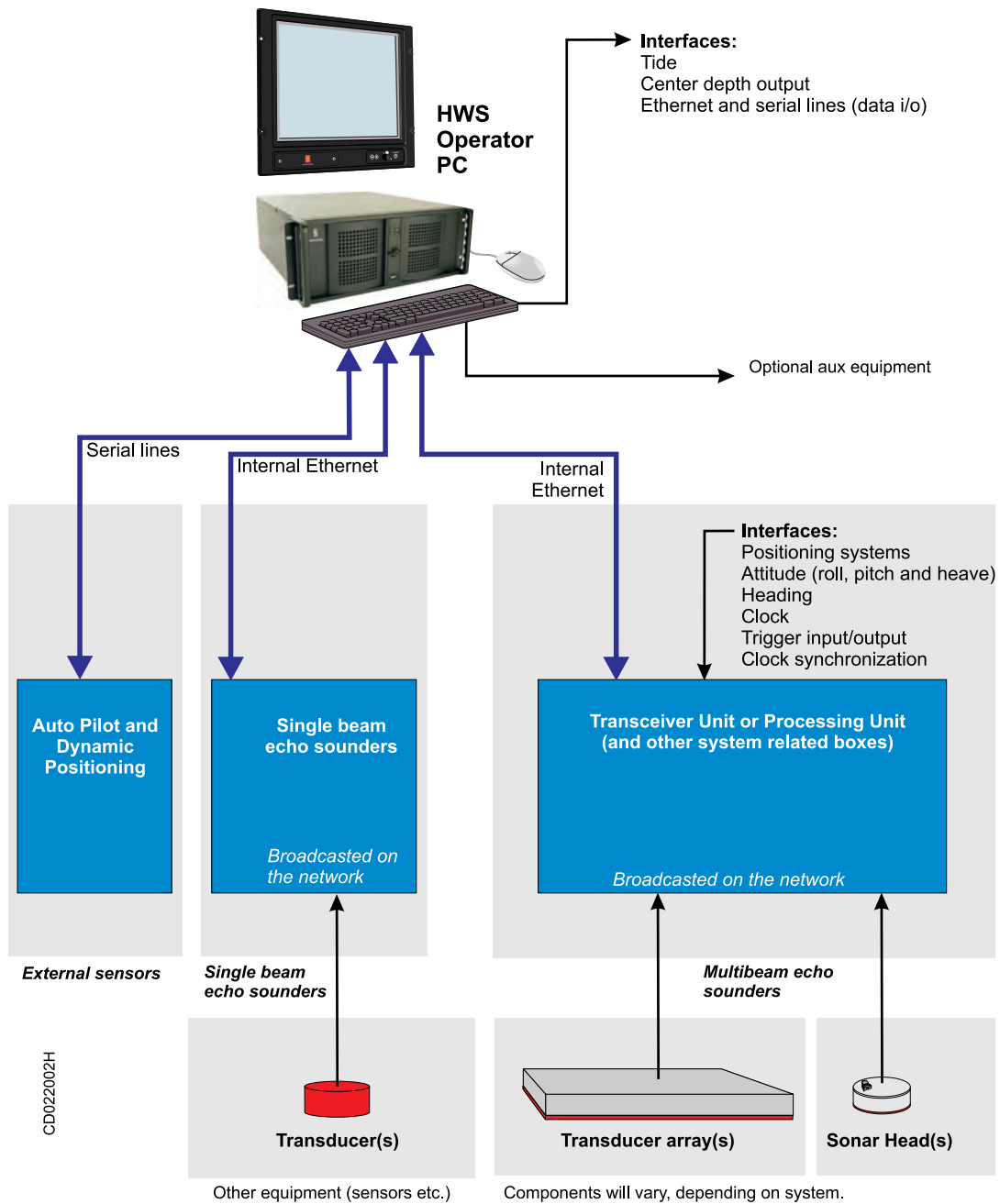

SIS system overview

The main task of SIS is to be a logical and user friendly interface for the surveyor, providing required functionality for running a survey efficiently.

Advanced features of SIS are:

- Control of several instruments simultaneously, both single- and multibeam echo sounders
- Screen layout with up to seven simultaneous display windows defined by the user
- Real time data cleaning of bathymetric data
- Enhanced functions for visual and automated data quality control
- Graphical displays for sound speed at sonar head and sound speed profile
- Built in health tests of the multibeam echo sounder and continuous monitoring the quality of input data. Error situations are logged, and user notifications are given advising what action to take.
- High resolution seabed image mosaic can be viewed in the Geographical view
- Unique features for plotting of scaled maps in size up to A0
- Imaging of acoustic reflectors in the water column (fish, biomass, etc.)
- Real time computation of the mean sea level using a geoid model
- Real time compensation for tide
- Fully operational when echo sounder is mounted on ROV/AUV
- Post processing of GNSS raw position data using Precise Point Positioning

Basic version – Instrument control

With the basic/instrument control version of SIS you can select which instrument to operate, turn it on/off, store data on/off, change setup and operating parameters and export data. There are graphical windows for quality checking of sensor input and the data produced. Sound speed at sonar head and sound speed profile input are interfaced and handled correctly in real time.

Multibeam echo sounders have built-in tests which can be activated to verify that the hardware is working correctly. In addition SIS constantly monitors input data to ensure the data quality. Error situations are logged and user notifications are given with advice of what action the operator should take.

Multibeam echo sounder support

Licensed multibeam support gives access to:

- More QA views for the multibeam data
- System calibration
- Visualisation of high resolution seabed backscatter data
- Visualisation of seabed imagery data in the Geographical view
- Plotting of survey results with full plotter resolution
- Support for remote Helmsman Display, connected via Ethernet

Geographical window

The Geographical window can display a terrain model in 2D and 3D mode. In 2D mode background maps can be displayed (DXF, C-MAP, KSGPL ascii files, GeoTIFF are supported), planned survey lines, a user defined vessel symbol, raw (limited) soundings and gridded (unlimited) terrain model. In 3D mode the seafloor surface can be viewed from different angles and in different resolutions, the light source can be shifted, and the surface can be rotated around all axis to obtain the best view.

The Geographical window can be zoomed and panned, and it can be set to follow the ship's position automatically.

Grid model from previous surveys can be imported and used as background information or used for comparison purposes.

A planning module makes it possible to define and edit planned lines, make parallel lines, define survey regions, etc. Plans can be imported and exported between systems.

Singlebeam echo sounder support

EA singlebeam echo sounders, from version 2.4.0.0 and onwards, have the ability to be used in a SIS compatible mode of operation. This will enable the EA echo sounder to be integrated in the SIS topside environment for control, display and data logging purposes.

From the SIS point of view an EA in SIS operational mode will behave as a traditional EM echo sounder except for some operational restrictions and a different data logging format.

An EA in SIS operational mode will broadcast it's presence on the network using port 1999. When detected by SIS it will be named EA600 and it can be started by SIS in the same manner as used for the EM range of echo sounders.

Only a small number of the different SIS information display frames will be active for the EA echo sounder. Most noteworthy, no installation and runtime parameter settings are currently available for this echo sounder. The numerical display will have a restricted function mainly showing position information, speed and depth. The major display for the EA operation in SIS will be the Geographical view frame. It is used to present the depth information in gridded format based on the logged data. The ship's position will be shown as a cross, as no heading is currently available in the EA position datagram.

The pinging and logging operation is controlled by the standard SIS buttons used for this purpose. The data being sent from the EA echo sounder, and logged by SIS, is processed data (i.e. not raw data).

Real time data cleaning

SIS includes highly efficient algorithms for automatic flagging of soundings which should be eliminated from the survey. The soundings are not removed, simply flagged as invalid so it is always possible to reverse the decision easily. For the majority of user needs, this processing will be satisfactory so that further processing is made either not necessary or at least substantially reduced.

The terrain model is generated in real time from input of all soundings available in one area, not just the current soundings, but all previous soundings in that area. The processing algorithm automatically chooses the best cell size, and then defines a curved surface through the majority of the soundings in that cell. This adaptive approach makes the processing very robust and “clouds” of invalid soundings (like schools of fish) can be flagged invalid automatically.

The gridding algorithm updates a multi-resolution display grid which makes it possible to select a grid with the best fit resolution to the selected map scale. Large areas can then be displayed with low resolution, but still important details can be shown. SIS can quickly zoom to smaller areas and display the terrain in full detail, even down to every single depth point.

Water column imaging

Some multibeam echo sounders, depending on model and purchased options, have built-in support for imaging of acoustic reflectors also in the water column. Such reflectors are for example fish or other biomass, but can also be submerged buoys or moorings.

Seabed image

SIS provides three views of seabed image data from multibeam echo sounders. In the first view, the user is presented with a classical time/across window where all seabed image is displayed along a time-axis. Second, in the Geographical window the user can see a low resolution seabed image mosaic by simply displaying reflectivity per display cell. Third, in Geographical window the user can call for a high resolution seabed image mosaic image to be displayed on top of the terrain. The resolution is typically 9 to 25 times higher than the maximum resolution of the bathymetric data.

GPS RTK and tide input

SIS provides users of GPS RTK systems to use geoid models in real time. The distance from the vertical reference to the seafloor, the distance from the geoid to the seafloor, and the distance from the ellipsoid to the seafloor are all calculated in real time. This eliminates heave and tide effects in the data in real time. Tide input can also be used in real time, either predicted tide from ascii files, or tide input from serial lines or network interfaces.

ROV operations

ROV operations are also supported in SIS. The depth of the ROV can be given to the echosounder in real time, and SIS will create a terrain model from the data collected by the ROV. Displays like Crosstrack and Waterfall are also useful when running an ROV survey.

SIS Objects

An addition to SIS makes it possible to add markers during survey. The user can define a set of lines, points, images and text to be displayed, and then the user can add such objects during survey. Such markers can be bouys, wrecks, shoals, coastlines, dryfall, etc. These objects can be exported to xml-files, and they can be read and displayed as background information later.

Precise Point Positioning in SIS

SIS integrates logging of raw GNSS observations from the Seapath 300 system. This data can be post-processed by applying more precise GNSS clock and orbit information to give very precise positions, typically in the sub-decimetre range, without use of GPS reference signals. This utilizes the TerraPOS software (by TerraTec) to compute the high accuracy position data. The process is highly automated in SIS and easy to use.

SIS operational principles

Note

The SIS software is used by single beam or multibeam echo sounders. When you run a survey, you can log data from more than one system at a time. This implies that not all information herein will be relevant for all systems. This is further explained in the following.

SIS is operated in *Online* or *Offline* mode.

- The *Online* mode is used during the survey. The application is used to control the (multibeam) echo sounder, to store the data, and to present various views of the data for quality assurance.
- The *Offline* mode is used after the survey has been completed, and the data is stored on disk. The application is used to view the results of the survey.

The standard SIS application will generate full documentation of the survey results, and provide output for survey statistics, contour charts, illuminated plots etc. For some purposes this may be sufficient, but normally additional SIS post-processing packages available are used for data cleaning, image processing and final chart production.

Parameter settings

There are a number of parameters that must be set. These are:

- Installation parameters for setting up e.g. communication, information related to the physical installation of the sensors and calibration results
- Runtime parameters for setting e.g. the operational modes of the multibeam echo sounder, sound speed profiles and data cleaning
- Survey parameters for setting e.g. projection, background data and administration of the survey data

Some parameters need starting values depending on type of operation and water depth.

You may start SIS by loading a predefined set of parameters, stored in a database, and then modify some of the individual parameters observing the effect on the displayed data. The modified parameters, including all the remaining parameters, can then be stored as a user specified set-up.

All parameters, as well as all the survey information, are stored in a database. The raw data is stored to disk.

You may wish to optimize system performance by adjusting parameters in the system. When the results are as desired, the current parameters set may be stored in the database for later retrieval.

Survey handling

Every echo sounder logs data to a survey. If no survey is defined, data will be logged to a predefined “fallback” survey.

Note

We strongly advise you to define your own default surveys. A default survey contains information about where to store the raw and processed data on the disks, what projection to use, coastlines to display etc.

When you create a new survey, you can use a default survey as a template for the new survey. This may save a lot of parameter definitions, and make life a lot easier for the surveyor.

More information

- *Operational procedures* on page 108
- *Parameter references* on page 209

SIS as a controller

This manual also describes the use of SIS as an interface between Kongsberg Maritime’s multibeam echo sounders and third party data acquisition software packages. The two third party software packages that has been tested and verified by Kongsberg are at this moment HYPACK ® and QINSy ®. When SIS is working as a controller, the full SIS functionality is not needed.

An unlicensed version of SIS will work as a controller. The purpose of this is as follows:

- Provide installation parameters needed by the Processing Unit in real time
- Provide runtime parameters (ping rate, coverage etc.)
- Operation and activation of the echo sounder
- Export of echo sounder datagrams to the third party software package
- Data logging in Kongsberg format

The data logging mentioned above is only provided for testing and debug in case of equipment problems.

In the case of using SIS as a controller all installation settings have to be set correctly inside the controller. In addition, position, heading and attitude must be interfaced to the processing unit.

When SIS operates as a controller, the following will not be a part of the controller and have to be handled by the third party software:

- Installation parameters to calculate the correct depths (not needed by the sounder in real-time)
- Calibration
- Quality control of the data
- Data logging for daily operation
- Data cleaning and post-processing
- Creation of digital terrain models (DTM), charts, printouts etc.

The installation values needed in the controller will only be the one needed by the echo sounder itself to export quality data to third party software. Example: If the echo sounder is roll stabilized, it needs roll data, correct installation angles for motion sensor and sonar head.

HYPACK®

The Hypack software package will treat the echo sounder as a separate sensor and provide the drivers for interfacing. The motion data needed for correction of the echo sounder data is read from the network (provided by the sounder) together with the range data. The position is interfaced and logged by Hypack in a standard way (read from serial line).

Note

The motion data provided by the echo sounder is moved from it's initial position to the location of the echo sounder. This is done inside the echo sounder Processing Unit.

QINSy ®

Qinsy read the echo sounder range datagrams from the network and all other sensors are interfaced by Qinsy directly. In other words, position and attitude data is interfaced to a serial line directly on the Qinsy PC. To provide correct timing of depths and attitude data the Qinsy PC and the Processing Unit need to be synchronized. This is done by connecting a 1PPS cable from the position system to the echo sounder Processing Unit as well as to the Qinsy PC itself. In addition ZDA clock datagrams has to be provided to the two units. If the echo sounder is roll stabilized then roll data has to be sent to the Processing Unit.

Note

For detailed information on the setup of software from Hypack or Qinsy, refer to the manufacturer's documentation.

Note

Data logged in the Kongsberg format has been time tagged in the Processing Unit of the echo sounder. This means that the time tagging is accurate and reliable. If other logging systems are used, the time tagging of the data is the responsibility of that logging software if they bypass these files.

Graphical user interface

This section contains description of the graphical user interfaces and the parameters related to setting up the appearance of SIS.

Topics

- *The application window* on page 25
- *SIS frames* on page 27
- *Toolbars* on page 33
- *View menu* on page 38
- *Keyboard and mouse operations* on page 43
- *Hotkeys* on page 46
- *File storage locations used by SIS* on page 47
- *Common display buttons* on page 48

The application window

All interactions with SIS take place via a windows based interface on the Operator Station.

When you launch SIS, the application window opens containing several frames that can be set up. Available options will depend on what instrument you are using.

The SIS application window appears below. A description of its parts follows.

Figure 2 The SIS application window

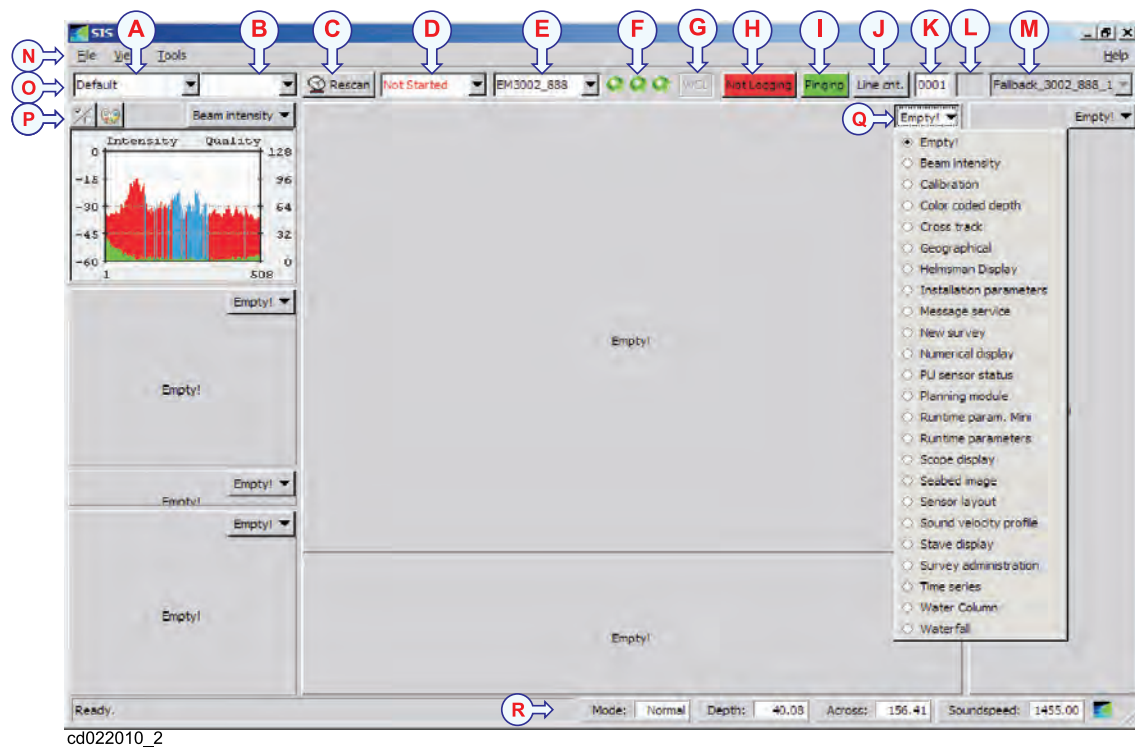

Description of the SIS application window

- A Frame settings
- B Active grid
- C Rescan button
- D Sonar systems detected, but not started.
- E Current sonar system
- F Status lamps for current sonar system
- G Water Column Logging (WCL) status button
- H Raw data logging status
- I Pinging status
- J Line counter
- K Line number
- L Time to line shift
- M Current survey name
- N Main menu
- O Main toolbar
- P Frame toolbar
- Q Available frames
- R Status bar

SIS defines a screen layout with up to seven simultaneous display windows (or frames). The boundaries between the frames can be shifted so that the frame sizes are adjusted to the user needs, but the system will make sure that no display frame is ever hidden behind another one. The information contents of each display frame can be changed according to the needs.

SIS has many windows, but there are always seven frames. You can choose from a list of windows for each frame, and you can save and read your own set up.

The frames are designed so that they will never overlap. This makes it impossible to hide one window behind another. You can change the size of the frames by moving the slide-bars. The four frames on the left are separated by three slide-bars which can be moved up and down, and the two frames in the middle are also separated with a slide-bar. There is also a slide-bar to the left of the four frames, and there is a slide-bar at the frame to the right.

The menu bar at the top contains common actions such as save/read settings, exit etc.

The next menu bar contains basic controls for all echo sounders. There are drop-down lists for surveys and survey settings, and for detected echo sounders and the echo sounder currently being operated. There are also control buttons to rescan for echo sounders, start/stop logging or pinging and line counting. Status lamps indicates hardware status for multibeam echo sounders.

In addition to the seven frames in the SIS main layout, up to five additional SIS frame can be opened in separate “tear-off” windows. See *Tear-off windows* on page 39 for details

SIS frames

The various windows available in SIS are:

- Beam intensity
- Calibration
- Colour coded depth
- Cross track
- Geographical
- Helmsman Display
- Installation parameters
- Message service
- New survey
- Numerical display
- Planning module
- PU sensor status
- Runtime parameters
- Runtime Parameters Mini

- Scope display
- Seabed image
- Sensor Layout
- Sound velocity profile
- Stave display
- Survey administration
- Time series
- Waterfall
- Water column
- Empty frame

Each frame is briefly explained in the following. For detailed description of each of the available frames, please see

- *Windows and views* on page 55
- *Frame toolbars parameters* on page 209

Figure 3 Example of SIS frame setup

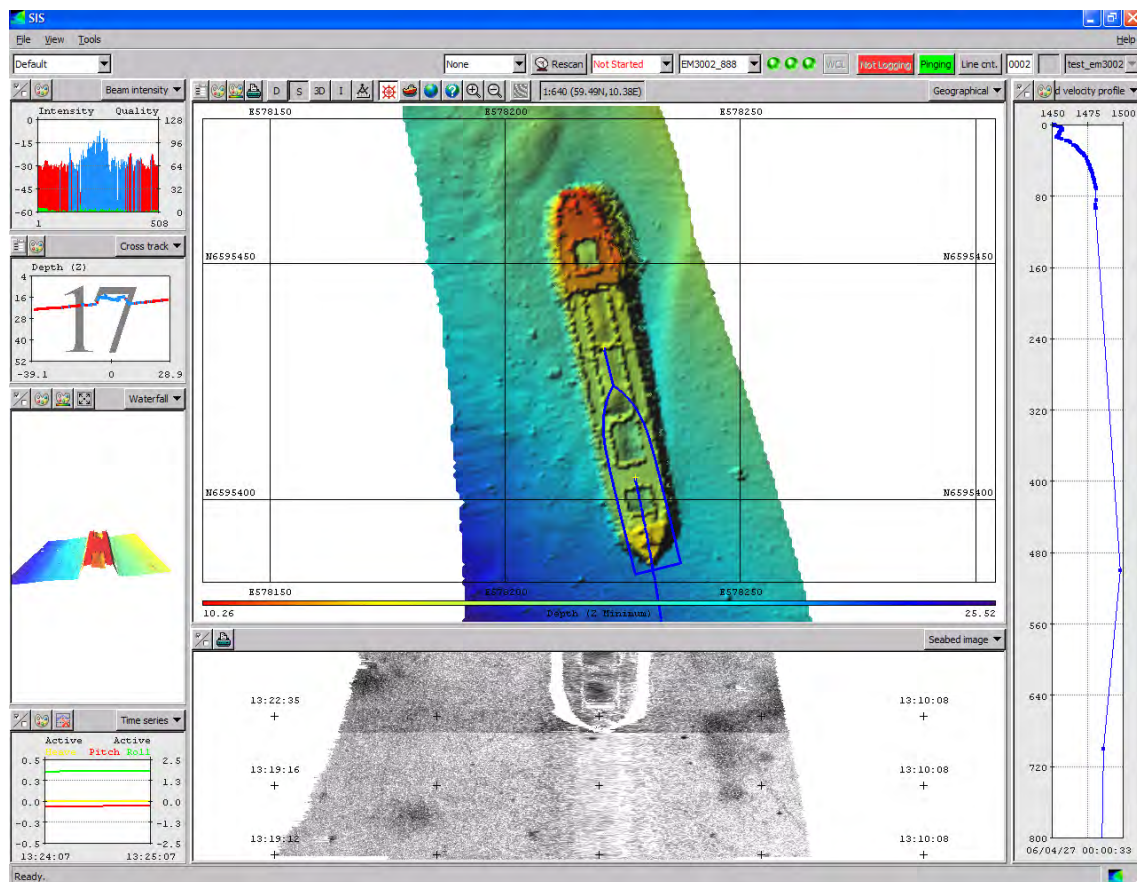

Geographical

The **Geographical** window is used to display all geographical data such as:

- DXF files
- Terrain models generated from ASCII xyz files
- Terrain models from surveys
- Geographical net (geographic and projection net)
- Other kinds of background data from ASCII-files
- Depth difference in each grid cell
- Number of points inside each grid cell
- Display of seabed imagery data generated by the GridEngine
- C-MAP background maps

It is possible to display several terrain models at the same time, both the terrain model that is being generated by the current survey and terrain models generated from previous surveys. If the data is in ASCII xyz-files, a terrain model can be generated and displayed as background data.

The **Geographical** window uses OpenGL for smooth rendering. This means that all views are 3D enabled and can be rotated in any direction.

SIS uses projection coordinates to display the data. The projection is set from the **New survey** or **Survey administration** frames. You can define your own projection or choose from a wide range of predefined projections. A 7-parameter datum transformation is also available.

The **Geographical** window can display a lot of different information. You can select from a long list of features what to display.

Note that the terrain model can be displayed with various depth values:

- Z – the distance from the surface to the seafloor
- Zt – tide corrected depth using a tide file
- Zv – tide corrected depth based on GPS observations and a geoid model
- Zg – the distance from the sea floor to the geoid
- Zr – the distance from the sea floor to the ellipsoid

For each grid cell you can choose if you want to see the minimum, median or maximum depth.

Note

SIS calculates the median depth, not the mean depth for each cell. The mean depth is an artificial depth which has not been observed, whilst the median is a real, quality controlled observed depth.

Beam intensity

The **Beam intensity** window shows the signal strength for each beam. Blue means amplitude detection and red is phase detection. Green indicates the quality for each measurement.

Cross track

The **Cross track** window shows the depth from each beam. The x-axis can either be meters or beams. Blue is amplitude detection and red is phase detection.

Seabed image

The **Seabed image** window logs seabed image data. The resolution in across direction depends upon the size of the window, the width of the swath and the resolution of the sonar. In the across direction a grid will be created to give the highest possible resolution in the window, and then each and every ping is stacked on top of each other.

Numerical display

The **Numerical display** window shows a list of current value of 36 different parameters. The parameters to show can be selected from a comprehensive list of available parameters.

Some of the parameters will give indication if the value exceed given limits by changing the background to yellow (warning) or red (error). This makes it possible to easily discover if there is a problem with some parts of the equipment. All exceptions are logged by **Message service**.

Message service

All messages from SIS are stored in the SIS database, SISDB. You can open the **Message service** window to see all messages that have been generated, and when they arrived. It is possible to mask certain types of messages and write these to a file. You can also choose a time frame to display the messages from.

Helmsman Display

The **Helmsman Display** window is usually used together with the **Planning module**.

When you have selected a planned line for surveying, the Helmsman Display window will show guidance information to the helmsman, such as position, depth, speed, course, cross track distance from planned line (XTE), etc.

There is also a history of XTE and a graphic presentation of the XTE and you can choose which of these parameters to display.

Colour coded depth

The **Colour coded depth** window shows the depth from each beam. The y-axis is always time and the x-axis is always beam number.

New survey

In the **New survey** window parameters defining a new surveys are created, including survey name, projection, background data, storage location, etc.

Survey administration

In the **Survey administration** window you can define survey parameters, such as projection, background data to display and where to store the survey data on disk. Normally, the default set-up can be used.

Planning module

The Geographical window can be set in Planning mode. From the **Planning module** survey lines can be created, survey areas can be defined and filled with parallel lines etc. You can save the planned lines to a planned job, and read a planned job from disk.

Time series

The **Time series** window is used to display different kinds of time series. Normally heave, roll and pitch from the active sensor is displayed. The following can also be displayed:

- Depths and backscatter from four beams selected by the user
- Depth below the water surface for the most vertical beam
- Depth and backscatter of the centre beam
- Single beam and multibeam depths for comparison
- Height
- Heave, roll and pitch from active and/or inactive motion sensor

Waterfall

The **Waterfall** window is fully implemented with 3D capabilities. You can zoom, pan and rotate freely in 3D, and the z-axis can be exaggerated to see small objects better.

Water column

The **Water column** window shows a graphical representation of the beam formed data for the entire water column for each beam. This window is only available for echo sounders with water column capabilities.

Sound velocity profile

SIS uses the depths generated in the Processing Unit. This means that the depths have already been corrected for sound speed profile. The current sound speed profile used by the Processing Unit is shown in the **Sound velocity profile** window.

Scope display

The **Scope display** window can be used to investigate the receiver echo data. It is mainly used for test purposes. The data is not logged. This window is available for multibeam echo sounders.

Stave display

The **Stave display** window shows a graphical representation of the signal level of all of the receiver elements (i.e. staves). This can be helpful for debug and for performance checks (display of interference signals, air bubbles, saturation, etc.) The data is not logged. This window is available for multibeam echo sounders with stave display capabilities.

Installation parameters

The **Installation parameters** window is used to set fixed installation parameters, including communication parameters to external sensors, installation offset angles and locations, calibration results, etc. These parameters are normally set only once. The parameters can not be modified during operation.

Built In Self Tests (BIST) are run from here.

Runtime parameters

The **Runtime parameter** window contains parameters that can be changed during operation, including mode of operation, sound speed profile and filter settings.

In addition you may set the parameters employed by the Real Time Data Cleaning module.

Calibration

In the **Calibration** window you will be presented to a cross-section of the data from the selected survey lines. The Geographical window must be set in calibration mode (C), the survey lines to use (at least two) for the calibration must be selected and a corridor along or across these survey lines must be defined. Then the pitch, roll, heading and time offsets can be altered to visually see the impact on the data in the defined corridor.

When new offsets are obtained these must be entered into the installation parameters.

PU sensor status

Note

*The **PU – Processing Unit** may be a separate hardware unit or an integrated part of the **TRU – Transceiver Unit** cabinet, depending on echo sounder system.*

For SIS it makes no difference whether the communication is with a PU or a PU inside a TRU. The term PU is used in this manual.

The **PU sensor status** window shows how the PU's input sensors are set up. If any signal is missing, this is indicated by changed colour.

Runtime parameters Mini

The **Runtime parameters Mini** window is a subset of the Runtime parameters menu with the most commonly altered parameters in a small window.

Sensor layout

The **Sensor layout** window, display all defined sensors position in a 3D display. This window will give you an indication if the installation parameters are entered incorrectly.

Related topics

- *Tear-off windows* on page 39
- *Windows and views* on page 55

Parameter references

- *Frame toolbars parameters* on page 209

Toolbars

SIS has two types of toolbars. The **Main toolbar** is common for all frames. Each frame also has its own individual toolbar.

Main toolbar

The **Main toolbar** is located just below the **Main menu**. It contains several buttons and combo boxes.

Figure 4 Main toolbar

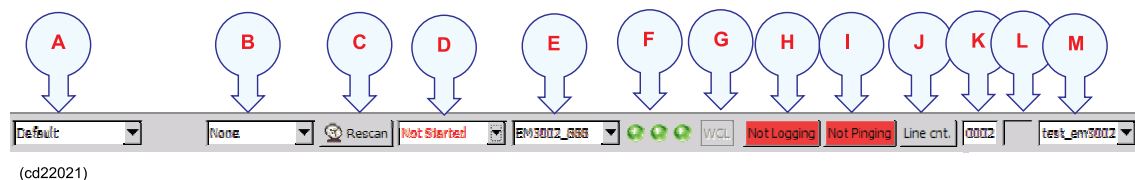

- (cd22021)
- A Settings:** You can select different display settings from this combo box. Choose between standard settings or create your own by selecting **Save Settings As...** in the **File** menu.
 - B Active survey:** Select the active survey. All surveys are listed, both the surveys you log on and the ones imported. You can only calibrate the active survey.
 - C Rescan:** Press the **Rescan** button, and the program will scan for available echo sounders on the network. If for some reason contact with the echo sounder is lost, it is not necessary to shut down and restart SIS.
 - D Echo sounders - not started:** This combo box displays all the echo sounders SIS has detected on the network at start-up time or when doing a rescan. All multibeam echo sounders announce themselves on the network when they are active, and SIS will detect them automatically. Select the echo sounder you want to start from this list.
 - E Current echo sounder:** This combo box displays which echo sounder is currently being operated. You must choose one at the time when setting the installation and runtime parameters for the echo sounder. Select the echo sounder you want to change parameters for from this list.

F Status lamps: These lamps are for multibeam echo sounders only and applies to current echo sounder.

- **Lamp 1:** PU/TRU status (Processing Unit/Transceiver Unit)
- **Lamp 2:** BSP status (Beamforming and Signal Processing)
- **Lamp 3:** SH status (Sonar Head)

While logging, the lamps will be continuously updated.

Green	Orange	Red	Grey
OK	Warning	Error	Connected hardware is not in use

Tip

The 8 last echo sounder originated warning/error messages are displayed as tool tip when cursor is hovering above the PU, BSP and SH status buttons. The list is only displayed when they indicate warning or error conditions in the echo sounder (yellow and red lamps respectively). The messages are numbered with the newest on top.

G WCL: The **WCL** button is used for controlling the water column logging as well as showing the current water column log status.

By pressing the **WCL** button the water column logging operation is enabled or disabled. Water column logging is enabled when the button is in the down position. The actual water column logging is controlled by the standard **Logging** button. The **WCL** button turns green when the logging is active and red when logging is enabled, but suspended (i.e. off).

The **WCL** button is always displayed, but is only active for echo sounders with water column capabilities.

H Pinging: Press this button to start and stop pinging. Start pinging to activate the echo sounder (i.e. sending sound into the water). The colour of the button is green while pinging and red when pinging is off.

The text in the button reflects the current status.

I Logging: Press this button to start and stop logging. Start logging to write data to disk. The colour of the button is green while logging and red when logging is off.

The text in the button reflects the current status.

Note

If pinging is Off when logging is turned On, pinging will automatically be turned On. If logging is On and pinging is turned Off logging will automatically be turned Off.

J The **Line cnt** button is used to create a new line without stopping the logging and then starting it again. The line count is incremented by one when button is pressed.

K Line counter: The text field displays the line count for the currently selected echo sounder. The line count is cyclic between 1 and 9999. It is possible to enter a line number manually.

If logging is *Off* the line count is for the next line started. If logging is *On* the count is for the current line.

- L Remaining time:** This field shows the remaining time to log in the current line, i.e. the time before a new line is started. The time unit is in minutes. (When 1 minute is displayed this indicates less than 1 minute logging remaining.)
- M Current survey:** This combo box displays the current survey name. You can select all surveys for the current echo sounder from this combo box. When selecting another survey, SIS will change to that survey and start logging to that survey when this is enabled.

This combo box is disabled when SIS is logging.

Related topics

- *Frame toolbars* on page 35
- *Echo sounder – Not started list* on page 35
- *Current echo sounder* on page 36
- *Line counter toolbar set* on page 37

Frame toolbars

All frames have their own toolbar. On these toolbars there can be several buttons or just the Frames button. The most frequent buttons are:

- A Show/hide:** Press this button to open the **Show/hide** dialogue box.
- B Annotation colours:** Press this button to open the **Annotation colours** dialogue box.
- C Dynamic colours:** Press this button to open the **Dynamic colours** dialogue box. The dialogue box will only be launched if at least one or more surveys are loaded.
- D Frame selection button:** Press this button to select the content you want in that specific window frame.

Figure 5 Example of a frame toolbar



The most common buttons are described in *Common display buttons* on page 48.

Special buttons for each frame are described in *Windows and views* on page 55

Echo sounder – Not started list

The **Not started** list will be displayed in a combo box found in the main toolbar.

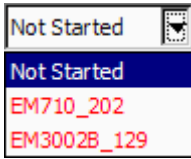

The list contains all non-started echo sounders detected by SIS on the network. The list is linked to the autostart mechanism.

The combo box will only be displayed in two cases:

- 1 When echo sounders are detected by the system for the first time.
- 2 When the detected echo sounders differs from the set of echo sounders started in the previous SIS session. That is, if echo sounders have been added or removed from the network, and the autostart mechanism therefore is not activated.

In any other circumstance the autostart mechanism will start the echo sounders automatically and the combo box will be empty and not visible.

Note

*The Autostart of the echo sounder can be disabled/enabled under **Display found** by selecting **Tools**→**Custom...**→**Set parameters**.*

When you select an echo sounder from the list, you start the echo sounder and it will disappear from the list.

If automatic self test at startup is selected the **BIST** page will be displayed in a tear off window and the **Run all BISTs** sequence will be automatically started. This sequence can be cancelled at any stage by pressing the **Quit** button in the pop-up window that is displayed. When cancelling, the current test must run to completion before the sequence halts.

Note

If for any reason an echo sounder fails during start (BIST, Built-In Self Test, 99 failure) the echo sounder will remain in the list and the combo box will still be visible. The reason for this is to allow you to correct the problem and try a rescan.

If the licensing allows for only one started echo sounder, the combo box will be removed as soon as the start has been performed with a positive result.

If the licensing allows for several started echo sounders, the combo box will be removed only when the list is empty, i.e. when all echo sounders has been started.

Related operational procedures

- *How to start pinging* on page 160
- *How to start the echo sounder* on page 154

Parameter references

- *Display* on page 339

Current echo sounder

Current echo sounder gives you a list of the all echo sounders and other instruments that are connected to the SIS software. Only the current echo sounder is visible in the text field. Press the arrow to see the entire list or click in the text field.

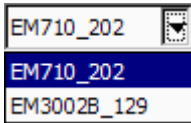

Select an echo sounder from the list. This echo sounder is now available for configuration. Each echo sounder is identified by name and serial number and all displayed frames will be updated to show the information from this unit, if applicable. Only one echo sounder can be selected as current at any given instance, i.e. you can configure only one echo sounder at a time and you can see data (for example beam intensity, cross track, numerical data, etc.) only from this current unit.

Related operational procedures

- *How to start pinging* on page 160
- *How to start the echo sounder* on page 154
- *How to interface a singlebeam echo sounder in SIS* on page 156
- *How to start and stop logging – Alternative 1* on page 169
- *How to start and stop logging – Alternative 2* on page 169
- *How to save data* on page 169

If you want to add instruments without a PU (Processing Unit/Rack) to the list, use the **External sensors** and **Instrument combinations** found on the **Tools** menu.

If you want to remove instruments without a PU (Processing Unit/Rack) from the list, use the **Remove instruments** found on the **Tools** menu.

Parameter references

- *External sensors* on page 371
- *Instrument combinations* on page 377
- *Remove instruments* on page 378

Line counter toolbar set

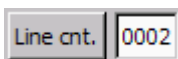

The **Line counter** button and **Line counter** text field are found in the toolbar.

The Line counter text field displays the line number for the currently selected echo sounder. The count is cyclic between 1 and 9999.

When the **Line counter** is pressed, the line count is incremented by one for all active, logging echo sounders and not only for current echo sounder.

Note

If current echo sounder is not logging, nothing happens when the line counter button is pressed.

The line count for an echo sounder can also be incremented by three other mechanisms in addition to using the line counter button:

- 1 The line count is incremented each time logging stops showing the next line to be logged. Only the count for the handled (current) echo sounder is affected.

- 2 To avoid very large log files (.all-files) the counter for all active echo sounders are incremented automatically every 30 minutes. This can be configured from the Main menu; **Tools**→**Custom...**→**Set parameters**. This, however, only happens when the counter has not been incremented by other means within the last 30 minutes, i.e. by pressing the line counter button or by stopping and starting logging.
- 3 The line counter may be manually edited, when not logging. The edited value is for the next logged line.

Note

If several echo sounders are used and the line count initially is the same for all, it's important to notice that the counts may deviate after a while. This is due to the above described behaviour.

Related operational procedures

- *How to start the echo sounder* on page 154
- *How to start and stop logging – Alternative 1* on page 169
- *How to start and stop logging – Alternative 2* on page 169
- *How to save data* on page 169

View menu

The **View** drop-down menu gives you the following choices:

- *Tear-off windows* on page 39
- *Icons* on page 40
- *C-MAP detail level* on page 41
- *Colour palette* on page 41
- *Status bar* on page 42

Tear-off windows

Tear-off windows are accessed from the **View** menu.

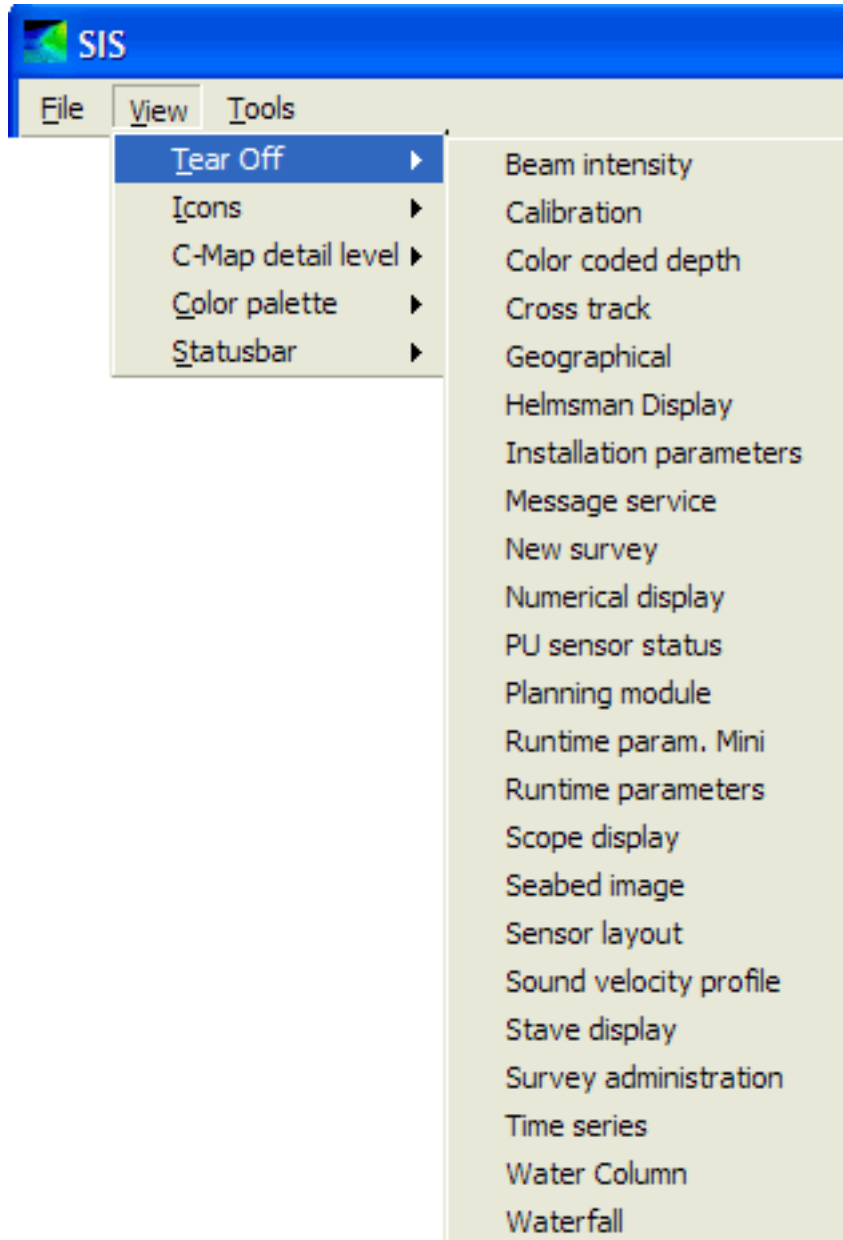

It is possible to open any additional SIS frame in separate "tear-off" windows by selecting it from the **View**→**Tear Off** menu.

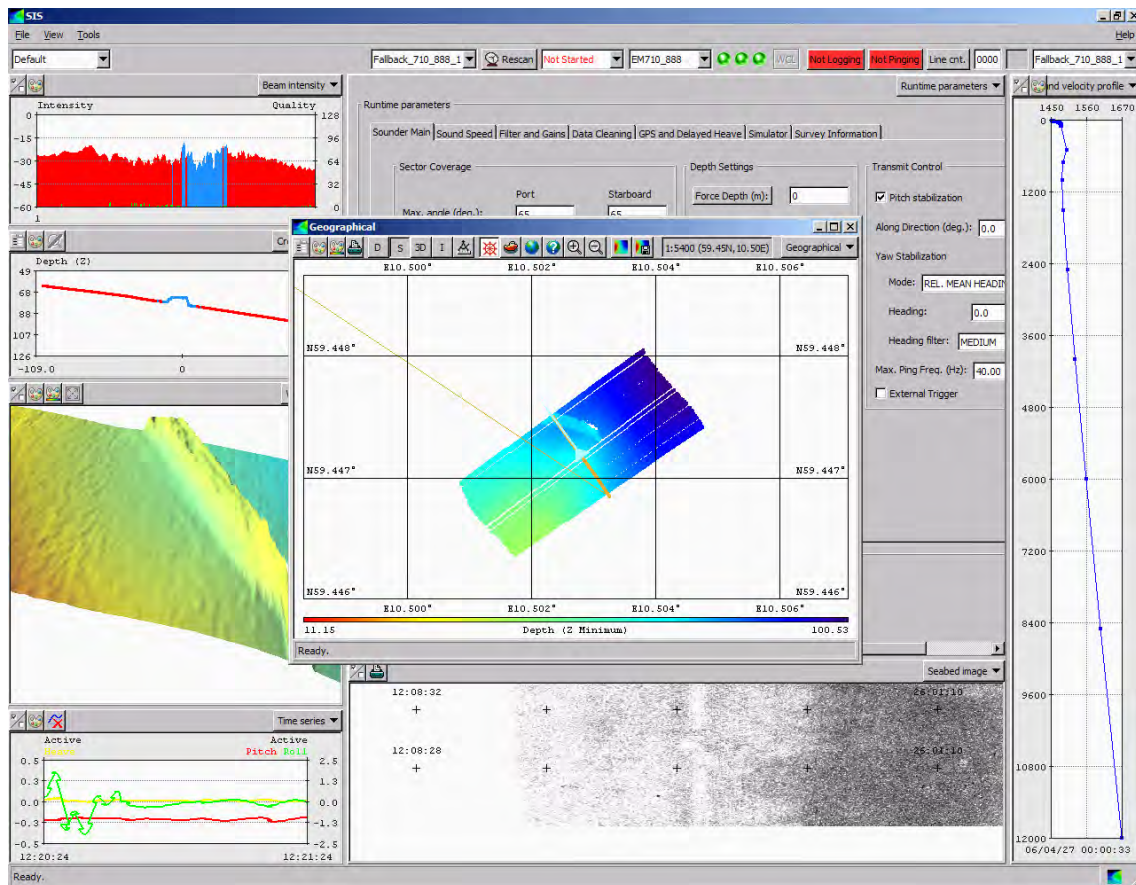

If the selected frame is already open in another window, the frame will be moved to the new tear-off window, and the other window will be emptied.

It is possible to have multiple tear-off windows open at the same time, a maximum of five tear-off windows are allowed. However, it is important to note that each open frame requires some processing power, so you may overload the system by opening too many windows at the same time. It is recommended to monitor the CPU load. If the CPU load remains near 100% for any length of time, you may have to close one or more of the tear-off windows. Frames with high CPU load include the Geographical, Water Column, Stave Display, Seabed Image and (to a lesser degree) the Waterfall frame.

Note

Parameters for size, location, and frame settings of the tear-off windows are not saved when settings are saved (File->Save Settings).

Screen capture of the tear-off windows are not stored by pressing Ctrl-S. Only the SIS mainframe is captured by Ctrl-S.

Icons

The **Icons** menu is accessed from the **View** drop-down menu.

Choose between:

- **Small Icons:** This will make all the frame toolbar buttons smaller
- **Large Icons:** This will make all the frame toolbar buttons larger

C-MAP detail level

Note

This menu option will only be available if C-MAP is installed.

The **C-MAP detail level** is accessed from the **View** menu.

To specify the detail level of the C-MAP background, choose between the following display levels with increasing levels of details:

- Basic
- Standard
- Full

Related topics

- *C-MAP – Licence administration* on page 379
- *Geographical – C-MAP manipulation mode* on page 225
- *C-MAP CM-93/3* on page 443

Colour palette

The **Colour palette** is accessed from the **View** menu.

Depending on light conditions where the SIS display is located the colours of may be changed to best adapt to the conditions.

Choose between the following colour palettes:

- **Day:** Bright day
- **Day Blackback:** Day with black background
- **Day Whiteback:** Day with white background
- **Dusk:** Dusk – less brightness to adapt to night vision
- **Night:** Night – lesser brightness to adapt to night vision

Windows PaletteController

Each of above palettes use a colour scheme of 64 colours with different RGB value for each palette. If used together with **PaletteController**, all Windows colours can be set as well.

PaletteController is an additional SIS program found in the installation's **bin** directory. **PaletteController** can be used to set the Windows colours globally on your computer according to the colour palettes defined by SIS.

For **PaletteController** to take effect you must ensure that the **Windows Display Properties**→**Appearance** is set to **Windows Classic style** for Windows XP and to **Windows Choice** for other Windows platforms.

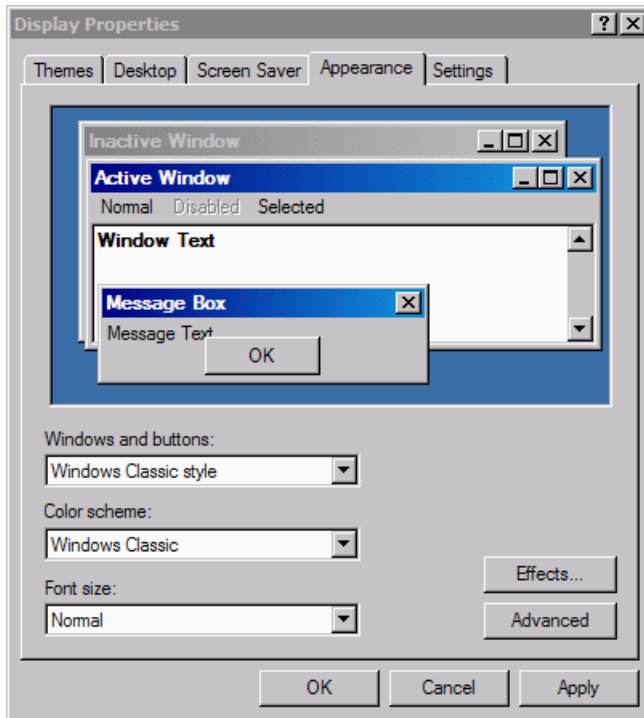

Status bar

The **Status bar** is accessed from the **View** menu.

By selecting **Status bar** from the view menu you will be given the choice to display current value of four essential transducer parameters in a status bar at the bottom of the SIS display. By ticking the check box for each parameter, current parameter value will be continuously updated in the Status bar. Press the OK button to confirm the selection and leave the menu.

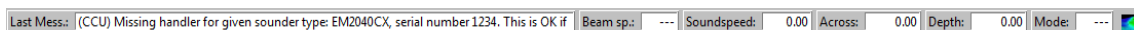

The following parameters can be displayed:

- **Mode:** current ping mode
- **Depth:** current depth
- **Across:** swath width in metres on the bottom
- **Soundspeed:** Sound speed at transducer depth
- **Last mess.:** The last message (error, warning or information message) generated by the system.

Tip

Hovering with the cursor above the **Last message** field will display the last 3 messages as a tool tip. The messages are numbered with the newest on top.

- **Beam sp.:** Beam spacing

Keyboard and mouse operations

In SIS there are different combinations of mouse and keyboard operations used to change the view or give quick access to selected functions. The combination of mouse and keyboard operation varies slightly depending on the frame you are working in. The keyboard and mouse operations for panning, rotating and zooming for each frame these functions applies to are presented in this section.

Topics

- *Keyboard and mouse in the Geographical view* on page 44
- *Keyboard and mouse in the Planning module view* on page 44
- *Keyboard and mouse in the Sound velocity profile view* on page 45
- *Keyboard and mouse in the Waterfall view* on page 45
- *Keyboard and mouse in the Sensor layout view* on page 45
- *Keyboard and mouse in the Water column view* on page 46
- *Keyboard and mouse in the Calibration view* on page 46

Rotate operations

To understand how to rotate the grid, it may be helpful to visualize a “virtual trackball” in the centre of the view. To rotate the grid, click and drag the mouse as if you were trying to rotate this “virtual trackball”. For example, if you click the mouse in the centre of the view (i.e. the centre of the virtual trackball) and drag straight up or down, the virtual trackball will rotate about it’s horizontal axis (i.e. the x-axis). This results in the grid rotating purely about the x-axis.

If you click the mouse in the centre of the view and drag straight to the left or right, the virtual trackball will rotate about it’s vertical axis (i.e. the y-axis). This results in the grid rotating purely about the y-axis.

If you click the mouse at the edge of the view, and then drag the mouse, the virtual trackball will rotate about an axis perpendicular to the plane of the view (i.e. the z-axis). This results in the grid rotating purely about the z-axis.

Keyboard and mouse in the Geographical view

Operation	Keyboard and mouse operation
Zoom to region	Left mouse button Press left mouse button, drag the mouse to a new area and release the mouse button.
Pan	Right mouse button Right click in the grid, hold down and move the view.
Zoom	Scroll the mouse wheel To zoom in or out on the geographical view, scroll the wheel forward to zoom in, or backward to zoom out.
Rotate	Shift key + Right mouse button To rotate the grid, hold down the Shift key, right click and drag the mouse.
Display high res. seabed image	Left mouse button + Shift key Mark the area to display as seabed image by using left mouse button to mark first corner, then press the Shift key, then drag the mouse to desired end corner. Release buttons.

Note

3D must be enabled to rotate the geographical grid.

Keyboard and mouse in the Planning module view

Use the Ctrl key and the mouse to carry out any editing or manipulation of planned lines.

Operation	Keyboard and mouse operation
Accept or Cancel	Ctrl + Right mouse button Use the Ctrl key while clicking the right mouse button to open the Confirm changes dialogue. Use left mouse button to accept or cancel as required.
Select a line or a polygon	Ctrl + Left mouse button Selecting a line or a polygon is carried out by holding the Ctrl key down while clicking on the object to be selected. Objects already selected will be deselected.
Deselecting multiple objects	Ctrl + Right mouse button Deselecting multiple objects can be carried out by holding the Ctrl key down while clicking on the right mouse button. This will open the Selected objects dialogue, where you can choose to deselect all selected lines, polygons or both.

Keyboard and mouse in the Sound velocity profile view

Operation	Keyboard and mouse operation
Zoom to a region	Left mouse button Press left mouse button, drag the mouse to a new area and release the mouse button. Press the Zoom Reset Button to return the display to the original state.
Zoom	Ctrl key + Scroll the mouse wheel To zoom in or out on the view, hold the ctrl key while scrolling the wheel forward to zoom in, or backward to zoom out. Press the Zoom Reset Button to return the display to the original state.
Pan	Alt key + Scroll the mouse wheel To pan up or down along the profile, hold the Alt key while scrolling the wheel forward to pan down, or backward to pan up. Note that you can only use the pan functionality if you have zoomed the view.

Keyboard and mouse in the Waterfall view

Operation	Keyboard and mouse operation
Pan	Right mouse button To pan the waterfall grid, right click in the grid, hold down and move the view.
Zoom	Scroll the mouse wheel To zoom in or out on the waterfall view, scroll the wheel forward to zoom in, or backward to zoom out.
Rotate	Shift key + Right mouse button To rotate the grid, hold down the Shift key, right click and drag the mouse.

Keyboard and mouse in the Sensor layout view

Operation	Keyboard and mouse operation
Pan	Right mouse button To pan the waterfall grid, right click in the grid, hold down and move the view.
Zoom	Scroll the mouse wheel To zoom in or out on the waterfall view, scroll the wheel forward to zoom in, or backward to zoom out.
Rotate	Shift key + Right mouse button To rotate the grid, hold down the Shift key, right click and drag the mouse.

Keyboard and mouse in the Water column view

Operation	Keyboard and mouse operation
Force depth	Ctrl key + left mouse button Short-cut to force the bottom detection to selected depth.
Set scope beam number	Shift + left mouse button To view the beam pointed on by your mouse pointer in the scope display.
Rotate	Shift key + Right mouse button To rotate the grid, hold down the Shift key, right click and drag the mouse.

Note

*The **Force depth** and the **Scope beam** functions must have been enabled from the **Show/hide** menu of the **Water column** view before activation is possible.*

Keyboard and mouse in the Calibration view

In Calibration mode the Geographical window has the following additional keyboard and mouse functionality:

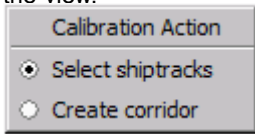
To	Operation
Select a line	Ctrl + Left mouse button To select a line, hold down the Ctrl key and left click on the line.
Open Calibration Action Quick Menu	Ctrl + Right mouse button To open the Calibration Action Quick Menu, hold down the Ctrl key, right click in the view. 
Select corridor	Ctrl + Left mouse button Set the end points of the corridor by holding the Ctrl key down while clicking left mouse button on each end point.

Hotkeys

The following functional hotkeys are defined in SIS

Key	Function
F2	Toggles logging on/off
F5	New line
F10	Toggle pinging on/off
F4	Toggle grid shading on/off

Key	Function
F8	Toggle depth under cursor on/off
Ctrl-S	Screendump of the application window saved as bmp file

You may redefine the hotkeys used for toggling logging and pinging on/off and for selecting new line. This is done from **Tools**→**Custom...**→**Set parameters**→**Logging**.

File storage locations used by SIS

During installation of SIS you will be prompted how to store your data. We strongly recommend using separate disk partitions for grid and raw data. The grid and raw data will be stored as follows:

- Raw data: <disk 1>:\sisdata\raw
- Grid data: <disk 2>:\sisdata\grids

The grid data disk will be used internally by SIS, and knowledge of the directory structure on this disk is not required.

The raw data disk contains raw data logged by SIS, i.e. the *.all files. The directory structure is by default \sisdata\raw\<survey_name>, and the filenames of the *.all files are defined during definition of your survey.

The raw data disk also contains the \common\ directory having a number of subfolders and use:

Table 1 The <disk 1>:\sisdata\common\ subfolders and their contents and use

Folder name	Contents/Use
3D_models	Default location for 3D models, i.e. AutoCAD (dwg), Inventor (iv) or VRML (wrl) files, to be imported into the geographical view.
ath	Default location for storing Applanix True Heave (ATH) raw data.
background	GeoTIFF files that are generated by pressing the Save background data button  are stored in this location.
backup_settings	Every time the OK button in the Installation parameters frame is pressed a backup file containing current PU parameters is generated. The backup file can be imported using File → Import PU parameters . The file name convention is Backup_<echo_sounder_name>_<serial_number>_<YearMonthDay>_<HourMinuteSecond>, e.g. Backup_EM_2040_888_20100428_123035.txt.
bist	Built-In Self Test results are saved to this location if the Save button on the BIST page is pressed.
compass_dev	This is the default location of any compass deviation files that you may want to use. Compass deviation files applies only if you are using SIS without any EM input, and are using a compass as your heading sensor. The compass deviation file is selected from the External sensor page.
Events	Location of events that are logged using the Global Event Marker.

Table 1 The <disk I>:\sisdata\common\ subfolders and their contents and use (cont'd.)

Folder name	Contents/Use
javad	Default location for storing Javad or Trimble GPS raw data.
KSGPL	Default location for storing *.ksgpl files to loaded as background to the geographical view.
maintenance	Default storage location used by SIS Data Logger
message\auto	The Message service automatically logs all system generated information, warnings and error messages and stores the files in this location.
planning	This is were the Planning module of SIS by defaults stores its files. The file location may be altered by the user using standard Windows Save as functionality.
printer_files	Default location for storage of the post script printer files that can be made from the Geographical view by pressing the Printer button.
projections	Default location for projection files to be imported into SIS
pu_param	Default location for storage of PU parameter files used by File→Import PU parameters and File→Export PU parameters .
screendumps	When pressing Ctrl-S a screen shot will be created and saved as a .bmp file in this location.
srh	Default location for storing Seapath Real Heave (SRH) raw data.
svp_abscoeff	This is where the default absorption coefficient files that SIS uses are located. When you want to load or save an absorption coefficient file from the Runtime parameters frame this is the default location for opening or saving the file.
svp_logger	Default location to log raw SVP data to be used in the SVP Logger utility program.
sys_settings	Contains the factory setting PU parameter files for all echo sounder system
terratec	Default location for storing RTCM raw data.
user_settings	Default location for storing the SIS display settings.

Common display buttons

Each SIS frame holds a toolbar with command buttons for parameter and display settings applicable to that frame.

The display buttons holds the same functionality independent of what frame it applies to. The common display buttons are described in this section.

Common display buttons

- *Annotation colours button* on page 49
- *Dynamic colours button* on page 50
- *Print button* on page 51
- *Zoom and view buttons* on page 51
- *Scale buttons* on page 53

Annotation colours button

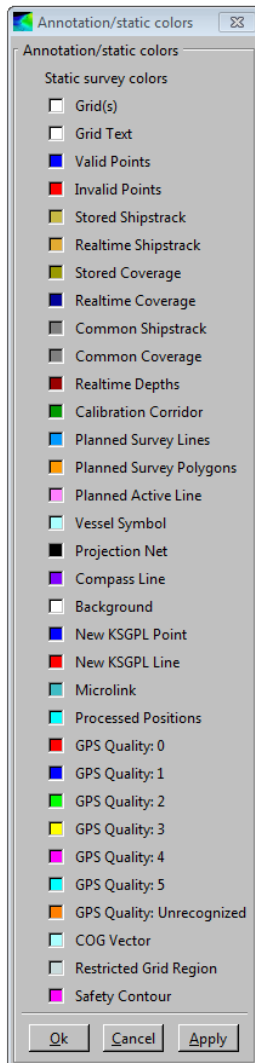

Display Colours: You can change the colours of the various elements displayed by double-clicking in the check box(es). The **Colour Dialog** window will appear. New colours can be selected in a number of different ways (using the eye dropper tool, entering the RGB colour code, using predefined colours etc.).

Select the new colour and click **Accept** to apply. **Cancel** if you do not want to change the colour.

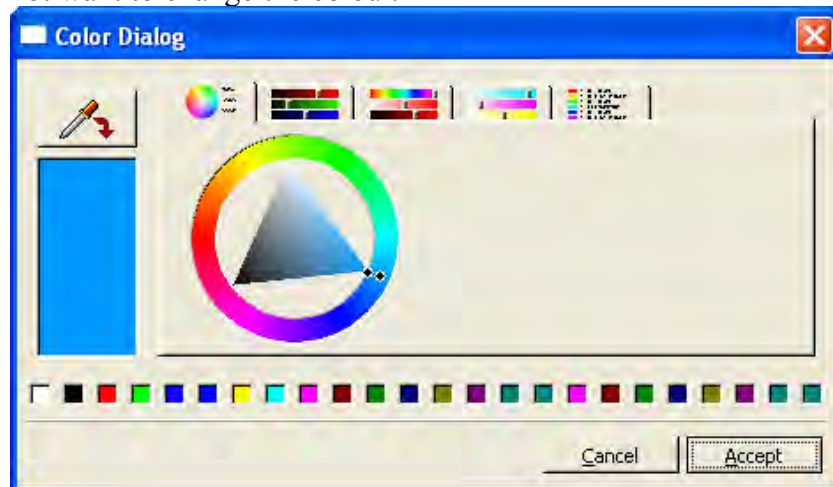

Dynamic colours button

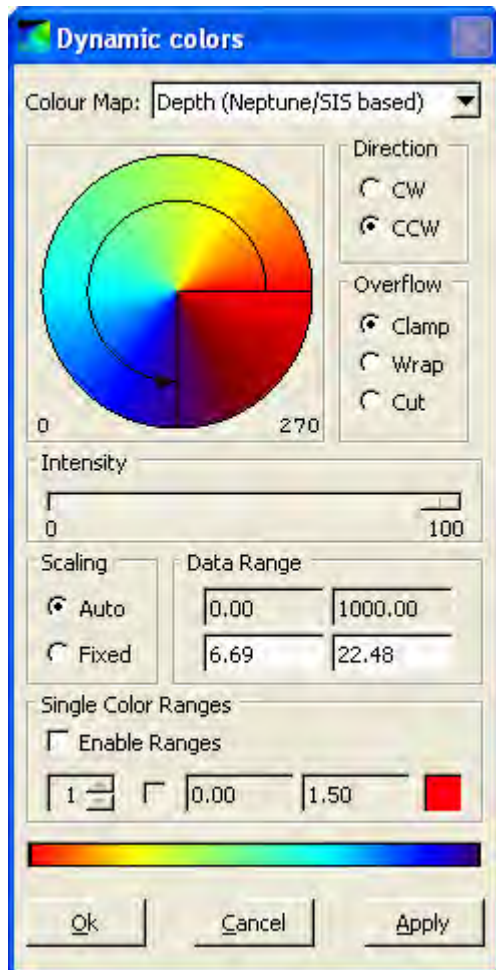

- **Colour map:** Select which objects to set the dynamic colours to.
- **Colour wheel:** Set the colour representation of the dynamic colours. Drag the arrow to set the start and stop limits.
- **Direction:** Set the direction of the arrow (CW or CCW).
- **Overflow:** Choose an overflow strategy for the colours – only valid when fixed scaling is selected.
 - Clamp - lock to the limits
 - Wrap - restart when reaching a limit
 - Cut - do not show data outside the limits
- **Intensity:** Set the intensity of the colours in the colour map. This can be used to dim the colour map for low light conditions.
- **Scaling:** Select automatic or fixed scaling.
- **Data Range:** Manually set the range (max/min) for the selected objects. The total range is automatically found from the data.
- **Single Colour Ranges:** Click in the **Enable** check box to set a range of data values to a single colour. For each set of depth ranges

a different colour can be chosen. Double-click in the right check box to open the **Colour Dialog** window.

Note

*The available settings varies slightly depending on what SIS frame the **Dynamic colour** button applies to.*

Print button



Press the **Print** button to print the view. The **Print Setup** dialog will open.

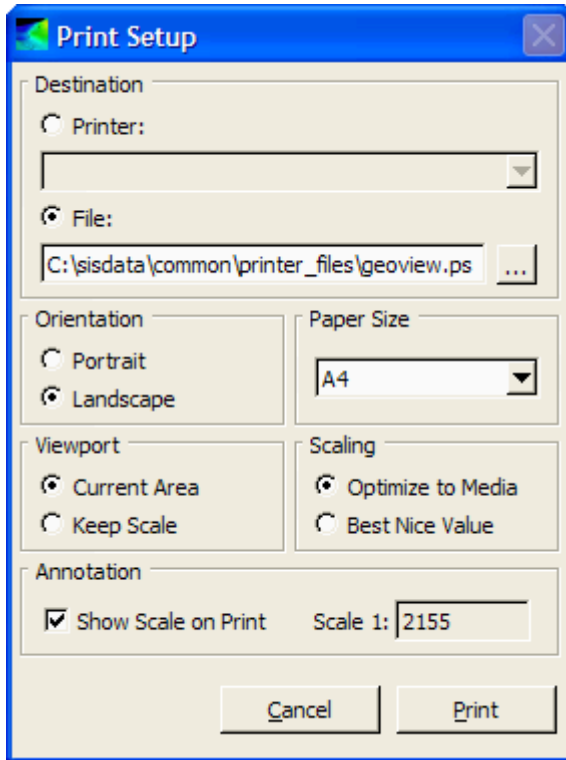

The following options are available:

- **Destination:** Select if you want to send the print to a postscript printer or to a file. Files are saved in postscript format (*.ps).
- **Orientation:** Select page orientation.
- **Paper Size:** Select paper size.
- **Viewport:** Select **Current Area** to print current view.

Select **Keep Scale** to send a larger area to the printer set by the **Zoom to region** dialogue. When selecting **Keep Scale** the centre of the view will correspond to the centre of the printout.

- **Scaling:** Select **Optimize to Media** to print view with it's actual scale. Select **Best Nice Value** to print the view with rounded scale values.
- **Annotation:** Show the scale on the

printout or not.

Note

Only postscript printers or plotters can be used.

Zoom and view buttons

Zoom functionality

- in
- out
- to given region
- by mouse
- to ship
- to world
- to active survey
- reset zoom
- reset view

- pause

Zoom in



When you press the **Zoom in** button, the magnification of the view will increase.

Zoom out



When you press the **Zoom out** button, the magnification of the view will decrease.

Zoom to given region



Any user-defined region can be zoomed up to fill the display view. To define the region, perform the following:

- 1 Press the **Zoom to given region** button.
A **Zoom to region** dialogue box will appear.
- 2 Fill in the desired scale and the centre coordinates.

Zoom to active survey



When you press the **Zoom to active survey** button, the **Geographical window** will zoom out to an area covering survey data for the active survey.

Zoom to world



When you press the **Zoom to world** button, the **Geographical window** will zoom out to an area covering all loaded survey data. Note that if the data areas are small and widely spread out the data may become invisible.

Zoom to ship



When you press the **Zoom to ship** button, the **Geographical window** will zoom to wherever the ship is located in the world. This button will be disabled if no vessel is present.

Zooming using the mouse

In addition to using the zoom buttons above you can also:

- Zoom in or out on the data by using the mouse wheel
- Zoom in on a specific region by pressing the left mouse button, drag the mouse to a new location and then release the mouse button

Zoom Reset button



Reset the display after a zoom operation. This button is only active if the display has been zoomed. Clicking on this button will reset the start and stop ranges and the start and stop range modes.

Reset View Button



Reset pan, zoom and rotation to default values.

Pause button



Pause or continue the display of data. While paused, the display is visible, but not updated.

Scale buttons

Scale functionality

- auto scale
- auto scale once
- fixed scale

Auto Scale button



Set the **Start Range Mode** and the **Stop Range Mode** of both the depth and across axes to Auto.

When the **Start Range** is set to **Auto**, the start range of each axis is automatically set to the minimum value in the data set each time data is received. When the **Stop Range** is set to **Auto**, the stop range of each axis is automatically set to the maximum value in the data set each time data is received.

This button provides a quick and convenient way to set both the start and stop ranges to Auto.

Pressing this button is equivalent to opening the **Show/Hide** dialogue and selecting **Start Range**→→**Auto** and **Stop Range**→→**Auto** for both the depth and across axes.

Auto Scale Once button



Set the **Start Range Mode** and the **Stop Range Mode** (of both the depth and across axes) based on the values of the current data set, then lock to this range setting for the remaining of the data.

The fixed start and stop range values in the **Show/Hide** dialogue will be updated with the new values. This is a quick and convenient way to change to Fixed range mode and simultaneously update the fixed start and stop ranges with values appropriate for the current water column data.

Note

Pressing this button will update the Fixed start range value and the Fixed stop range value in the Show/Hide dialogue.

Fixed Scale button



Set the **Start Range Mode** and the **Stop Range Mode** of both the depth and across axes to Fixed. The start and stop ranges will be set to the values that were last entered in the respective **Start/Stop Range** text boxes in the **Show/Hide** dialogue.

This button provides a quick and convenient way to set the start and stop ranges of both axes to **Fixed**.

Pressing this button is equivalent to opening the **Show/Hide** dialogue and selecting **Start Range**→→**Fixed** and **Stop Range**→→**Fixed**.

Note that this is not equivalent to clicking on the Auto Scale Once button because the Fixed Start/Stop Range values in the Show/Hide dialogue are not updated in this case.

Windows and views

This chapter describes the various **frames** in SIS.

Seven frames can be displayed at the same time. The content of each and every frame is defined by using the **Frame selection** button.

When the wanted frame configuration has been set up you may save the frame configuration for later retrieval. The frame configuration is saved from the main menu, **File**→**Save settings**.

Monitoring Windows

- *Geographical view* on page 57
- *Beam intensity view* on page 61
- *Colour coded depth view* on page 63
- *Cross track view* on page 64
- *Seabed image view* on page 66
- *Numerical display* on page 68
- *Message service view* on page 69
- *Helmsman display view* on page 70
- *Time series view* on page 72
- *Waterfall view* on page 73
- *Water column view* on page 75
- *Sound velocity profile view* on page 79
- *Scope display* on page 81
- *Stave display* on page 83
- *PU sensor status view* on page 86

Survey administration windows

- *New survey window* on page 89
- *Survey administration window* on page 91
- *Planning module window* on page 93

Parameter setup windows

- *Installation parameters window* on page 94

- *Runtime parameters window* on page 95
- *Runtime parameters mini view* on page 96
- *Sensor layout view* on page 98

Calibration window

- *Calibration view* on page 100

Geographical view

The **Geographical** window is accessed by selecting it from the **Frame selection** button or by opening it as a separate window from the **View→Tear Off** menu.

Purpose

The main purpose of the **Geographical** window is to show geographical data like surveys, shiptracks, coverage, planned lines and so on. The window consists of a geographical region with a toolbar on top. It can also be referred to as main window.

This window is valid for all instruments.

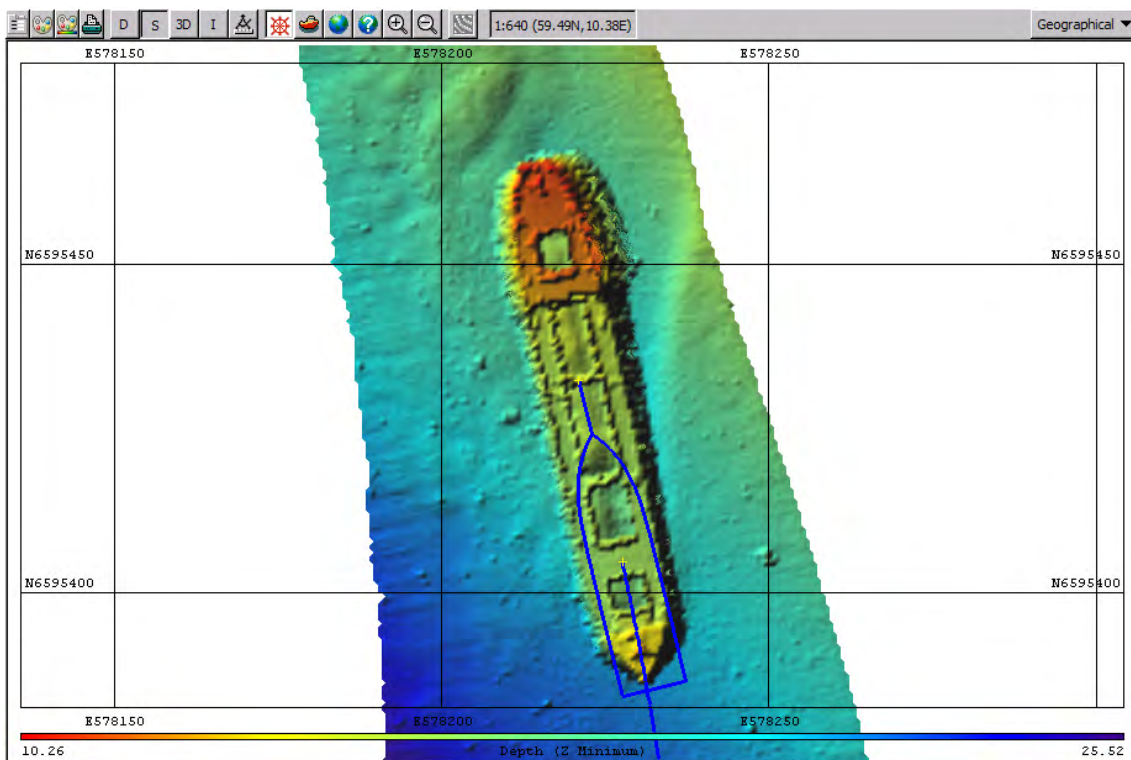



















Toolbar buttons

Figure 6 Toolbar example



The toolbar of the Geographical window holds the following buttons (from left to right):

Click this button	To
	Enter the geographical display options
	Set annotation colours
	Set dynamic colours

Click this button	To
	Print the view
	Show depth under cursor
	Toggle grid shading on/off
	Toggle between 2D or 3D
	Enter inspection mode
	Use the position and distance measure. Show position under cursor.
	Enter KSGPL edit mode (when selected)
	Enter planning edit mode (when selected)
	Enter calibration edit mode (when selected)
	Follow ship
	Zoom to ship
	Zoom to world
	Zoom to active survey
	Zoom to given region
	Zoom in
	Zoom out
	Load background data in .bgksgpl format
	Save background image in GeoTIFF format
	Enter C-Map manipulation mode (only available when C-Map is installed)

Note

There can only be one edit button activated at a time.

Modeless operation

- To open the **Options** menu as a modal dialogue, left click the **Option** button.
- To open the **Options** menu as a modeless dialogue, hold down the CTRL key and left click the **Option** button. In this mode, you can continue to use the SIS user interface while the dialogue is open.
- To open the **Options** menu as a modeless dialogue that always remains on top of other windows, hold down the CTRL+SHIFT keys and left click the **Option** button. In this mode, you can continue to use the SIS user interface while the dialogue is open and the dialogue will always remain on top of the SIS user interface.

Note

The “modeless” operation of the Options menu is not fully implemented. If a parameter is changed via the SIS user interface while the dialog is open, the dialog will not be updated to reflect the change. For example, if you use the 'S' toolbar button toggle grid shading while the dialog is open, the grid shading setting of the Options dialog will retain its current setting. The next time you apply settings from the dialog the grid shading will be toggled back to its original setting. Although the modeless operation is not fully implemented, it has been included in this release because it is still a useful feature, because most of the actions you can perform via the SIS user interface do not affect the dialogue settings.

Quick menu

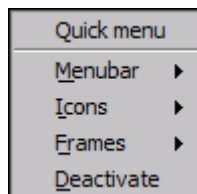

The **Geographical window** have a quick menu accessed by clicking on the right mouse button inside the view. The following features can be accessed from this menu:

- **Menubar**
 - Annotation colours
 - Dynamic colours
 - Options
 - Print
- **Icons**
 - Small icons
 - Large icons
- **Frames**
 - Empty
 - All available display frames
- **Activate/Deactivate** - toggle between Activate/Deactivate depending on the current mode of the **Geographical window**

Related operational procedures

- *How to display realtime depths* on page 161
- *How to display a smooth surface* on page 165

- *How to look for artifacts* on page 165
- *How to display seabed imagery data in the Geographical view* on page 162
- *How to create and use a GeoTIFF background image in the Geographical view* on page 166
- *How to display sound velocity at transducer depth in the Geographical view* on page 163

Parameter references

- *Geographical – Display options* on page 211
- *Geographical – Show depth under cursor* on page 222
- *Geographical – Grid shading* on page 222
- *Geographical – 2D or 3D* on page 223
- *Geographical – Inspection mode* on page 223
- *Geographical – Compass button* on page 223
- *Geographical – KSGPL edit mode* on page 223
- *Geographical – Planning edit mode* on page 224
- *Geographical – Calibration edit mode* on page 224
- *Geographical – Follow ship* on page 224
- *Geographical – Load background data* on page 224
- *Geographical – C-MAP manipulation mode* on page 225
- *Geographical – Information field* on page 225

Related topics

- *Keyboard and mouse in the Geographical view* on page 44

Beam intensity view

The **Beam intensity** window is accessed by selecting it from the **Frame selection** button or by opening it as a separate window from the **View→Tear Off** menu.

Purpose

The **Beam intensity** view gives a graphical presentation of the beam intensity and signal quality factors.

This window applies to multibeam echo sounders.

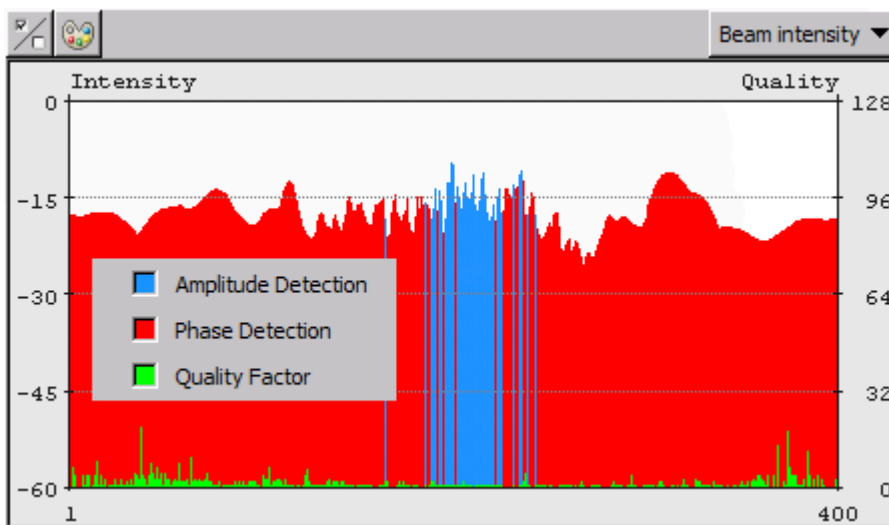

The window contains scales along the left and right vertical axes, giving the signal strength in dB values on left side and the quality measure for the data on right side. The beam numbers are shown along the horizontal axis. This number depends on the echo sounder model.

The window presents two types of bars, either red or blue, for each individual beam. The bar colour shows what type of bottom detection used for each beam; blue for amplitude detection and red for phase detection.



The value of each bar is the backscatter signal strength of the bottom presented in dB. The values are corrected for system parameters, but not for any dependence upon angle of incidence.

Normally the backscatter signal strength will be highest straight down, typically -15 dB, and lowest in the outer beams, typically -35 dB. The signal strength depends on bottom material type and roughness (± 15 dB or more).

The green bar shows a data quality measure for each beam. Small values (on a scale from 0 to 64 or 128) convey good data quality.

Toolbar buttons

The toolbar of the **Beam intensity** window holds the following buttons (from left to right):

Click this button	To
	Enter the beam intensity view's show/hide options
	Set annotation colours

Related operational procedures

- *How to verify echo sounder main functions* on page 162

Parameter references

- *Beam intensity – Show/hide* on page 227

Colour coded depth view

The **Colour coded depth** window is accessed by selecting it from the **Frame selection** button or by opening it as a separate window from the **View→Tear Off** menu.

Purpose

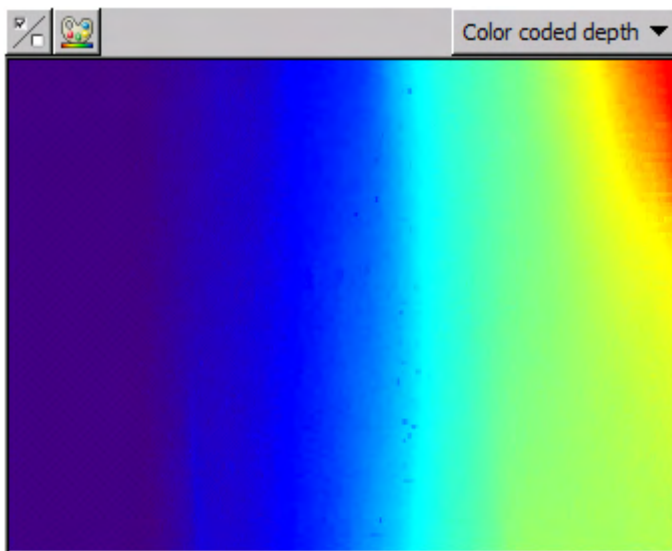

The **Colour coded depth** window shows the depth per beam shown by colour codes. A history buffer of varying size is used. The size of the history buffer depends on the size of the display. One vertical screen unit (pixel) is used per ping. Increasing the vertical size of the display area increases the number of vertical screen units, thus increasing the history buffer size.

The **Colour coded depth** window applies to multibeam echo sounders.



Toolbar button

The toolbar of the **Colour coded depth** window holds the following buttons (from left to right):

Click this button	To
	Enter the colour coded depth show/hide options
	Set dynamic colours

Parameter references

- *Colour coded depth – Show/hide* on page 227

Cross track view

The **Colour coded depth** window is accessed by selecting it from the **Frame selection** button or by opening it as a separate window from the **View→Tear Off** menu.

Purpose

The **cross track** window shows the measured depths in all beams from the last ping. This window applies to the multibeam echo sounders.

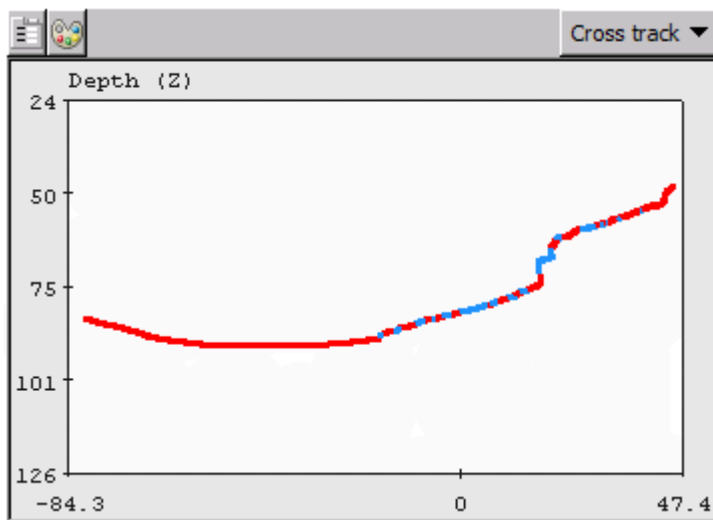



The display contains a depth scale along the left-hand (vertical) axis and beam numbers or metres along the horizontal axis.

Different colours are used to show if a beam has a valid bottom detection, and if so what type of detection has been used. Red is used to show beams with phase detection, blue is used to show beams with amplitude detection. Beams without any detection are not shown.

Toolbar buttons

The toolbar of the **Cross track** window holds the following buttons (from left to right):

Click this button	To
	Enter the cross track display options
	Set annotation colours

Modeless operation

- To open the **Options** menu as a modal dialogue, left click the **Option** button.
- To open the **Options** menu as a modeless dialogue, hold down the CTRL key and left click the **Option** button. In this mode, you can continue to use the SIS user interface while the dialogue is open.
- To open the **Options** menu as a modeless dialogue that always remains on top of other windows, hold down the CTRL+SHIFT keys and left click the **Option** button. In this mode, you can continue to use the SIS user interface while the dialogue is open and the dialogue will always remain on top of the SIS user interface.

Note

The “modeless” operation of the Options menu is not fully implemented. If a parameter is changed via the SIS user interface while the dialog is open, the dialog will not be updated to reflect the change. For example, if you use the 'S' toolbar button toggle grid shading while the dialog is open, the grid shading setting of the Options dialog will retain its current setting. The next time you apply settings from the dialog the grid shading will be toggled back to its original setting. Although the modeless operation is not fully implemented, it has been included in this release because it is still a useful feature, because most of the actions you can perform via the SIS user interface do not affect the dialogue settings.

Related operational procedures

- *How to verify echo sounder main functions* on page 162

Parameter references

- *Cross track – Display options* on page 227

Seabed image view

The **Seabed image** window is accessed by selecting it from the **Frame selection** button or by opening it as a separate window from the **View**→**Tear Off** menu.

Purpose

The **Seabed image** displays the seabed backscatter data. For each ping a straight line is plotted, this covers the swath width. The darkness of the display at any point represents the reflectivity of the bottom.

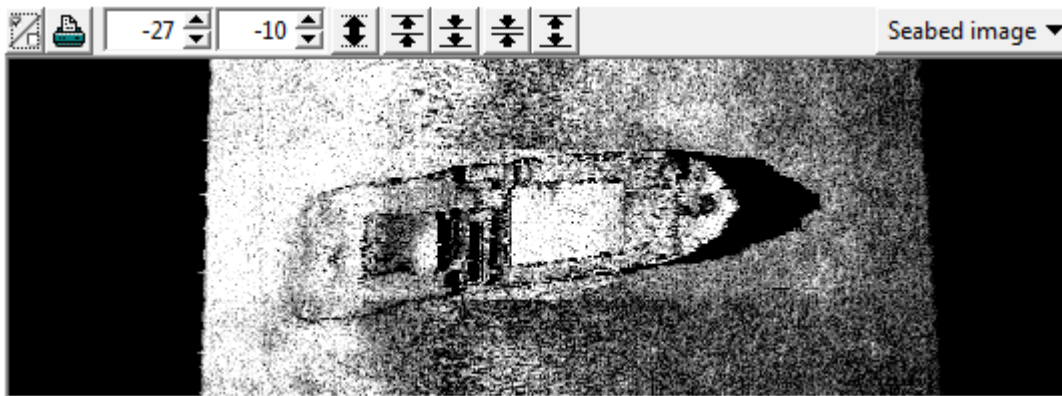







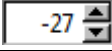
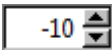

The horizontal distance between the outermost crosses in the view is set by the swath width across parameters max and min. If these are set to be ± 50 m, the total distance is 100 m. This can be used to make rough dimension estimates of artefacts on the seabed.

This window applies to the multibeam echo sounders.

Toolbar button

The toolbar of the **Seabed image** window holds the following buttons (from left to right):

Click this button	To
	Enter the seabed image show/hide options
	Print the view
	Range Minimum: Minimum value of dynamic range used for computing colour map for display. Use the arrows to increase/decrease or enter the value.
	Range Maximum: Maximum value of dynamic range used for computing colour map for display. Use the arrows to increase/decrease or enter the value. The maximum value will not exceed 0 dB.
	Automatically set the range minimum and maximum values. The current maximum and minimum values of beam intensity from the most recent depth datagram are used (these values are shown in the beam intensity display). However, the minimum range window size (for range auto) is limited to 20 dB, so the maximum and/or minimum values may be adjusted if necessary to satisfy this criteria.
	Move the range up (in dB) by increasing both the range minimum value and range maximum value by 1 dB. The maximum value will not exceed 0 dB, so the range will not be moved up past this point.
	Move the range down (in dB) by decreasing both the range minimum value and range maximum value by 1 dB.
	Narrow the range by decreasing the range maximum by 1 dB and increasing the range minimum by 1 dB.
	Widen the range by increasing the range maximum by 1 dB and decreasing the range minimum by 1 dB. The maximum value will not be increased past 0 dB.

Parameter references

- *Seabed image – Show/hide* on page 231

Numerical display

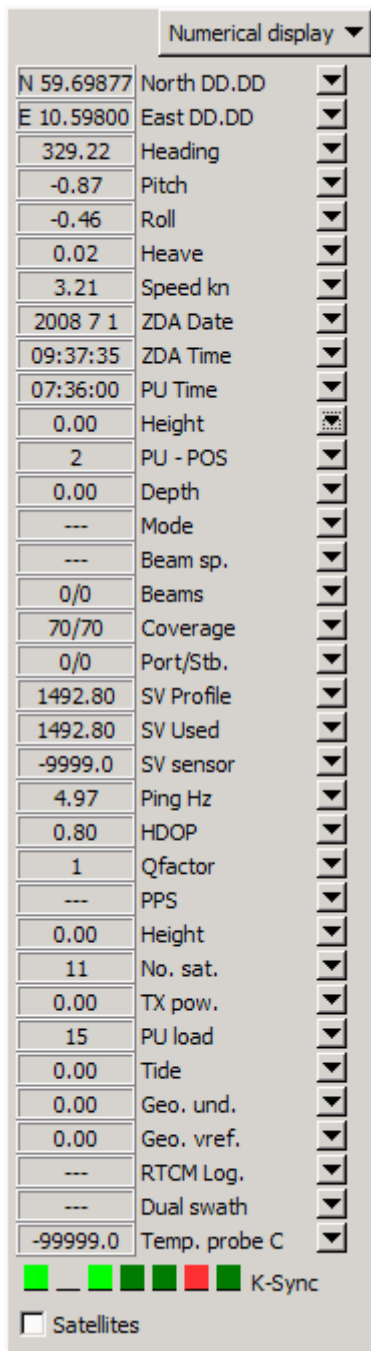

The **Numerical display** window is accessed by selecting it from the **Frame selection** button or by opening it as a separate window from the **View→Tear Off** menu.

The **Numerical display** window allows you to monitor various SIS parameters. The parameters cannot be changed here. Exceeded limits are shown by red.

If you press the button next to the text, an alphabetically ordered list with selectable parameters will appear. Choose the parameter you want to monitor.

This window applies to all instruments.

Some parameters applies to specific instruments only.

Related operational procedures

- *How to monitor the external sensors in SIS on page 160*
- *How to monitor the survey progress on page 202*
- *How to verify echo sounder main functions on page 162*

Parameter references

- *Numerical display on page 232*

Message service view

The **Message service** window is accessed by selecting it from the **Frame selection** button or by opening it as a separate window from the **View→Tear Off** menu.

Purpose

The **Message service** instantaneously displays and logs all system generated information, warnings and error messages. The automatic generated log files are store in `..sisdata/common/message/auto`.

This window applies to all instruments.

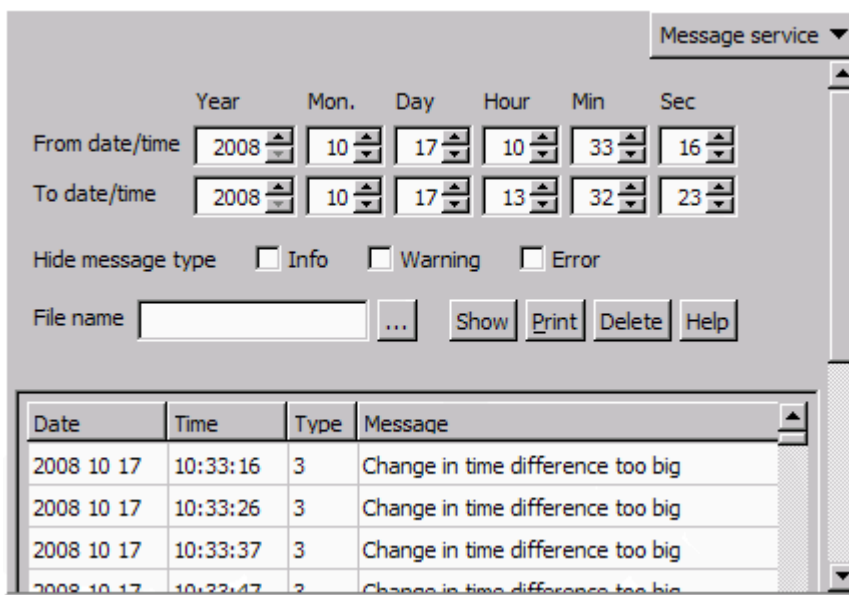

Related operational procedures

- *How to monitor the external sensors in SIS* on page 160
- *How to monitor the survey progress* on page 202

Helmsman display view

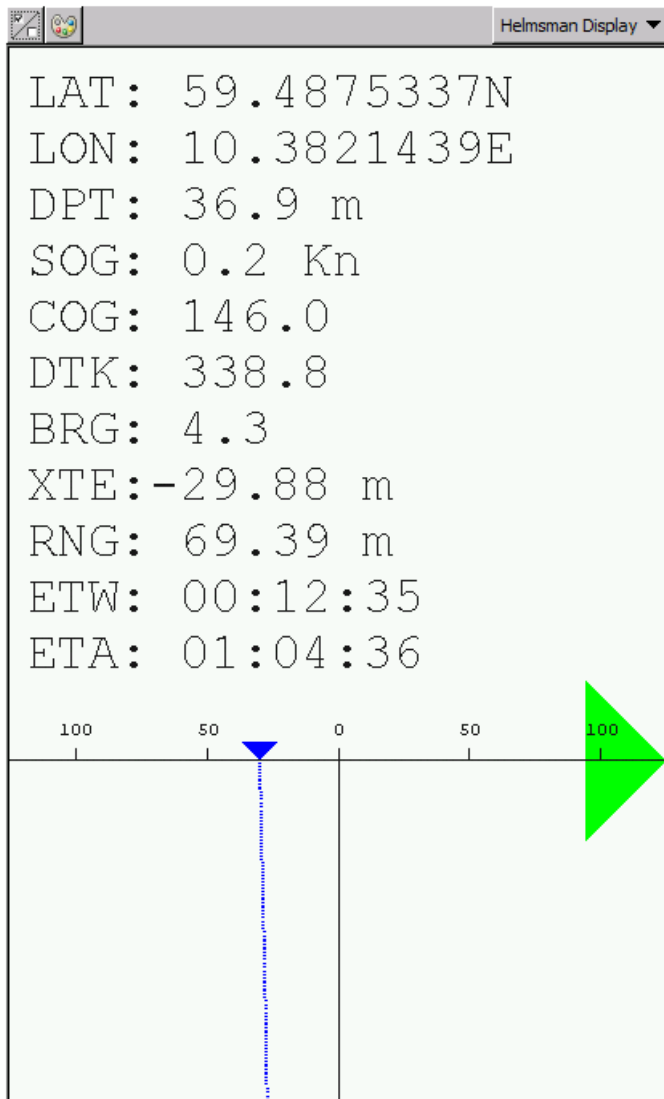

The **Helmsman Display** window is accessed by selecting it from the **Frame selection** button or by opening it as a separate window from the **View→Tear Off** menu.

Purpose

The **Helmsman Display** provides steering guidance of the ship relative to planned survey lines.

This window applies to all instruments.

A line may have several waypoints, and the DTK, XTE, CMG and DST deviation indicators all show their values to the next waypoint or to the current line segment. The scale changes automatically. Red and green arrows indicate that the helmsman have to steer port or starboard to relocate. Before the ship reaches the start of the line, the indicator will form an arrow pointing downwards.

When reaching the end of the line (or before entering the line) the Helmsman Display will continue to display the ship's



position relative to the continuation of the last line segment of the planned line.

Note

The Helmsman display must be active when SIS is controlling the Autopilot.

Toolbar buttons

The toolbar of the **Helmsman display** window holds the following buttons (from left to right):

Click this button	To
	Enter the helmsman display show/hide options
	Set annotation colours

Related operational procedures

- *How to start the Remote Helmsman Display* on page 206
- *How to plan a new job in SIS* on page 201
- *How to retrieve a planned job* on page 202
- *How to display planned lines on the Remote Helmsman Display* on page 206

Parameter references

- *Helmsman display – Show/hide* on page 237

Time series view

The **Time series** window is accessed by selecting it from the **Frame selection** button or by opening it as a separate window from the **View→Tear Off** menu.

Purpose

The **Time Series** window is used for presenting external interfaces or depth information as time series. Information from one or more sensors or beams can be selected.

Time series may be useful for detection of incorrect performance of the sensors or of incorrect depth determination.



Toolbar buttons

The toolbar of the **Time series** window holds the following buttons (from left to right):

Click this button	To
	Enter the time series show/hide options
	Set annotation colours
	Clear plot

Related operational procedures

- *How to monitor the external sensors in SIS* on page 160

Parameter references

- *Time series – Show/hide* on page 238
- *Time series – Clear plot* on page 241

Waterfall view

The **Waterfall** window is accessed by selecting it from the **Frame selection** button or by opening it as a separate window from the **View→Tear Off** menu.

Purpose



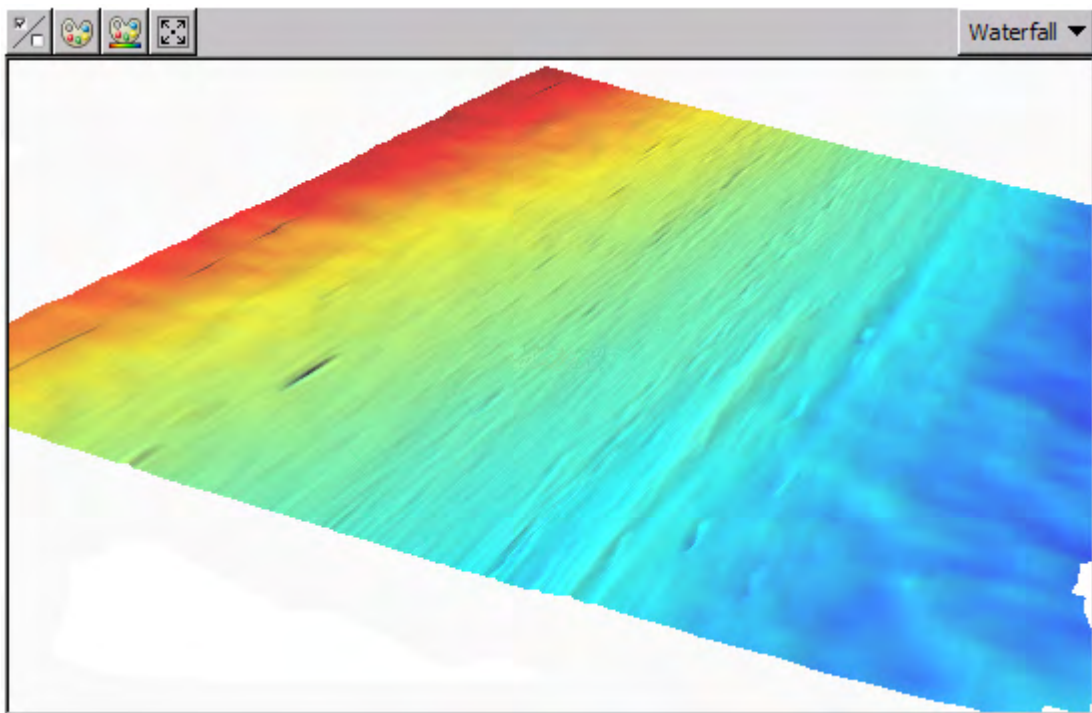

In the **Waterfall** window the depth profiles from a number of pings are displayed as a function of across-track horizontal distance with a small vertical offset between each profile. This gives a crude 3D representation of the most recently measured bottom area.



Note that the colour coding applied to the profiles shows depth levels, not bottom detection.

Toolbar buttons

The toolbar of the **Waterfall** window holds the following buttons (from left to right):

Click this button	To
	Enter the Waterfall show/hide options
	Set annotation colours
	Set dynamic colours
	Reset the view

Related operational procedures

- *How to verify echo sounder main functions* on page 162

Parameter references

- *Waterfall – Show/hide* on page 241

Related topics

- *Keyboard and mouse in the Waterfall view* on page 45

Water column view

The **Water column** window is accessed by selecting it from the **Frame selection** button or by opening it as a separate window from the **View→Tear Off** menu.

Purpose

The Water column display shows a graphical image of biomass and other acoustic reflectors that might be present in the water column. The received amplitude of the reflected signal through the entire water column for each beam is presented. The vertical scale on the left of the display shows the depth in metres. The horizontal scale along the bottom of the display shows the across track distance in metres. The seafloor is shown as a yellow or red band in the data view.

The display may be found useful for debugging and for habitat monitoring.

A TVG function (x log) is applied to the data.

The **water column** window applies to multibeam echo sounders with water column capabilities.

There is a short-cut to forcing the bottom detection around the depth selected by the mouse.

There is also a short cut to select scope display beam number.

Related topics

- *Keyboard and mouse in the Water column view* on page 46

Figure 7 Water column data with associated seabed image – passing a wreck

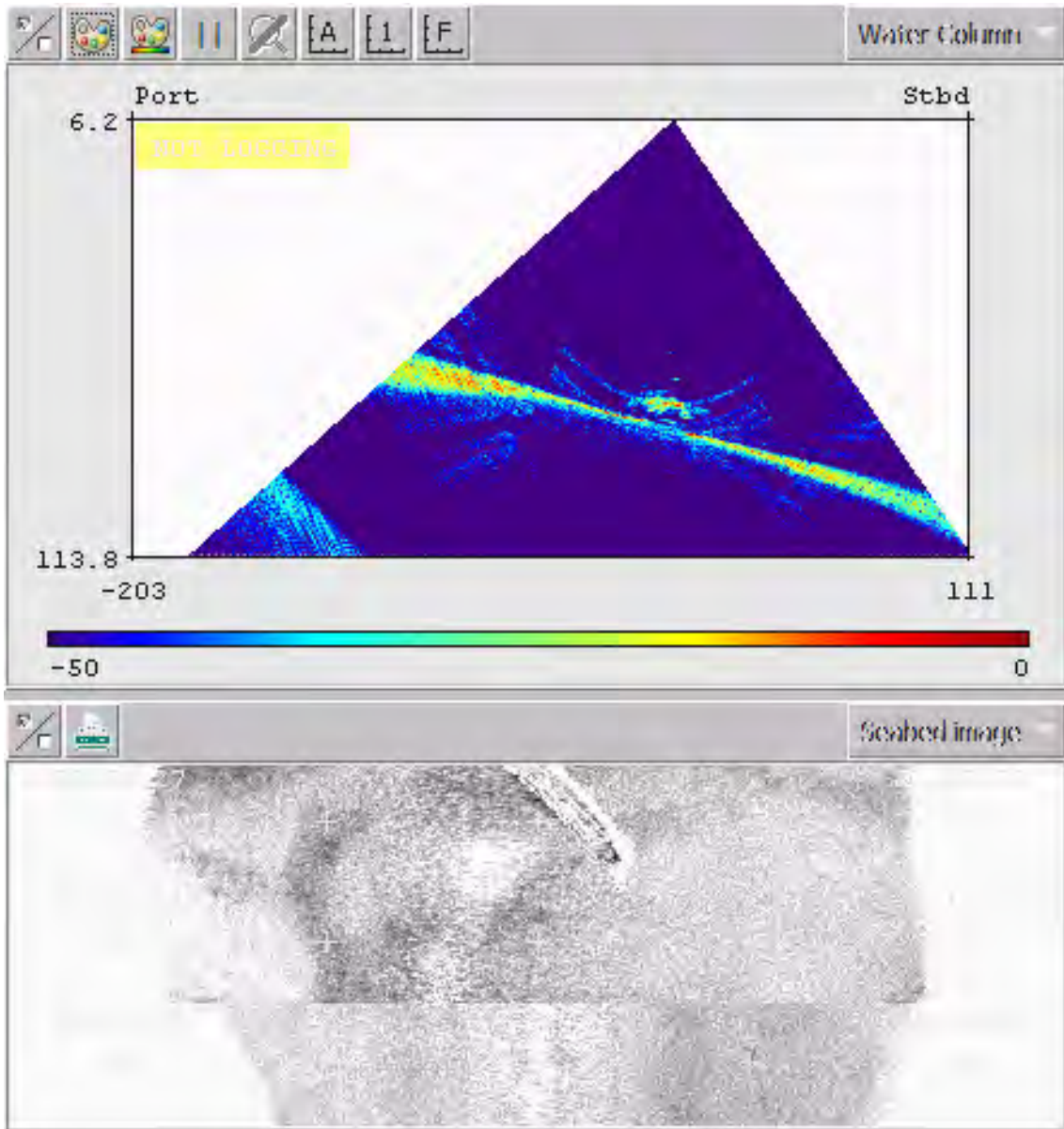

Note

Sound velocity corrections and ray bending corrections are not applied.

Water column logging

Water column data can selectively be logged to either the standard log file (.all) or to a separate water column file (.wcd). Water column datagrams can not be logged to both files simultaneously.

Water column logging to separate file must be enabled in the **Output setup** tab under **Installation parameters**.

Logging is toggled on/off from the **Main toolbar**.

Please note that the logged data amount is very large, that is, typically 1 to 2 Gigabytes per hour.

Separate water column data (.wcd) files may optionally be logged to a disk different from the one used for the raw data (.all) files. Water column data file locations are set from the **Logging** option accessed from **Tools**→**Custom**→**Set Parameters** for details.

Zooming

It is possible to zoom in to a region of the grid by clicking the left mouse button and dragging a rectangle around a region of the grid. When the left mouse button is released, the region of the grid to which you have zoomed will be displayed.

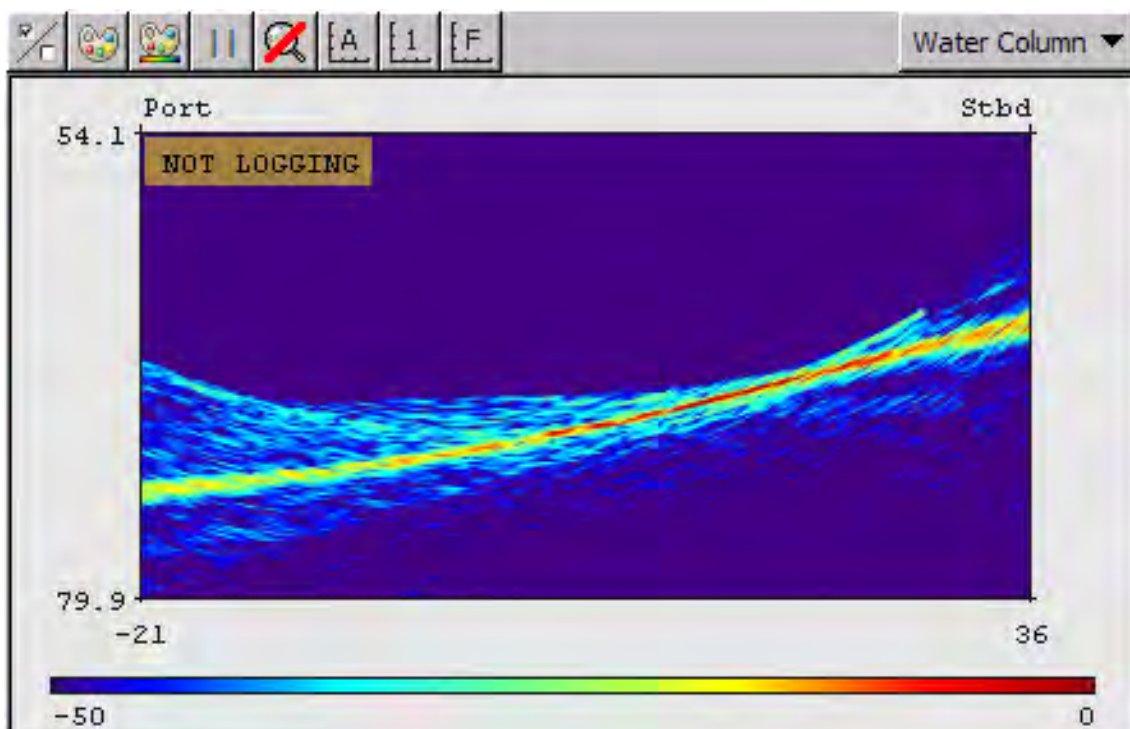









Note that the **Zoom Reset** button now will be enabled, i.e. not longer dimmed. It is possible to zoom in even further, by clicking and dragging a rectangle inside the zoomed region.

To reset the zoom, click the **Zoom Reset** button. This will return the display to original scale. You can also reset the zoom by selecting one of the auto range options from the **Show/Hide** dialogue.

Toolbar buttons

The toolbar of the **Water column** window holds the following buttons (from left to right):

Click this button	To
	Enter the Water Column show/hide options
	Set annotation colours
	Set dynamic colours
	Pause the water column display
	Reset zoom
	Scale the axes automatically
	Scale the axes to currently received data
	Scale the axes to fixed values

Related operational procedures

- *How to verify echo sounder main functions* on page 162
- *How to log water column data* on page 170

Parameter references

- *PU communication – Output setup* on page 279
- *Water column – Show/hide* on page 243
- *Water column – Logging* on page 247
- *Logging* on page 341

Related topics

- *Keyboard and mouse in the Water column view* on page 46

Sound velocity profile view

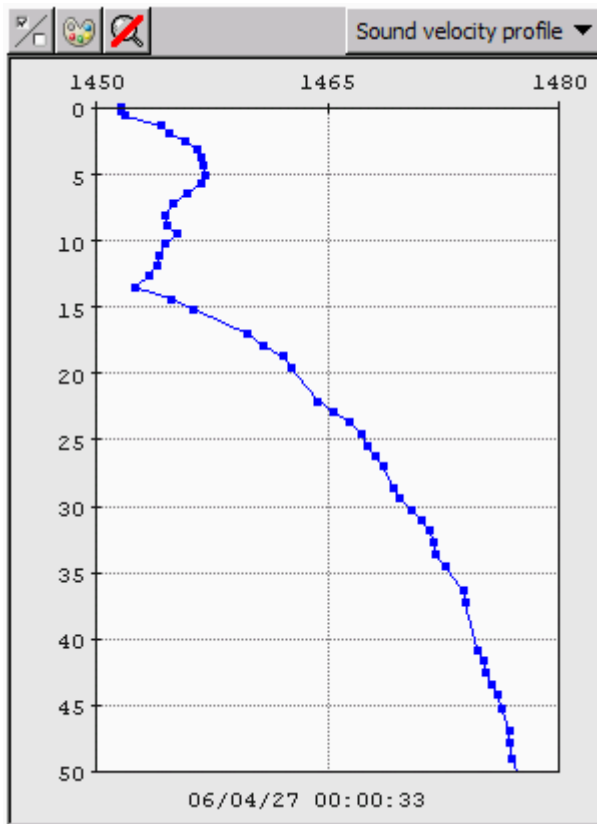

The **Sound velocity profile** window is accessed by selecting it from the **Frame selection** button or by opening it as a separate window from the **View→Tear Off** menu.



Purpose

The **Sound velocity profile** window is used for displaying the sound velocity profile being used by the multibeam echo sounder. It is not an editor.

The profile is a sequence of points. These have coordinates with increasing depth values.

Toolbar buttons

The toolbar of the **Sound velocity profile** window holds the following buttons (from left to right):

Click this button	To
	Enter the Sound Velocity Profile show/hide options
	Set annotation colours
	Reset zoom

Related operational procedures

- *How to monitor the external sensors in SIS* on page 160
- *How to collect the sound velocity profile* on page 141
- *How to convert your sound velocity profile to SIS format* on page 143
- *How to modify and load a sound speed profile into SIS* on page 151
- *How to display sound velocity at transducer depth in the Geographical view* on page 163

Parameter references

- *Sound velocity profile – Show/hide* on page 247

Related topics

- *Keyboard and mouse in the Sound velocity profile view* on page 45

- *SVP Editor* on page 395.

Scope display

The **Scope display** window is accessed by selecting it from the **Frame selection** button or by opening it as a separate window from the **View→Tear Off** menu.

Purpose

The **Scope display** is used for investigating the receiver echo data. It is mainly used for test purposes. The data is not logged.

The Scope display window applies to all multibeam echo sounders.

The data is presented as an xy series, having time on the horizontal x-axis and receiver echo level on the vertical y-axis. Beams close to normal incidence will have short echo and a noisy split beam phase signal. The outer beams will normally have a long echo and a well-defined phase curve. The range for the bottom detection is indicated by a vertical dotted line. Amplitude detection, filtered amplitude detection and phase detection are plotted.

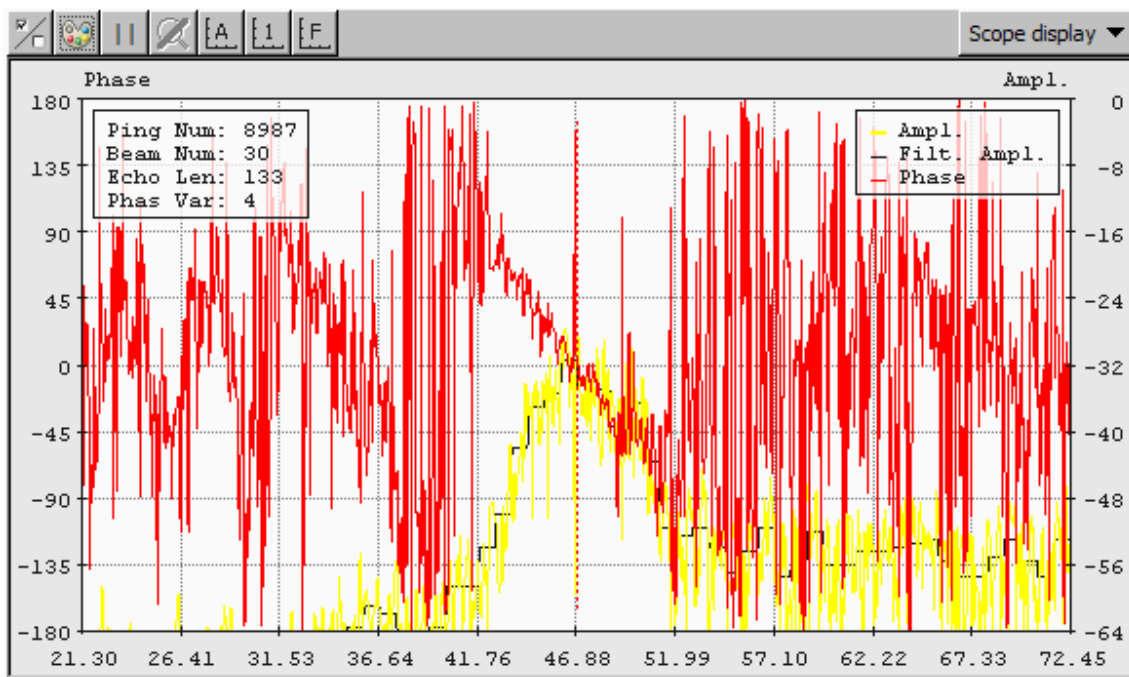







Beam number to investigate is selected from **Runtime parameters→Simulator**. For system with dual swath capability the Swath number for the Scope Display is also selected from here.

The example above shows a phase detection for beam number 30.

Toolbar buttons

The toolbar of the **Scope display** window holds the following buttons (from left to right):

Click this button	To
	Enter the Scope display show/hide options
	Set annotation colours
	Pause the scope display
	Reset zoom
	Scale the axes automatically
	Scale the axes to currently received data
	Reset zoom

Parameter references

- *Scope display – Show/hide* on page 247

Stave display

The **Stave display** window is accessed by selecting it from the **Frame selection** button or by opening it as a separate window from the **View→Tear Off** menu.

Purpose

The **Stave display** window shows a graphical presentation of the status of all the receiver elements or staves in the multibeam. The number of staves varies from multibeam to multibeam.

The Stave display can be helpful for debugging and verifying the performance of a system, establishing if there is interference from other systems, if there are air bubbles etc. The data is not logged.

This window applies to multibeam echo sounders with stave display capabilities.

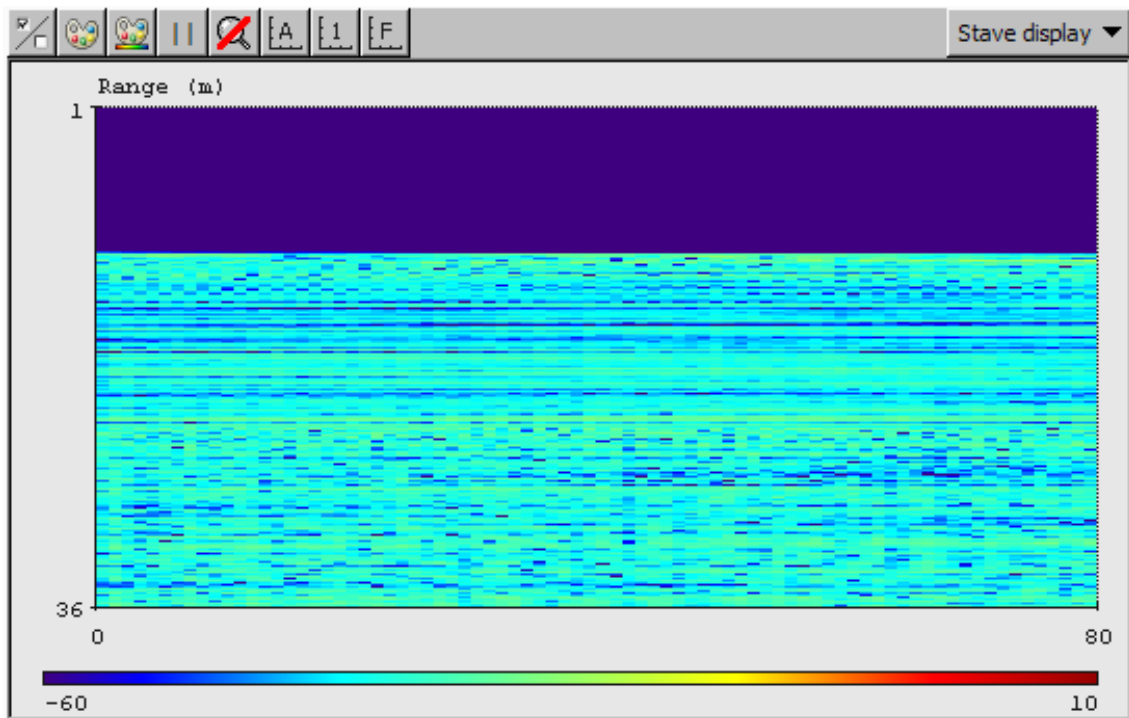









The Stave display presents a grid in which each row of the grid corresponds to one data sample, and each column in the grid corresponds to one receive stave. Each grid cell shows the received signal level for the corresponding sample and stave.

The scale along the left vertical axis shows the sample number, the scale along the right vertical axis shows the range in meters, and the scale along the horizontal axis at the bottom shows the stave number.

Toolbar buttons

The toolbar of the **Stave display** window holds the following buttons (from left to right):

Click this button	To
	Enter the Scope display show/hide options
	Set annotation colours
	Set dynamic colours
	Pause the scope display
	Reset zoom
	Scale the axes automatically
	Scale the axes to currently received data
	Reset zoom

Zooming

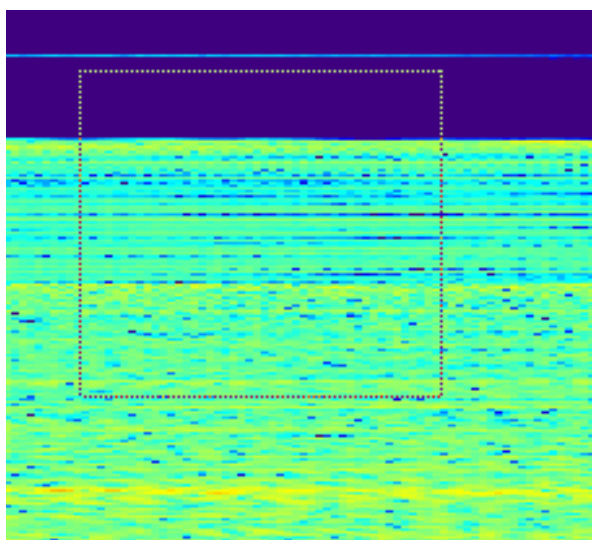

You may zoom in to region of the grid by clicking the **left mouse** button and dragging a rectangle around a region of the grid.

When the left mouse button is released, the region of the grid to which you have zoomed will be displayed. Note also that the **Zoom Reset** button will now be enabled (i.e. it is no longer dimmed). It is possible to zoom in even further by clicking and dragging a rectangle inside the zoomed region.

To reset the zoom, click the **Zoom Reset** button. This will return the display to the scaling mode that

existed prior to the original zoom operation. You can also reset the zoom by selecting one of the auto range options from the **Show/Hide** dialogue.

Displaying cell information

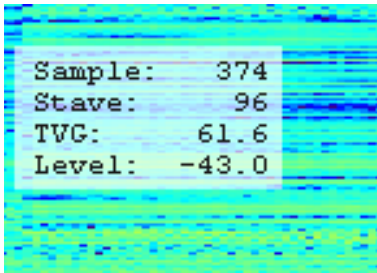

It is possible to display the sample number, stave number, TVG and level for any grid cell. To display the cell information, hold down the **Ctrl** key and click **left mouse** button on the desired grid cell. Because the size of the grid cells sometimes is very small (down to several cells per screen pixel), it may be necessary to first zoom into a region of the grid before clicking on a cell.

The cell information will remain on the screen and will be updated in real time as stave data is received until the user left clicks somewhere inside the grid.

The user can repeatedly display cell information for several cells by holding down the **Ctrl** key and repeatedly clicking **left mouse** button on different grid cells. In this case, it may be helpful to pause the display first (otherwise the data will continue to be updated in real time).

TVG curve

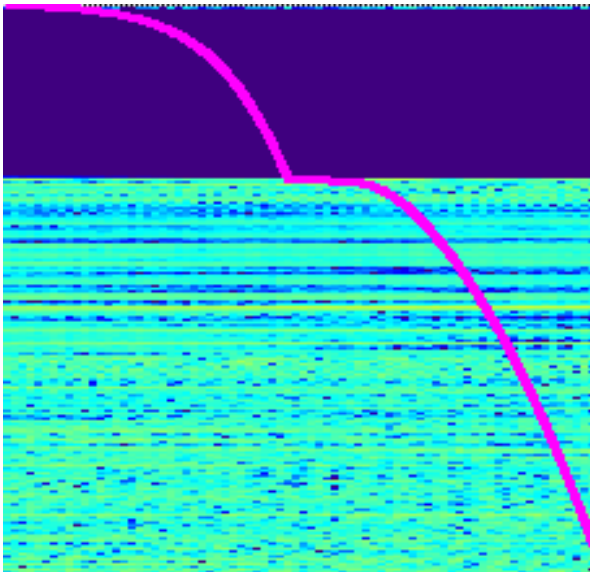

It is possible to display the TVG (Time Varying Gain) curve on top of the stave data. The TVG curve can be shown or hidden from the **Show/Hide** dialogue. The TVG curve scale is not shown, however it is possible to determine the TVG value at any location on the curve by pressing the **Ctrl** key and **left mouse** button on that location on the curve.

Parameter references

- *Stave display – Show/hide* on page 249

PU sensor status view

The **PU sensor status** window is accessed by selecting it from the **Frame selection** button or by opening it as a separate window from the **View→Tear Off** menu.

Note

*The **PU – Processing Unit** may be a separate hardware unit or an integrated part of the **TRU – Transceiver Unit** cabinet, depending on echo sounder system.*

*For **SIS** it makes no difference whether the communication is with a **PU** or a **PU** inside a **TRU**. The term **PU** is used in this manual.*

The window is intended for giving an overview of the current reception status of all selected sensor inputs on a **PU**. It shows which sensors are selected as active sensors. The information refers to the **PU** (Processing Unit) of the echo sounder selected as **Current echo sounder** combo box in the **Main** toolbar.

PU Sensor input status

	COM1	COM2	COM3	COM4	UDP2	UDP5
GGA	P					
GGK						
GGA_RTK						
GST						
SIMRAD90						
Attitude		HM				
MK39 Mod2 Attitude, no heave						
HDT Heading						
SKR82 Heading						
ROV. depth						
ZDA Clock						
Height, special purpose only						
DBS Depth						
DBT Depth						
EA500 Depth						
ATTVEL						
1PPS Clock Synch.						

P = active position sensor
 M = aktiv motion/attitude sensor
 H = active heading sensor

Reload

The status information is presented as a matrix with columns with the PU input ports and a row for each of the available sensor types. The settings in this matrix reflects the settings in the Installation parameters frame (i.e. **Installation parameters**→**PU Communication Setup**→**Input Setup**). Colours are used to represent the status as follows:

White:	Combination not selected.
Green:	Input from sensor selected and received
Red:	Input from sensor selected, but not received.
Yellow:	Input from sensor selected and received but having poor quality.

Any letters in the marked combinations are used to indicate which combination is set as the active sensor. Different letters are used in the different supported languages. The English equivalents are:

P:	The marked combination is set as active position sensor.
M:	The marked combination is set as active motion attitude sensor.
H:	The marked combination is set as active heading sensor.

The display is updated with a frequency of 1 Hz and any changes done in the **Installation parameters** frame will be reflected.

Errors (red indications) and poor quality (yellow indications) will be reported to the error message system and may be viewed in the **Message Service** frame. The problem will also be indicated by setting the appropriate colour (red or yellow) in the PU status lamp in the **Main toolbar** in SIS. Errors will have priority over bad quality in the lamp setting.

Note

Poor quality will only be reported for sensors selected as active.

PU sensor input status frame will only contain information for a PU if the PU has been started (i.e. selected in the “Not Started” combo box in the “Main toolbar”).

PU Sensor logging

Logging of the received sensor data from a selected port can be started by pressing Shift+Ctrl+Alt+RightMouseButton.

Related operational procedures

- *How to monitor the external sensors in SIS* on page 160

Parameter references

- *PU communication – Input setup* on page 275

Related topics

- *Main toolbar* on page 33
- *Current echo sounder* on page 36
- *Message service view* on page 69
- *PU sensor input logging* on page 440

New survey window

The **New survey** window is accessed by selecting it from the **Frame selection** button or by opening it as a separate window from the **View→Tear Off** menu.

Purpose

The **New survey** setup guides you through the configuration of all essential survey parameters. These include projection data, background maps, storage location and data gridding parameters. These are parameters that are vital for the data acquisition, and incorrect settings may not be possible to correct for in post processing.

Note

*To avoid having to set all the survey parameters every time a new survey is created, we advise you to define your own Survey template from the **Survey administration** window, and select this template as basis for your new survey.*

The **New survey** parameters can be saved to current or all survey templates, and it is thereby not required to set the survey parameters more than once for a survey.

The **New survey** window contains the following tab-menus:

- **Basic parameters** – used to create and identify the new survey. The GridEngine Parameters are used to set the cell size when using the **GridEngine** gridding method
- **Storage options** – used to specify parameters for SIS raw data logging
- **Advanced options** – contains the following sub-tabs:
 - Background data – used to specify background data such as projection, background map, tide and geoid data
 - Projections – used to specify what datum and projection to use for the survey

The parameters defined under **New survey** may also be accessed from the **Survey administration** window, the difference being that the **New survey** parameters applies to that survey definition only, whereas the **Survey administration** parameters applies to templates.

Related operational procedures

- *How to configure your survey* on page 113
- *How to enter parameters for a new survey* on page 118
- *How to enter survey parameters* on page 114
- *How to define a new projection and datum transformation* on page 122

Parameter references

- *Basic parameters* on page 263
- *Storage options* on page 265
- *Background data* on page 267
- *Projection parameters* on page 269
- *GridEngine parameters* on page 269

Related topics

- *Survey administration window* on page 91

Survey administration window

The **Survey administration** window is accessed by selecting it from the **Frame selection** button or by opening it as a separate window from the **View→Tear Off** menu.

Purpose

The **Survey administration** setup allows you configuration of all essential survey parameters. These include projection data, background maps, storage location and data gridding parameters. These are parameters that are vital for the data acquisition, and incorrect settings may not be possible to correct for in post processing.

In addition, the **Survey administration** is an administrative tool for handling several survey templates.

The **Survey administration** window contains the following tab-menus:

- **User handling** – used to identify the SIS user of the survey
- **Background data** – used to specify background data such as projection, background map, tide and geoid data
- **Survey template handling** – contains the same sub-tabs as found in the **New survey** window:
 - Basic parameters – administrative data for the available survey templates
 - Storage options – used to specify parameters for SIS raw data logging
 - Advanced options – contains the following sub-tabs:
 - * Background data – used to specify background data such as projection, background map, tide and geoid data
 - * Projections – used to specify what datum and projection to use for the survey
 - * GridEngine Parameters – used to set the cell size when using the **GridEngine** gridding method
 - * CUBE parameters – used to set the grid specifications when CUBE is being used

Related operational procedures

- *How to configure your survey* on page 113
- *How to enter parameters for a new survey* on page 118
- *How to enter survey parameters* on page 114
- *How to define a new projection and datum transformation* on page 122

Parameter references

- *Basic parameters* on page 263
- *Storage options* on page 265
- *Background data* on page 267
- *Projection parameters* on page 269
- *GridEngine parameters* on page 269
- *User handling* on page 272

- *CUBE parameters* on page 273

Related topics

- *New survey window* on page 89
- *CUBE* on page 464

Planning module window

The **Planning module** window is accessed by selecting it from the **Frame selection** button or by opening it as a separate window from the **View→Tear Off** menu.

Purpose

The **Planning module** in SIS is a tool that can be used to create and display survey lines. These can be parallel lines, lines within a polygon or turns. The lines can be edited, changed direction of, extended or cut. Guidance information relative to the active survey line can be sent to the Helmsman display.

Note

All planning buttons are disabled until this the Planning module is activated by:

- 1 Select **Planning** from the Show/Hide option of the Geographical window*
 - 2 Press the **Planning** button **P***
-

Planning features

The Planning module has three elements:

- Jobs – used to create and save a new job, or to reactivate an existing job
- Remote – used to transfer data to a remote Helmsman Display
- Objects – used to create and manipulate lines and polygons within an existing job

Related operational procedures

- *How to plan a new job in SIS* on page 201
- *How to retrieve a planned job* on page 202
- *How to display planned lines on the Remote Helmsman Display* on page 206

Parameter references

- *Planning – Jobs* on page 251
- *Planning – Remote* on page 251
- *Planning – Object* on page 251

Related topics

- *Keyboard and mouse in the Planning module view* on page 44

Installation parameters window

The **Installation parameters** window is accessed by selecting it from the **Frame selection** button or by opening it as a separate window from the **View→Tear Off** menu.

Note

Pinging must be Off to configure the Installation Parameters

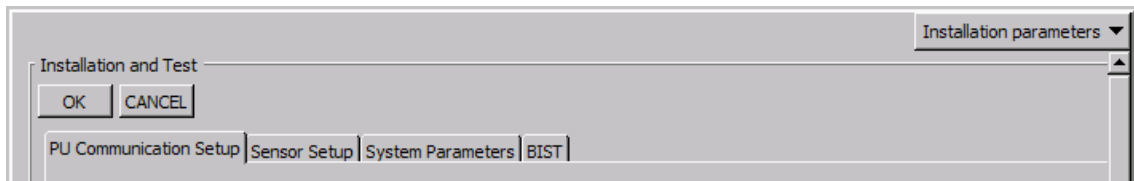

Purpose

The **Installation parameters** window is used to set parameters for all navigation systems, motion sensors and sonar heads or transducers connected to the hydrographic system. These parameters include:

- **Sensor locations (x, y, z):** Used to input the relative locations of the sensors
- **Angular offsets:** Input of installation angles of the sensors
- **Waterline reference:** Definition of the ship's draft relative to the sensors
- **Position input system:** Setup of position input
- **Clock reference:** Definition of clock source
- **System parameters:** Used for setting up Tx and Rx opening angles and backscatter parameters
- **PU input/output datagrams:** Definition and setup of input and output datagrams
- **BIST:** Used for doing the Built-In Self Tests

Related operational procedures

- *How to open the installation parameter interface* on page 127
- *How to modify the installation parameters* on page 127

Parameter references

- *PU communication – Input setup* on page 275
- *PU communication – Output setup* on page 279
- *PU communication – Clock setup* on page 281
- *Sensor setup – Settings* on page 283
- *Sensor setup – Location for EM 2040* on page 288
- *Angular Offsets for EM 2040* on page 290
- *ROV Specific for EM 2040* on page 291
- *System parameters for EM 2040* on page 292
- *BIST – Built-In Self Test* on page 293

Runtime parameters window

The **Runtime parameters** window is accessed by selecting it from the **Frame selection** button or by opening it as a separate window from the **View→Tear Off** menu.

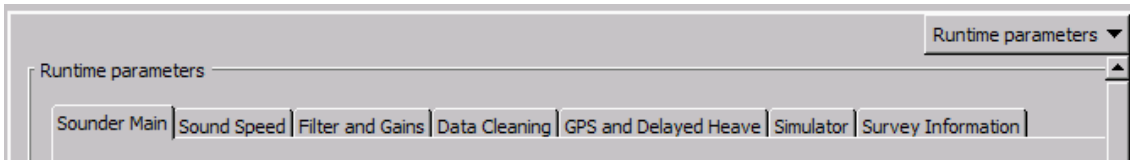

The contents of the window will differ, depending on the echo sounder system.

Equipment with a Processing Unit (i.e. all multibeam echo sounders) contains parameter setting pages for the following features:

- **Sounder main:** Used to set ping mode, swath coverage, beam spacing, depth and stabilization
- **Sound speed:** Used to enter the applicable sound speed data
- **Filter and gains:** Used to set what filter method and absorption coefficient to apply
- **Data cleaning:** Configuration of what rules to apply for data cleaning, ping processing, grid processing and for seabed image processing
- **GPS and delayed heave:** Used for configuration of logging files related to positioning and attitude data that optionally can be used in post processing.
- **Simulator:** Parameters for simulator mode.
- **Survey information:** Displays survey parameters for current survey.

In addition to the full Runtime parameters window described in this section a scaled down window with only a subset of essential parameters are also available. This reduced runtime parameters window will occupy very little space, still allowing you easy access to basic runtime settings:

- See *Runtime parameters mini view* on page 96

Related operational procedures

- *How to open the runtime parameter interface* on page 134
- *How to modify the runtime parameters* on page 134

Parameter references

- *Sounder main for EM 2040* on page 297
- *Sound speed for EM 2040* on page 305
- *Filter and gains for EM 2040* on page 310
- *Data cleaning* on page 317
- *GPS and delayed heave* on page 323
- *Simulator for EM 2040* on page 329
- *Survey Information* on page 332

Runtime parameters mini view

The **Runtime param. Mini** frame is accessed by selecting it from the **Frame selection** button or by opening it as a separate window from the **View→Tear Off** menu.

The **Runtime Parameters Mini** frame provides easy access to most commonly used parameters of the Runtime Parameters.

The parameters available in the **Runtime Parameters Mini** frame is a selection from the **Sounder Main** tab in the full **Runtime parameters** window.

Runtime parameters Mini – EM 2040

When the parameters are changed, the background is marked using yellow colour. Press enter on the keyboard, or make a selection in a combo box, to confirm and send the parameters to the echo sounder (PU).

Note

When using the buttons in continuous mode no range checking will be made on the changed parameter values. The parameters can therefore be set outside valid bounds. However, when the button is released and you press enter to confirm, a single press on the same button or editing of another parameter will cause an error message to appear if the parameter is set outside valid boundaries.

Mini and full Runtime parameters frame synchronization

The Mini window can be displayed together with the full Runtime parameters window. If a change is made and confirmed in one of the two windows the other window will be updated automatically, keeping the windows synchronised.

Related operational procedures

- *How to open the runtime parameter interface on page 134*
- *How to modify the runtime parameters on page 134*

Parameter references

- *Sounder main for EM 2040* on page 297

Sensor layout view

The **Sensor layout** window is accessed by selecting it from the **Frame selection** button or by opening it as a separate window from the **View→Tear Off** menu.



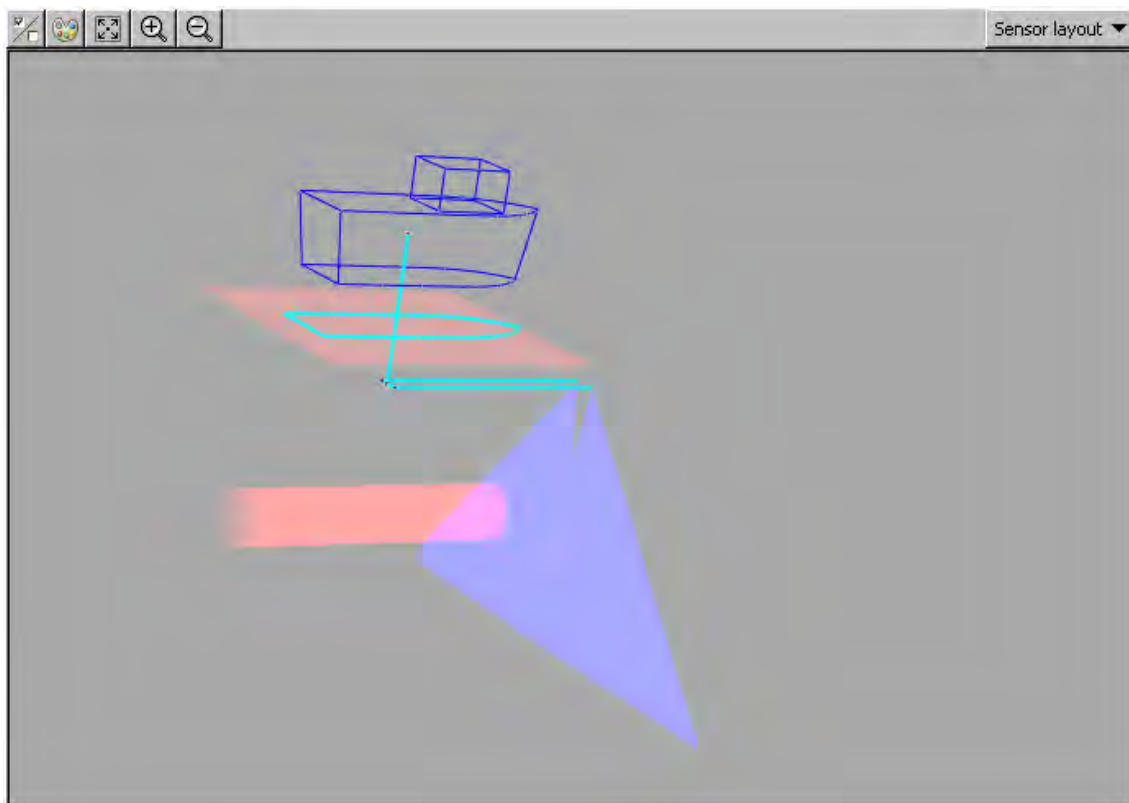

Purpose

The **Sensor layout** gives a graphical presentation of the sensor locations on the ship which may be useful to verify installation parameters.



Toolbar buttons

The toolbar of the **Sensor layout** window holds the following buttons (from left to right):

Click this button	To
	Enter the Sensor Layout show/hide options
	Set annotation colours
	Reset the view
	Zoom in
	Zoom out

Related operational procedures

- *How to monitor the external sensors in SIS* on page 160

Parameter references

- *Sensor layout – Show/hide* on page 258

Related topics

- *Keyboard and mouse in the Sensor layout view* on page 45

Calibration view

Note

The SIS calibration frame is designed for determination of sensor angular offsets. It is NOT intended for determining the angular orientation of the system transducers. These must be determined through measurements as described in the installation manual. The reason for this is that it is not possible to do a linear addition of sensor offsets and transducer orientation angles.

The only exception to this is if the transducers are oriented such that they have zero heading and pitch installation angles, i.e. that they lie horizontal when the pitch is zero and are mounted parallel to the keel, in which case receive transducer roll installation angle and sensor roll offset act as a linear sum. This may be exploited in temporary installations where it may be very difficult to measure roll installation angles with sufficient accuracy.

The calibration is neither intended for finding remaining errors in XYZ locations of the sensors. Accurate locations of the sensors must be determined using land survey methods as described in the systems installation manual.

The **Calibration** window is accessed by selecting it from the **Frame selection** button or by opening it as a separate window from the **View→Tear Off** menu.

Purpose

The **Calibration** window is intended for analysis of data from a calibration survey, i.e. a survey to determine remaining biases in the depth observations. Depths from two different survey lines is compared in order to visualise the effect of the correction. Please refer to related operational procedures for description of the principles of a calibration survey.

The **Calibration** features of SIS can be run both during online and offline operations.



Note

*No correction values will be applied until these are entered in the **Installation Parameters** frame*

The **Calibration** frame applies to multibeam echo sounders only.

Toolbar buttons

The toolbar of the **Calibration** frame holds the following buttons (from left to right):

Click this button	To
	Enter the Calibration show/hide options
	Reset zoom

Buttons

- **Set:** Apply changes to the corridor width.
To change the corridor width, enter a new value and press **Set**. If you select a new corridor, the previously used offsets will be applied and corrected data will be displayed in the diagram.
- **Apply:** Calculate and display the data points after setting new offsets.
- **Store:** Save the new offsets in the database.
- **Auto Calib:** If licensed this button brings up the dialogue to enter parameters to be used by **SeaCal**.

Quick menu

The Calibration window have a quick menu accessed by clicking on the right mouse button inside the view.

- Select shiptracks - First select two lines using Ctrl + Left mouse button.
- Create corridor - Then create a corridor using Ctrl + Left mouse button.

The system will now calculate and display the two lines from raw data. For a dual system one head at a time must be calibrated.

Seacal auto calibration

If licensed the **AutoCalib** button brings up the dialogue to enter parameters to be used by **SeaCal**.

AutoCalib may be used as an alternative to the visual determination of correction values as offered by the **Calibration** frame. It is also a useful tool for verifying the correction values found by the visual method.

Related operational procedures

- *Roll offset in the acrosstrack direction* on page 173
- *Pitch offset and time delay* on page 174
- *Heading offset – Alternative 1* on page 176
- *Heading offset – Alternative 2* on page 177
- *Sound speed quality inspection* on page 178
- *Sound speed control* on page 179
- *Verification* on page 180
- *How to determine calibration values using SIS Calibration frame* on page 181
- *How to determine calibration values using SeaCal automatic calibration* on page 184
- *How to collect the sound velocity profile* on page 141
- *How to convert your sound velocity profile to SIS format* on page 143
- *How to modify and load a sound speed profile into SIS* on page 151

Parameter references

- *Calibration parameters* on page 260

- *Seacal auto calibration* on page 261

Related topics

- *Keyboard and mouse in the Calibration view* on page 46
- *SeaCal* on page 409

The menu system

This chapter provides a brief description of the menu system provided by SIS. The menu options are not explained in detail, but references are provided for the detailed dialog box and functional description.

Main menu

The main menu is located on the top of the application window. It provides the following choices:

- *File menu* on page 104
- *View menu* on page 105
- *Tools menu* on page 105
- *Help menu* on page 107

File menu

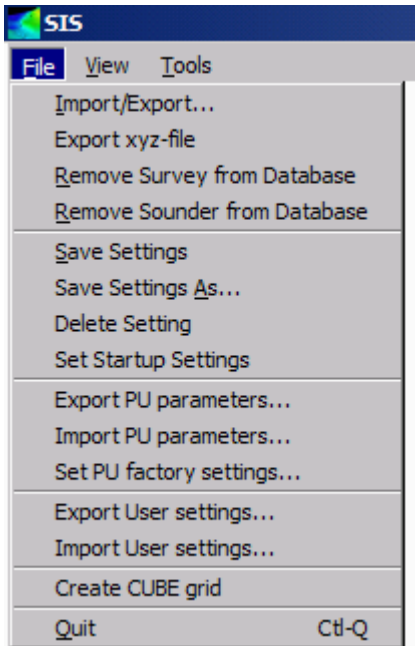

The **File** menu gives you the following choices:

- **Import/Export:** Dialog for import and export of raw data and gridded survey data
See *Import/Export* on page 352
- **Export xyz file:** Export of survey data to xyz ascii file
See *Export xyz file* on page 361
- **Remove survey from Database:** Used to delete surveys from the database
See *Remove survey* on page 362
- **Remove sounder from Database:** Used to delete obsolete or unwanted echo sounders from the database.
See *Remove sounder* on page 362
- **Save settings:** Used to save current frame settings
See *Save settings* on page 363
- **Save settings as...:** Save current frame settings with a new filename
See *Save settings as...* on page 363
- **Delete settings:** Used to delete selected frame setting file
See *Delete settings* on page 364
- **Set startup settings:** Used to select how you want the SIS frames to appear at start up
See *Set startup settings* on page 364
- **Export PU parameters:** Used to save the Installation and Runtime parameters for current echo sounder to file in an ascii readable format
See *Export PU parameters...* on page 364
- **Import PU parameters:** Used to import previously saved parameters for a given echo sounder
See *Import PU parameters...* on page 366
- **Set PU factory settings:** Used to restore the echo sounder's (PU's) original factory settings.
See *Set PU factory settings...* on page 367
- **Export user settings:** Used to save current database settings for later retrieval
See *Export user settings...* on page 368
- **Import user settings:** Import previously exported database settings
See *Import user settings...* on page 369
- **Create CUBE grid:** Used to create a CUBE grid after completion of data logging
See *Create CUBE grid* on page 369
- **Quit:** Exit SIS

See *Quit* on page 370

View menu

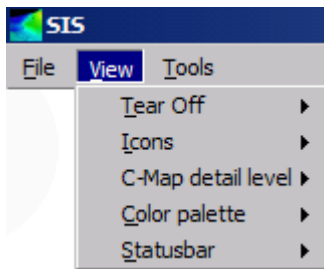

The **View** drop-down menu gives you the following choices:

- *Tear-off windows* on page 39
- *Icons* on page 40
- *C-MAP detail level* on page 41
- *Colour palette* on page 41
- *Status bar* on page 42

Tools menu

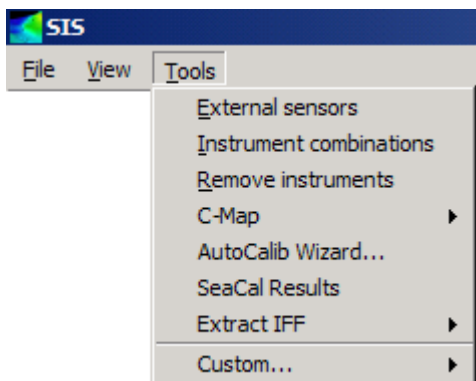

The **Tools** drop-down menu gives you the following choices:

- **External sensors:** This is where you define the interfaces to your external sensors that are attached directly to the Hydrographic Work Station (HWS)
See *External sensors* on page 371
- **Instrument combination:** This is a dialog for creating combined interfaces from external sensors that can be started as any system sent from the PU

See *Instrument combinations* on page 377

- **Remove instruments:** Used to remove selected instrument combinations.
See *Remove instruments* on page 378
- **C-MAP:** Dialog for administrative for C-MAP – only available if C-MAP is installed
See *C-MAP – Licence administration* on page 379
- **AutoCalib Wizard:** Wizard that will guide you through a SeaCal calibration
See *AutoCalib Wizard* on page 380
- **SeaCal results:** Direct access to location where your Seacal result files are stored
See *SeaCal results* on page 381
- **Extract IFF:** Used to extract position datagrams
See *Extract IFF* on page 381
- **Custom...:** A new level of menu selections.
See *Custom menu* on page 106

Custom menu

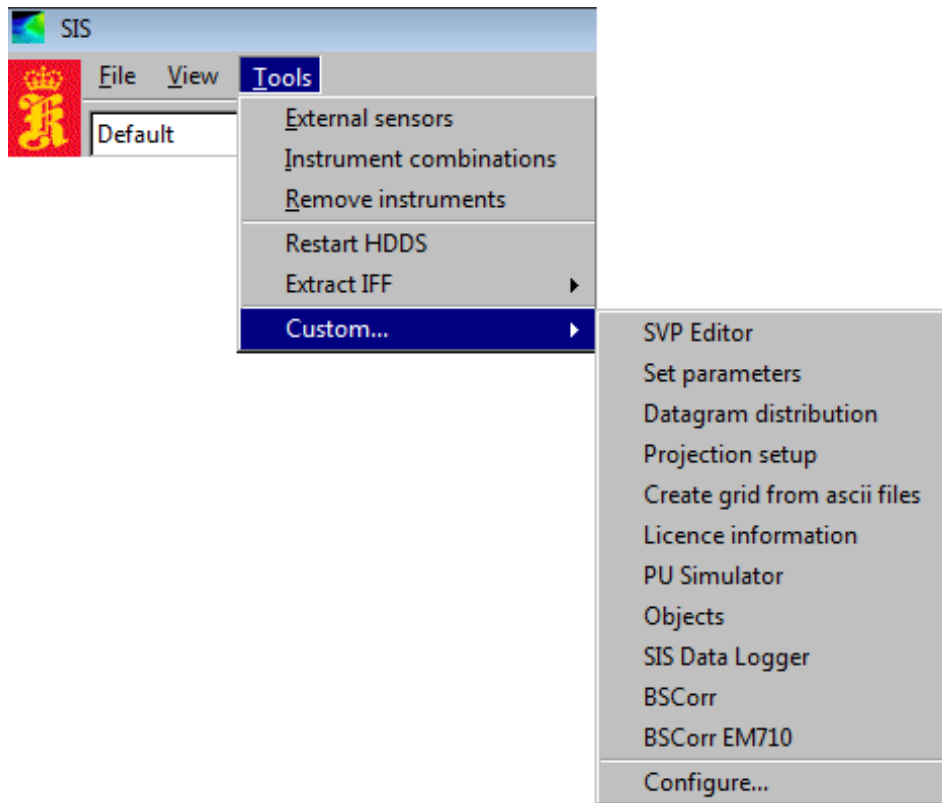

The **Custom...** sub-menu is accessed from the **Tools** menu. This menu is used to access various Custom applications. It is also possible to manage or add applications to this menu.

Choose between the following options:

- **SVP editor:** Used to load and edit sound speed profiles logged in .asvp or .actd format.
See *SVP Editor* on page 395
- **Set parameters:** Parameter settings that are used to control the behaviour of SIS.
See *SIS parameters – Set parameters* on page 333
- **Datagram distribution:** Used to route selected datagrams to given IP addresses on the network.
See *Request datagrams from an echo sounder* on page 559
- **Projection setup:** Used to define the projections and datum transformation that you later can apply.
See *Projection and datum parameters* on page 384
- **Create grid from ASCII files:** Dialog for creating terrain model from a Neptune ASCII file.
See *Create grid from ASCII files* on page 451
- **Licence information:** Opens the log file to the license server, containing your SIS license information.
- **PU Simulator:** Used for simulation and playback of previously logged raw data.

See *PU simulator and playback* on page 449

- **Objects:** Opens a utility for adding points, lines, images, text, polygons, video and html into the SIS map.

See *SIS Objects* on page 417

- **SIS data logger:** Opens a utility for logging data received on either the PU or the SIS computer.

See *Logging utilities* on page 435

- **BSCorr:** Opens a utility program for editing the backscatter calibration. When completed the backscatter calibration file is returned to the PU for use. Applicable for EM 122 and EM 302.

- **BSCorr EM710:** Opens a utility program for editing the backscatter calibration for EM 710. When completed the backscatter calibration file is returned to the PU for use. Applicable for EM 710.

- **Configure...:** Used to manage existing applications in the **Custom** sub-menu.

See *Configure...* on page 382

Help menu

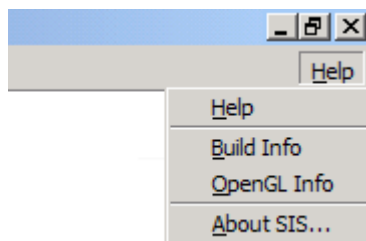

The **Help** drop-down menu gives you the following choices:

- **Help:** Opens online help
See *Help* on page 391
- **Build info:** Contains information about your SIS software build.
See *Build info* on page 391
- **OpenGL settings:** Contains information related to SIS software drivers.
See *OpenGL settings* on page 392
- **About SIS:** General SIS software information.
See *About SIS...* on page 392

Operational procedures

This chapter presents the most important operational procedures required to operate the SIS software.

You will find descriptions and main operational procedures on how to start and exit SIS, plan and run a survey, set installation and runtime parameters etc. in this chapter.

Note

This chapter applies to all the Kongsberg Maritime multibeam echo sounders. You may therefore find that some procedures and parameter settings do not apply to your EM 2040 system.

For parameter description specific to your system we refer you to the Parameter references on page 209.

The following operational procedures are described in this section:

Start, stop and operational procedures

- *Normal operational sequence on page 111*
- *How to start SIS on page 112*
- *How to start pinging on page 160*
- *How to start the Remote Helmsman Display on page 206*
- *How to import a Neptune grid to SIS on page 159*
- *How to start the echo sounder on page 154*
- *Detecting the echo sounder on the network on page 158*
- *How to interface a singlebeam echo sounder in SIS on page 156*
- *How to start and stop logging – Alternative 1 on page 169*
- *How to start and stop logging – Alternative 2 on page 169*
- *How to save data on page 169*
- *How to log water column data on page 170*
- *How to log stave data on page 170*
- *How to export survey results after a survey on page 207*
- *How to exit the SIS software on page 207*
- *How to shut down the HWS on page 208*

- *How to shut down the Processor Unit (PU) or the Transceiver Unit on page 208*

Configuration procedures

- *How to configure your survey on page 113*
- *How to enter parameters for a new survey on page 118*
- *How to enter survey parameters on page 114*
- *How to define a new projection and datum transformation on page 122*
- *How to setup the input from external sensors on page 137*
- *How to setup the output to external sensors on page 139*
- *How to enter the waterline for a single beam system on page 139*
- *How to open the installation parameter interface on page 127*
- *How to modify the installation parameters on page 127*
- *How to open the runtime parameter interface on page 134*
- *How to modify the runtime parameters on page 134*
- *How to collect the sound velocity profile on page 141*
- *How to convert your sound velocity profile to SIS format on page 143*
- *How to modify and load a sound speed profile into SIS on page 151*
- *How to automatically collect and apply a sound velocity profile in SIS on page 152*

Quality control procedures

- *How to monitor the external sensors in SIS on page 160*
- *How to monitor the survey progress on page 202*
- *How to verify data logging on page 170*
- *How to display realtime depths on page 161*
- *How to verify echo sounder main functions on page 162*
- *How to display a smooth surface on page 165*
- *How to look for artifacts on page 165*
- *How to display seabed imagery data in the Geographical view on page 162*
- *How to display sound velocity at transducer depth in the Geographical view on page 163*
- *How to create and use a GeoTIFF background image in the Geographical view on page 166*

Calibration procedures

- *Roll offset in the across-track direction on page 173*
- *Pitch offset and time delay on page 174*
- *Heading offset – Alternative 1 on page 176*
- *Heading offset – Alternative 2 on page 177*
- *Sound speed quality inspection on page 178*
- *Sound speed control on page 179*

- *Outer beam angle offset calibration* on page 180
- *Verification* on page 180
- *How to determine calibration values using SIS Calibration frame* on page 181
- *How to determine calibration values using SeaCal automatic calibration* on page 184
- *How to calibrate a dual head system* on page 188

Planning procedures

- *How to plan a new job in SIS* on page 201
- *How to retrieve a planned job* on page 202
- *How to display planned lines on the Remote Helmsman Display* on page 206

SIS utilities

Operational procedures describing various functionality of the SIS utilities are found in section *SIS utilities* on page 394. The following operational procedures are described:

- *How to use SmartTalk* on page 142
- *How to use csv2asvp* on page 143
- *How to use SVP Logger* on page 144
- *How to use SVP Manager* on page 145
- *How to use SVP Editor to convert an SVP file to .asvp format* on page 147
- *How to use macros in the SVP Editor to convert an SVP file to .asvp format* on page 149
- *How to run the PU simulator* on page 203
- *How to change the language of SIS* on page 112
- *Raypaths chart* on page 401
- *How to use SIS Objects* on page 417
- *How to convert S-57 chart files to SIS input data* on page 458
- *How to do Precise Point Positioning in SIS* on page 478

Normal operational sequence

Note

*To ensure correct setup and operation of SIS the **Survey Template Handling** is essential. When all parameters are set up and stored in the template, all future surveys that are set to using this template will be defined by these parameters.*

Note

If SIS has been left inactive for some time, the operating system may have swapped the complete SIS process to disk. The operating system must then read SIS into the RAM again. This may take a few seconds. Datagrams including installation and runtime parameters must not be sent to the Processing Unit during this process.

Normal operational sequence

The normal sequence of operations required for running surveys using SIS are as follows:

- 1** Start SIS
See *Start SIS* on page 112
- 2** Enter survey and operator parameters, background data and set projection
See *Enter survey and operator parameters, set projection* on page 113
- 3** Check installation and runtime parameters
See *Check installation and runtime parameters* on page 125
- 4** Start the echo sounder
See *Start the echo sounder* on page 154
- 5** Run the Built-In Self Tests (recommended)
See *BIST* on page 133
- 6** Import a Neptune grid (optional)
See *Import a Neptune grid to SIS* on page 159
- 7** Start pinging
See *Start pinging* on page 160
- 8** Check sensor input
See *Check sensor input* on page 160
- 9** Check echo sounder main functions
See *Check echo sounder main functions* on page 161
- 10** Start and stop logging
See *Start and stop logging* on page 169
- 11** Perform a system calibration (optional)
See *Perform a system calibration* on page 171
- 12** Plan a survey (optional)
See *Plan a survey* on page 199
- 13** Run the survey
See *Run the survey* on page 202
- 14** Export data
See *Export data* on page 206
- 15** Operate Helmsman Display (optional)
See *Remote Helmsman Display* on page 206

16 Exit SIS

See *Exit SIS* on page 207

Start SIS

How to start SIS

Note

The SIS license dongle must be connected to an USB port on the HWS. The license dongle is required to run the advanced options of SIS.

- 1 Power up the echo sounder units.
- 2 Power up the external sensors.

Note

Your system may include a number of peripheral devices. Consult the applicable manufacturer's documentation for correct operation of these.

- 3 Configure the single beam echo sounder(s) - if applicable.
- 4 Power up the SIS HWS – Hydrographic Work Station.
The operating system on the SIS HWS loads automatically. When the boot process is finished, you can open the SIS program.
- 5 Click on the SIS icon on the desktop or select SIS from the Windows start menu.
- 6 Verify that the SIS application window opens as described in *The application window* on page 25.

How to change the language of SIS

Normally, you will set your language of SIS during software installation. It is also possible to change the language. This is done from a command window outside SIS.

Note

The translations from English may be incomplete.

- 1 Open a console window, e.g. as follows
 - a Press the Windows **Start** button
 - b Select **Run...** in the right side of the Start menu
 - c Type **cmd** in the text field that appears
 - d Press **OK**
- 2 Go to the directory where the **SIS\SQL** directory.
To change drive and directory in a console window:
 - a Type the drive letter, e.g. **C:**, and press Enter to change the drive

- b** Type `cd\` to change directory to the root directory
- c** Type `cd <sub-folder> \<next sub-folder>` to change the directory to an existing directory below, e.g. `cd program files\Kongsberg Maritime\SIS\sql` to change to the SIS\SQL directory
- 3** Type `setParameter SIMRAD_LANG 1 <number>`, where `<number>` is:
 - 1** = Norwegian
 - 2** = English
 - 3** = Spanish
- 4** Press the **Enter** button on the keyboard.

Enter survey and operator parameters, set projection

We recommend that you define one or several survey templates for the survey area before you start the survey.

How to configure your survey

- 1** Choose the frame **Survey Administration** and set the parameters for your survey type. These settings can be stored as a survey template available for easy set up of new surveys.
- 2** Select the frame **New survey** and select applicable survey template from here
- 3** Define the **survey name**
- 4** Check and verify reasonable **grid cell size**

The parameters can be saved to current or all survey templates, and it is thereby not required to set these parameters more than once for a survey. This method will save you a lot of work, and ensure correct survey parameter setup throughout the survey.

This section explains how to create and modify survey templates.

Operational procedures

- *How to enter survey parameters* on page 114
- *How to enter parameters for a new survey* on page 118
- *How to define a new projection and datum transformation* on page 122

The parameter settings are not explained in details in this section. Please refer to the following sections for a complete description of the parameters:

Parameter references

- *Survey parameters* on page 263
- *Basic parameters* on page 263
- *Storage options* on page 265
- *Background data* on page 267

- *Projection parameters* on page 269
- *GridEngine parameters* on page 269
- *User handling* on page 272
- *CUBE parameters* on page 273
- *Data cleaning* on page 317
- *Projection and datum parameters* on page 384

Related topics

- *New survey window* on page 89
- *Survey administration window* on page 91

Set survey parameters

How to enter survey parameters

Open the **Survey administration** frame, select the different tabs in turn and enter parameters as described in the following.

User handling

This is where you add new users of SIS.

- 1 Enter identification a the new user
- 2 Press **Update** to apply

Background data

Background data in SIS are any projection file, KSGPL contour files, files containing predicted tide or geoid data files that you want to apply.

If you have background data, you can enable (or disable) the files for your survey or survey template by selecting the path to where the files are stored.

- 1 Select the path to the background data.
- 2 Press the **Add** button to add that file location to the list of background data and/or
- 3 Select the background data path to be remove
- 4 Press **Delete** to remove the files from SIS.
The files are not deleted from the disk.

Survey template handling

The **Survey template handling** tab is used for creating survey templates or modifying existing survey templates.

The survey templates are useful for easy and correct setup of the survey parameters of SIS. Once a setup for a survey is done the complete setup can be stored in a template and used for next survey at the same place, for next survey with similar setup or just as a template for correct setup of a new template.

1 Select the **Basic parameters** tab.

- a** Enter a new name in the **New survey template** text field if you want to create a new template,
or
select the template you want to modify from the **New survey template** drop down list.
- b** Select the **Survey template** you want your new template to be based upon from the drop down list.
You can select any of previously stored templates, previous used template or default template.
- c** Select name of user.
If you want a new user to be defined go to the **User handling** tab.
- d** It may be useful to add your own comments **Comment** to the generated template.
- e** Press **Update** to save the new template or the modifications you have done to an existing template.

Note _____

*If you do any further changes to the survey template you have defined, you must remember to press the **Update** button again to save your changes.*

_____**2** Select the **Storage options** tab.

Observe the default storage location of raw data and gridded (survey) data. We recommend that you stick to the default storage structure unless you have specific requirements. Sub-directories will be added according to your selections of naming convention as described in point 4 below.

- a** Select where you want gridded data to be stored.
- b** Select where you want your raw data to be stored.
- c** Select the naming convention of your raw data by selecting appropriate tick boxes.
For each tick box you enable a new sub-directory for storage of **raw** data is added.
- d** Enter name of the ship, and tick off for **Use as postfix in filename** if you want the ship's name as the last part of the file names.
- e** Click **Apply to all survey templates** if you want your settings to apply to all loaded templates.

Survey template handling – Advanced options

This tab is found both under the **Survey administration** frame and in the **New survey** frame. Modifications that you do from the **Survey administration** frame applies to the template you are working on, whilst if you do modifications from the **New survey** frame they will only apply to current survey.

Note

*Independent of where you are accessing these pages from, you will find **Apply** buttons that are short-cuts to applying your changes to either **all survey templates** or to the **default survey template**.*

The **Advanced options** tab contains four new tabs. The configuration of all are described in the following procedure.

1 Select the **Background data** tab.

This is where you select the file location of background data that you want to use for the survey template you currently are setting up. You can choose between paths that were enabled in the **Background data** tab at the top level of the **Survey administration** window.

The background data may be a projection file, a KSGPL contour file, a file containing predicted tide or a geoid data file.

Click **Apply this path to the Default survey** only if you want your selection of background data to apply to the **Default** template.

2 Select the **Projections** tab.

Select your projection from the drop-down list.

If your datum and projection is not in the list a new datum and projection can be defined from **Tools**→**Custom**→**Projection setup**.

Click **Apply this projection to the survey template** only if you want your changed projection to be the default projection in the **Default** template.

3 Select the **GridEngine parameters** tab.

a If you are applying real time data cleaning, select what depth to use in the processing.

The real time data cleaning module will use the given depth plane to identify outliers in the data and remove them.

Note

We recommend that you set the real time data processing depth to either tide corrected depth, Z_t , or to geoid and RTK corrected depth, Z_v , in order to avoid unwanted depth rejections caused by natural variations such as the tide.

b Select resolution of your grid, i.e. number of cells and cell size, suitable for your depth and expected coverage.

Note

The grid resolution applies to displayed data only, the raw data is not affected.

The grid resolution can not be changed during the survey, and should therefore be carefully set to apply to the whole survey area.

If the cell size is set too large the resolution in your geographical view will be poorer than necessary. If you set the cell size too small you may experience

that there are not sufficient data points in the cells to compute a valid depth value, and no depth value is displayed. Too small cell size may also overload the computer and give you delays in the real time display.

The following factors have influence on the selection of the cell number and cell size:

- Depth
- Achieved swath width (shown in numerical display)
- Survey speed
- Coverage area per beam (footprint)

The following rule of thumb have proven to be reasonable:

Normal resolution

- Cell size = average swath width/100
- Number of cells in processing grids: 64x64

High resolution

- Cell size = average swath width/200
- Number of cells in processing grids: 128x128

Example: If depth is 100 meters and sector coverage is set to $\pm 70^\circ$, the swath width is 550 meters. Cell size computed from above rule of thumb for may then be set to 5.5 meters for normal resolution and 2.8 meters for high resolution.

Note

The cell size settings applies to highest possible display resolution, i.e. LOD0.

- c** If you want to do real time data cleaning, you may access the real time processing parameters by pressing the **Processing...** button.
- You will be directed to the **Real time data cleaning** page normally accessed from the **Runtime parameters** frame. The real time data cleaning uses rules, i.e. a set of parameters that controls the algorithms used in the real time processing of echo sounder data.
- By default, the real time data cleaning is set off.
- d** Click **Apply to all survey templates** if you want your GridEngine settings to apply to all loaded templates.

Cube parameters

This procedures applies only if you want to use the CUBE data cleaning method instead of the default GridEngine.

CUBE is enabled from **Tools**→**Custom**→**Set parameters**→**Logging**.

- 1 Select the depth reference you want to use
- 2 Enter the geographical coordinates of the centre of your survey area.
- 3 Enter the width and height of your survey area.

- 4 Enter your required grid cell size.

The smaller grid cell size the better resolution. However, too small grid cells will not be accepted by the CUBE algorithms. You may have to enter a larger grid cell size.

Note

*Remember to press the **Update** button from the **Basic parameters** tab to save your changes.*

Related operational procedures

- *How to enter parameters for a new survey* on page 118
- *How to define a new projection and datum transformation* on page 122

Parameter references

- *Survey parameters* on page 263
- *Basic parameters* on page 263
- *Storage options* on page 265
- *Background data* on page 267
- *Projection parameters* on page 269
- *GridEngine parameters* on page 269
- *User handling* on page 272
- *CUBE parameters* on page 273
- *Projection and datum parameters* on page 384
- *Data cleaning* on page 317
- *Logging* on page 341

Related topics

- *CUBE* on page 464
- *SIS architecture* on page 487

Start a new survey

How to enter parameters for a new survey

We assume at this stage that you have created a survey template that defines your survey parameters. The **New survey** frame is then used to define current survey, based upon parameters given by the survey template.

Open the **New survey** frame, select the different tabs in turn and enter parameters as suggested in the following.

Basic parameters

- 1 Select the **Basic parameters** tab.
- 2 Enter a unique survey name descriptive to your survey in the **New Survey name** text field.

- 3 Select the survey template you have defined for your survey in the **Select survey-template** drop down list.
The setup for previous survey was automatically saved as a template named **Previous**. If the conditions for your new survey are the same as for the previous one, select the **previous** to easily select correct survey parameters.
- 4 Select a predefined **User**.
If your user name is not defined you may add a user from the **User handling** tab in the **Survey administration** frame.
- 5 Select an existing survey if you want to continue data logging to an existing survey.
Press **Continue on existing survey** to confirm.
- 6 Add any comments that may give relevant information about the survey. The comment will be logged in the header of each raw data file.
- 7 After you have set ALL parameters, including the storage options and advanced options, press **Save new survey** to save and apply your settings.

Storage option

This tab is found both under the **Survey administration** frame and in the **New survey** frame. Modifications that you do from the **Survey administration** frame applies to the template you are working on, whilst if you do modifications from the **New survey** frame they will only apply to current survey.

Observe the default storage location of raw data and gridded (survey) data. We recommend that you stick to the default storage structure unless you have specific requirements. Sub-directories will be added according to your selections of naming convention as described in point 4 below.

If required,

- a Select where you want gridded data to be stored.
- b Select where you want your raw data to be stored.
- c Select the naming convention of your raw data by selecting appropriate tick boxes.
For each tick box you enable a new sub-directory for storage of **raw** data is added.
- d Enter name of the ship, and tick off for **Use as postfix in filename** if you want the ship's name as the last part of the file names.
- e Click **Apply to all survey templates** if you want your settings to apply to all loaded templates.

Survey template handling – Advanced options

This tab is found both under the **Survey administration** frame and in the **New survey** frame. Modifications that you do from the **Survey administration** frame applies to the template you are working on, whilst if you do modifications from the **New survey** frame they will only apply to current survey.

Note

*Independent of where you are accessing these pages from, you will find **Apply** buttons that are short-cuts to applying your changes to either **all survey templates** or to the **default survey template**.*

The **Advanced options** tab contains four new tabs. The configuration of all are described in the following procedure.

1 Select the **Background data** tab.

This is where you select the file location of background data that you want to use for the survey you currently are setting up. You can choose between paths that were enabled in the **Background data** tab at the top level of the **Survey administration** window.

The background data may be a projection file, a KSGPL contour file, a file containing predicted tide or a geoid data file.

Click **Apply this path to the Default survey** only if you want your selection of background data to apply to the **Default** template.

2 Select the **Projections** tab.

Select your projection from the drop-down list.

If your datum and projection is not in the list a new datum and projection can be defined from **Tools**→**Custom**→**Projection setup**.

Click **Apply this projection to the survey template** only if you want your changed projection to be the default projection in the **Default** template.

3 Select the **GridEngine parameters** tab.

a If you are applying real time data cleaning, select what depth to use in the processing.

The real time data cleaning module will use the given depth plane to identify outliers in the data and remove them.

Note

We recommend that you set the real time data processing depth to either tide corrected depth, Z_t , or to geoid and RTK corrected depth, Z_v , in order to avoid unwanted depth rejections caused by natural variations such as the tide.

b Select resolution of your grid, i.e. number of cells and cell size, suitable for your depth and expected coverage.

Note

The grid resolution applies to displayed data only, the raw data is not affected.

The grid resolution can not be changed during the survey, and should therefore be carefully set to apply to the whole survey area.

If the cell size is set too large the resolution in your geographical view will be poorer than necessary. If you set the cell size too small you may experience

that there are not sufficient data points in the cells to compute a valid depth value, and no depth value is displayed. Too small cell size may also overload the computer and give you delays in the real time display.

The following factors have influence on the selection of the cell number and cell size:

- Depth
- Achieved swath width (shown in numerical display)
- Survey speed
- Coverage area per beam (footprint)

The following rule of thumb have proven to be reasonable:

Normal resolution

- Cell size = average swath width/100
- Number of cells in processing grids: 64x64

High resolution

- Cell size = average swath width/200
- Number of cells in processing grids: 128x128

Example: If depth is 100 meters and sector coverage is set to $\pm 70^\circ$, the swath width is 550 meters. Cell size computed from above rule of thumb for may then be set to 5.5 meters for normal resolution and 2.8 meters for high resolution.

Note _____

The cell size settings applies to highest possible display resolution, i.e. LOD0.

- c** If you want to do real time data cleaning, you may access the real time processing parameters by pressing the **Processing...** button.
- You will be directed to the **Real time data cleaning** page normally accessed from the **Runtime parameters** frame. The real time data cleaning uses rules, i.e. a set of parameters that controls the algorithms used in the real time processing of echo sounder data.
- By default, the real time data cleaning is set off.
- d** Click **Apply to all survey templates** if you want your GridEngine settings to apply to all loaded templates.

Note _____

*Remember to press the **Save new survey** button from the **Basic parameters** tab to save your changes.*

Related operational procedures

- *How to define a new projection and datum transformation* on page 122
- *How to enter survey parameters* on page 114

Parameter references

- *Survey parameters* on page 263
- *Basic parameters* on page 263
- *Storage options* on page 265
- *Background data* on page 267
- *Projection parameters* on page 269
- *GridEngine parameters* on page 269
- *User handling* on page 272
- *CUBE parameters* on page 273
- *Projection and datum parameters* on page 384
- *Data cleaning* on page 317

Define a projection and datum transformation

How to define a new projection and datum transformation

- 1 Select **Tools**→**Custom**→**Projection setup** from the main menu.
- 2 Select the **Define projections** tab.
- 3 Locate the **Projection definition** section.
- 4 Press the **New** button.
- 5 Enter a name to identify the selected datum and projection, e.g. ED50_UTM30
- 6 Enter the type of projection for mapping the ellipsoidal coordinates onto the map plane

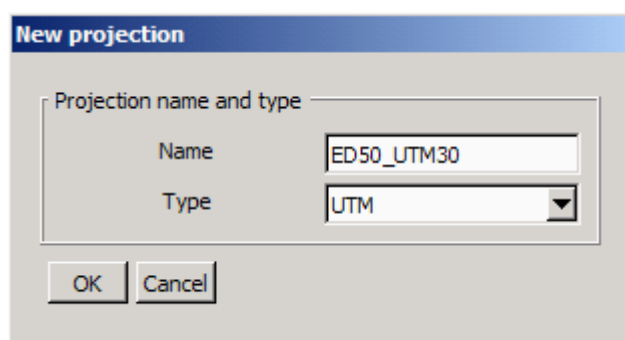

Press **OK** to continue

Datum information

Datum transformation

Datum transformation active

From ellipsoid: 01:WGS84 Choose ellipsoid

Rotation unit is RADIANS Select transformation

Scale: -1.200 Delete transformation

Rotation X: 0 Displacement X: 89.5

Rotation Y: 0 Displacement Y: 93.8

Rotation Z: 0.156 Displacement Z: 123.1

Information: WGS84 to ED50

Ellipsoid

Ellipsoid for projection: 1:WGS84 Choose ellipsoid

OK Cancel

- 7 Tick off for **Datum transformation active** if you want the entered datum transformation to be carried out to your input positions.
Datum transformation is by default turned off.
- 8 Press **Choose ellipsoid** to select the ellipsoid of the input position.
For GPS position input this will normally be the WGS84 ellipsoid.
- 9 Press **Select transformation** to use predefined datum transformation parameters
or
- 10 Enter the 7-parameter datum transformation parameters in the applicable parameter fields
- 11 Press **Choose Ellipsoid** in the **Ellipsoid** field to enter the ellipsoid for the output position.

Ellipsoid

Ellipsoid for projection: 05:intl Choose ellipsoid

12

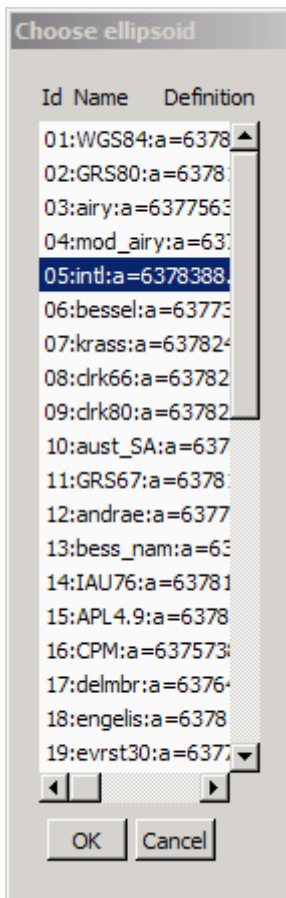

Select the ellipsoid and press **OK** to apply.

The available ellipsoids in SIS are identified by (scroll the side bar to view the parameters):

- id
- short name
- major axis (a)
- reverse flattening (rf)
- full ellipsoid name

e.g. for ED50, the International 1909 ellipsoid applies having the following parameters:

- id = 05
- short name = intl
- a = 6378388.0 m
- rf = 297.0

13

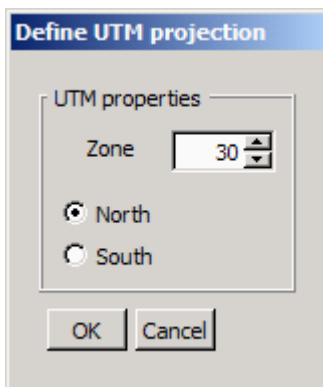

Press **OK** to apply the datum transformation selected.

When UTM projection type has been selected the **Define UTM projection** dialog will appear

- 14 Select **UTM zone** and whether you are on northern or southern hemisphere.
- 15 Press **OK** to apply.
- 16 Press **Edit...** to change the datum transformation or projection parameters selected
- 17 Press **Delete...** if you want to delete the settings

you have chosen

Parameter references

- *Projection and datum parameters* on page 384

Related topics

- *Available projections in SIS* on page 387

Check installation and runtime parameters

Installation and runtime parameters are associated with the echo sounder and not with the survey. This means that the installation and runtime parameters are set up separately for each individual echo sounder. These parameter settings will remain the same for that echo sounder, independent of the survey run.

The parameter settings for each echo sounder will be stored in a database. When an echo sounder is detected for the first time, all parameters will be set to a default value, determined by the type of echo sounder. It is important that the installation and runtime parameters are checked and updated if necessary.

Note

We recommend that you keep a record of the parameters and settings used in a safe and accessible place.

External sensors: For interfaces to external sensors that are attached directly to the Hydrographic Work Station (HWS) the interface parameters must be defined in the External sensors dialog.

Note

The Installation parameter window can be displayed at any time, but parameters can only be modified when pinging and logging is deactivated.

The Runtime parameter window can be modified at any time, independent of pinging and logging status.

Operational procedures

- *How to open the installation parameter interface on page 127*
- *How to modify the installation parameters on page 127*
- *How to open the runtime parameter interface on page 134*
- *How to modify the runtime parameters on page 134*
- *How to setup the input from external sensors on page 137*
- *How to setup the output to external sensors on page 139*
- *How to enter the waterline for a single beam system on page 139*

Parameter references

- *Installation parameters on page 274*
- *Runtime parameters on page 297*
- *External sensors on page 371*

Related topics

- *Installation parameters window on page 94*
- *Runtime parameters window on page 95*

Installation parameters

The installation parameters are divided into three main groups described in the following:

- Communication setup parameters
- Sensor setup parameters
- BIST – self test

Note

*The **PU – Processing Unit** may be a separate hardware unit or an integrated part of the **TRU – Transceiver Unit** cabinet, depending on echo sounder system.*

For SIS it makes no difference whether the communication is with a PU or a PU inside a TRU. The term PU is used in this manual.

Communication setup parameters

The communication setup parameters define the input and output settings for the serial - and network (Ethernet) ports on the echo sounder Processing Unit. In addition, this parameter group defines the type of information (datagrams) that is received and/or sent on the individual ports. To be able to set these parameters correctly it is necessary to know the type of equipment connected to each individual PU port. Depending on the port type, the connections are either direct using a serial link, or remote via the system network. The equipment type and which port the different equipment types may be connected to, is defined by a set of rules/restrictions. These rules are defined in the **PU communication**→**Input setup** tab located in the **Installation parameter** frame.

Note

If the communication setup is not correct this may result in loss or corrupted functionality - in worst case an inoperable system.

Sensor setup parameters

In order to determine correct depth values the system must know the physical positions, tilt, biases and delays for all transducers and sensors. This information belongs in the second main group of installation parameters - sensor setup parameters. Also, based on the set of equipment that is connected to the echo sounder PU (Processing Unit), it may be necessary to select what equipment to use as active units when several alternatives are available. If no selection is made, the system will automatically use the sensor connected to the lowest numbered port when two or more alternatives are available.

BIST - self tests

The options available allow you to test individual functions and hardware items.

How to open the installation parameter interface

The installation parameters for the different echo sounders are located in the **Installation parameter** window. All external sensors connected to the Hydrographic Work Station (HWS) are located in the **External sensors** dialogue box found on the **Tools** drop-down menu.

In order to open the installation parameter interface perform the following actions:

- 1 If you have more than one echo sounder connected, select the echo sounder you want to change parameters for in the **Current echo sounder** combo box.
- 2 Select the Installation parameters by either:
 - Use the **Frame selection** button to select Installation parameters in the desired frame.or
 - Select **Installation parameters** from the **View→Tear Off** menu.

How to modify the installation parameters

Open the **Installation parameters** frame, select the different tabs in turn and enter parameters according to the recommendations below.

PU communication setup

This is where you define input to and output from the Processing Unit (PU).

Note

The PU – Processing Unit may be a separate hardware unit or an integrated part of the TRU – Transceiver Unit cabinet, depending on echo sounder system.

For SIS it makes no difference whether the communication is with a PU or a PU inside a TRU. The term PU is used in this manual.

- 1 Select the **Input Setup** tab.
 - a Set the communication settings for each of the ports you are using for input to the PU.

Select the port you want to modify first. Then baud rate, data bits, stop bits and parity must be set equal to the settings in the external sensor the port is connected to.

Note

- *COM1 – position input*
 - *COM2 – motion sensor input*
 - *COM3 – position input*
 - *COM4 – position input*
 - *UDP2 – position and depth input*
 - *UDP5 – attitude velocity input*
-

- b** Select the **Input format** of the data you want to read on the selected port, i.e. select the format your external device is set up to output.
- c** Select Port **UDP5** if you want to enable input of attitude velocity.
- d** Select if you want to use the secondary network for the attitude velocity data.
- e** Select what attitude sensor to read velocity data from.

You have to configure the PU's secondary network card. Find the net mask and a vacant IP address in the network you are connecting to. Enter your selected IP address and correct net mask. Set the port number to which the attitude system is transmitting to. Refer to the attitude system user's documentation if necessary.

2 Select the **Output Setup** tab to define the datagrams to be output from the Processing Unit (PU)

- a** Set the UDP Host port to either **SIS Logging** or **User defined** depending on what type of data you want to configure your output for.

- **SIS Logging** is used by the system to define what SIS raw data to log. The settings for this link should normally not be changed. Mandatory datagrams are disabled from deselecting

- **User defined** can be used when you need to define your own selection of datagrams. By using the given port address these datagrams can be picked up by any third party systems with access to the same network.

- **PU Logging** applies to systems where internal logging to PU disk is possible, e.g. when the PU is installed in an AUV.

Must be enabled by ticking off the **Enable PU logging to disk** check box below.

- **Watercolumn** can be selected if you want to log **Watercolumn** data to a separate file.

Must be enabled by ticking off the **Log watercolumn to separate file** check box below.

Port addresses is given by SIS and can not be changed.

- b** Select the datagram subscriptions for each output

We recommend:

- **SIS Logging**: Use the default setup.

- **User defined**: Subscribe to datagrams required by the receiving system.

- **PU Logging**: Use the default setup.

- **Watercolumn**: Subscribe to at least the Installation and Position datagrams.

- c** Select if you want the PU to broadcast it's existence on the network on given port.

3 Select the **Clock Setup** tab

- a** Select the time reference to synchronize the PU clock to.

The PU clock can be synchronized to either of the following time references:

- **External ZDA Clock**: An NMEA time datagram available from many GPS receivers. Outputs current UTC time which the PU clock will be set to.

Note

External ZDA can only be selected if ZDA input is selected. See PU communication – Input setup on page 275.

*When **External ZDA clock** is selected both the PU Communication Setup and the Clock Setup tabulators are changed to red to indicate that you need to check current clock setup.*

The red tabulator setting is turned off when the OK or the CANCEL button is pressed

In the case that the ZDA Clock input is turned off and the clock source setting is External ZDA Clock the (fall back) clock source is automatically set to Active pos. system.

- **Active pos. system:** The PU clock will be set to the time contained in the position datagram, normally the NMEA GGA datagram. For modern GPS system the time of **Active pos. system** is equal to current UTC time, i.e. negligible processing delay.

Note

The GGA datagram contains no date entry.

- **Operator station:** Sets the PU clock to the internal clock of the SIS Operator Station (HWS)
- b** **Offset (sec)** is used if you want to refer to a different time zone than your time reference. This may be useful e.g. if you have tide data referred to Local time, whereas you are synchronizing to UTC time.
- c** Select whether a 1PPS signal from a GPS receiver shall be used to synchronize the PU for clock drift.

If a 1PPS signal is available, it is highly recommended that you utilize it.

If possible, we recommend using **External ZDA Clock** and **1PPS** synchronization.

Related operational procedures

- *How to monitor the external sensors in SIS on page 160*
- *How to modify the runtime parameters on page 134*
- *How to log water column data on page 170*

Parameter references

- *PU communication – Input setup on page 275*
- *PU communication – Output setup on page 279*
- *PU communication – Clock setup on page 281*
- *Water column – Logging on page 247*
- *Water column – Show/hide on page 243*

Related topics

- *Timing* on page 498

Sensor setup

This is where you configure the input position and attitude sensors.

1 Select the **Settings** tab

- a Select what positioning system to modify by selecting its input port.

Only ports enabled for position input by the PU communication setup tab can be selected.

- b Select **Time to use**, i.e. what time tag to use for the position.

This can be

- **System** time, defined by the time tag given by the PU when the datagram arrives on the port
- or
- **Datagram** time, i.e. the time of the observation read from the position datagram

There are various scenarios:

- If the PU is synchronized to **External ZDA clock** and a **1PPS** signal is used, the position and depth will refer to the exact same time reference (UTC time). The PU software will know the exact time difference between the depth and the position observation, and correct for this.

Time to use is to be set to **Datagram** in this case. **Position delay** will not apply, and should be set to 0.

Note

Datagram is to be selected ONLY if the PU clock (Clock Setup tab) is set to External ZDA clock and 1PPS is connected and used.

This method is the recommended method for best possible time synchronization.

- If the PU is synchronized to **Active pos. system**, **Time to use** should be set to **System** and **Position delay** set to the processing time of your positioning system.

Note

For modern positioning system the position delay is normally negligible, but if the processing delay is significant you should consider choosing a different source for synchronization of the PU.

- If the PU is synchronized to the **Operator station**, **Time to use** should be set to **System**, and **Position delay** according to the processing time of your positioning system.

Note

*Independent of what method you use, you must monitor the PU time versus either the position time (PU-POS) or the ZDA (PU-ZDA) time in the **Numerical display**. Any large figures indicates synchronization errors, and should be corrected for.*

*Also note that the **Time to use** and **Position delay** settings can be changed during post processing.*

c Tick off for **motion correction** of your position input for.

d Enter a **position delay**.

You must refer to the position system's documentation to find the delay.

Delay will only apply if **Time to use** is set to **System**.

e Select name of the datum you are using.

Note

*This is only text information to the logged files. Actual datum is given by your position input. If required, datum transformation may be enabled from the **Tools**→**Custom**→**Projection setup** menu.*

f Select **Log all heights** if you want to enable height datagrams from the GGA and GGK position input with height input having a quality factor as specified.

g Enter the quality indicator numbers (comma separated) that you want to accepted as your height observations.

The quality indicators are given by the NMEA GGA and GGK specifications.

h Select the **roll reference plane** according to your motion sensor.

i Enter the motion sensor delay according to motion sensor documentation

j Select your active sensors by selecting the port to which the relevant sensor is connected

2 Select the **Location** tab

Enter the location offsets relative to the vessel reference point for the different sensors and transducers.

Caution

The positioning system may have internal offset parameters set. Make sure that the antenna offsets are not applied both in the positioning system and in SIS.

Note

If the vessel's displacement or trim changes during a survey, the waterline value must be updated accordingly.

3 Select the **Angular Offset** tab

Enter the angular offsets for the different sensors and transducers.

Caution

The attitude sensor may have internal offset parameters set. Make sure that the angular offsets are not applied both in the attitude sensor and in SIS.

- 4 Select the **ROV specific** tab if your system is mounted on an ROV/AUV.

Note

*ROV depth found in the **PU communication setup**→**Input setup** tab must have been selected to enable the ROV specific options.*

Verify that the depth and pressure settings are set according to your conditions.

Related operational procedures

- *How to monitor the external sensors in SIS on page 160*
- *How to define a new projection and datum transformation on page 122*
- *How to determine calibration values using SIS Calibration frame on page 181*
- *How to determine calibration values using SeaCal automatic calibration on page 184*

Parameter references

- *Sensor setup – Settings on page 283*
- *Sensor setup – Location for EM 2040 on page 288*
- *Angular Offsets for EM 2040 on page 290*
- *ROV Specific for EM 2040 on page 291*
- *PU communication – Input setup on page 275*

System parameters

- 1 Select the **System Parameters** tab
- 2 Verify that the backscatter offset parameters and the Tx and Rx opening angles are set as intended.

Note

The reference point of the array remains unchanged when the opening angle is changed. This means that you do not have to change the TX/RX location offsets after modification to the TX/RX opening angle.

Note

If the specified angles are set larger than the angles given by the physical array size, the system will run with degraded performance.

Example: If RX and TX opening angles are both set to 2 degrees for a 1 x 1 degree system, the system will run as a 2 x 2 degrees system, utilizing only parts of the transducer arrays.

Parameter references

- *System parameters for EM 2040* on page 292

BIST

The **BIST** page gives you access to run the different Built-In Self Tests that you can perform to check the operation of the echo sounder system.

- 1 Press the **Run all BISTs** button

or

Press each BIST test button one by one

- 2 Verify that all BIST test buttons turns green when test i performed.

If any of the tests fails the specific test button will turn red or yellow, and a description of the test result will be displayed in the **PU BIST result** field.

Please refer to the echo sounder's maintenance manual for corrective actions.

Parameter references

- *BIST – Built-In Self Test* on page 293

Runtime parameters

Runtime parameters are divided into the following main groups:

- Sounder Main parameters
- Sound Speed
- Filter and Gains
- Data Cleaning
- GPS and delayed heave
- Simulator
- Survey information

The content of these groups will vary depending on echo sounder type.

Sounder main

The sounder main settings concern the operational parameters for the echo sounder including coverage, depth and swath control.

Sound speed

Sound speed settings concerns selection and use of sound speed profiles and sound speed at transducer settings.

Filter and gains

Filter and gains settings concern filtering to avoid erroneous measurements, e.g. false bottom detection. It also includes settings for the bottom backscatter measurement and seabed imaging.

Data Cleaning and Seabed Image Processing

Data Cleaning defines rule sets for how the to carry out the gridding. There are two parameter groups: Ping processing rules and Grid processing rules. It also includes settings for the seabed imaging for the Geographical view.

GPS and delayed heave

The GPS and Delayed Heave tab contains options for logging of data files related to position and attitude data that optionally can be used in post processing to improve the final seabed data.

Simulator

The Simulator tab contains parameters for enabling simulation of echo sounder data.

Survey information

The Survey Information tab contains summarized information about current survey.

Advanced parameters

This menu is intended for Kongsberg Maritime internal use only. Pulse length and bandwidth can be changed from here.

How to open the runtime parameter interface

To open the runtime parameter interface the following actions must be carried out:

- 1 Select the echo sounder you want to change parameters for in the **Current echo sounder** combo box.
- 2 Select the Runtime parameters by either:
 - Use the **Frame** button to select Runtime parameters in the desired frame.or
 - Select **Runtime parameters** from the **View→Tear Off** menu.

How to modify the runtime parameters

Open the **Runtime parameters** frame, select the different tabs in turn and enter parameters according to the recommendations below.

Sounder main

- 1 Set the sector coverage parameters according to your conditions and requirements
- 2 Set the depth parameters according to your expected survey depth

Note

*The Min and Max depth settings are used to guide the echo sounder in tracking the bottom. Incorrect settings may result in a failure to detect the bottom and thus a disabled system. If the echo sounder has problems detecting the bottom within the min-max range use the **Force Depth** button with a measured depth or a depth from a chart.*

- 3 Set the swath control parameters
- 4 Set Pitch and Yaw stabilization parameters
- 5 Select whether the echo sounder will receive trigger signals from an external device (e.g. K-Sync)

Parameter references

- *Sounder main for EM 2040* on page 297

Sound speed

In order to ensure accurate depth determination, you must know the sound speed profile in the survey area. The profile may change with both time and position in the survey area. It may therefore be necessary to determine the profile several times during a survey. The profile is stored as a file.

- 1 Collect a sound speed profile from surface to bottom and save the profile to file.
- 2 Select the **Sound Speed** tab
This tab contains Sound Speed Profile and Sound speed at transducer depth.
- 3 Find and select the correct **Sound Speed Profile** file by using the **Browse** button.
The text field will turn yellow.
- 4 Activate the profile by pressing the button marked **Use Sound Speed Profile**.
The text field will return to original colour when loaded.
- 5 Select the **Sound speed at transducer** source as one of the following:
 - 1 Manual – Sound speed value must be entered.
 - 2 Profile – A value from the sound speed profile is used (existing value or interpolated).
 - 3 Probe – If you have a sound velocity probe attached at transducer depth the values from the probe is used. The offset value must then be specified.

Related operational procedures

- *How to collect the sound velocity profile* on page 141
- *How to convert your sound velocity profile to SIS format* on page 143
- *How to modify and load a sound speed profile into SIS* on page 151
- *How to display sound velocity at transducer depth in the Geographical view* on page 163

Parameter references

- *Sound speed for EM 2040* on page 305

Filter and gains

- 1 Set the **Filtering parameters**.
We recommended to only change the filtering parameters from default settings if false bottom detections is very likely.
- 2 Set the **Absorption Coefficient** parameters.

A correct value for the absorption coefficient is important with respect to the validity of the bottom backscatter measurements.

On broadband sonar systems, like the EM 710, absorption coefficient matrixes are automatically calculated by SIS from sound speed profiles and salinity and CTD profiles.

Default salinity is 35 ppt. Correct the value if necessary.

3 Set the Normal Incident Sector.

Degrees from nadir defines the angle at which the bottom backscatter can be assumed to be independent of the strong increase at normal incidence. The value is dependent on bottom type.

4 Set Mammal protection for system where this is implemented.

Reduced TX power level can be set, as well as a delay period in which the output power level gradually will be increase from zero up to set maximum level.

Parameter references

- *Filter and gains for EM 2040* on page 310

Data cleaning

This is where criteria for real time data cleaning are defined.

Caution

Please familiarize yourself with the SIS data cleaning functionality before making any changes to it's parameters.

Note

Real time data cleaning does not delete any data, invalid data is simply flagged.

Parameter references

- *Data cleaning* on page 317

External sensors

The **External sensors** page is accessed from the **Tools** menu, and are used to define interfaces to external sensors that are attached directly to the Hydrographic Work Station (HWS).

Note

*Interfaces to external sensors that are attached to the Processing Unit (PU) are defined in the **Installation parameters**.*

The External sensors dialog contain setup information for the following sensors:

Input

- Sound velocity probe

- Real time tide
- SVP logger
- Barometer
- Geodimeter
- Heading
- Position

Output

- Auto pilot
- Dynamic positioning
- Depth below keel

How to setup the input from external sensors

- 1 Enter the sound velocity probe parameters

Sound velocity probe

To prepare and use an external sound velocity sensor the following steps must be followed:

- a Make sure that the external sensor is powered up and connected to a HWS input port (i.e. COM port).

Alternatively, in the case where SIS is receiving external sound velocity datagrams via UDP the datagrams must be available on the network.

- b Select the type of sensor or input to use as source for the sound velocity samples:
 - a Tick the **Probe available** box to signify that a sound velocity sensor or external sound velocity datagrams is to be used.

The **Probe type** combo box is now enabled

- b Select the specific type of sound velocity probe to be used.

A number of choices are available:

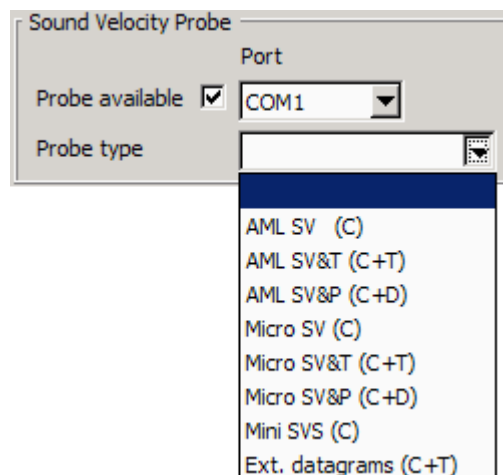

- c If a sensors is selected, set the port to where it is connected.

Note

There is no need to set communication settings for the selected input COM ports. (Auto detect or fixed 9600 baud is assumed).

If 'Ext. datagrams' is selected the port combo box is disabled as UDP is used.

- c Configure the **Sound speed** parameters in the **Runtime parameters**.
- 2 Tick off if you have input from either of the following sensors
- Realtime tide
 - SVP Logger
 - Barometer
 - Geodimeter
- 3 Set the port number, baud rate, data bits, stop bits and parity for each input enabled.

4 Enter the **Heading and position parameters**

This setting applies only if you are using SIS without any EM input, that is, if your position and heading are input directly to the SIS HWS, and not to the PU. This may be the case if you have single beam echo sounder input via NMEA datagrams and no multibeam echo sounder, or if you want to use SIS without any echo sounder input at all.

- a Write a name in the **Sensor name** combo box.

The name given here will be the one that is displayed in the installation parameters for GPS and single beam echo sounders.

- b Choose either **serial line** or **ethernet** connection. Press **Add** for each sensor.
 - If you choose a serial port, mark the check box under **Serial** and select the port you want to use for heading and/or position by selecting it from the combo boxes under **Port**. The communication parameter is set with the respectively combo box.
 - If you want to use an Ethernet connection, mark the check box under **Ethernet**. The IP address and the port, where the data is to be send, is displayed in the text field to the right.
 - If serial line communication is chosen a small program starts automatically when the equipment is started. This program receives data on RS-232 and forwards the data on UDP. The program will close down automatically.

- c **Compass deviation file:** Use the browse button (three dots) to find the desired file.

- d **Position delay (sec):** Enter any known position delay.

The accuracy of the position sensor is vital for the data accuracy, and it is therefore important that the relative timing of vessel position data and system depth data is correct. To define the duration of life of the positioning system input data, you can enter a position delay.

A position delay is required if the position that is output on the port applies to an observation that was done a significant number of seconds ago. The

position delay may be significant for systems where the internal computation and processing of the position takes time.

- e **Location offset (m):** Use the text fields to enter the location of the GPS antenna relative to the vessel's reference point.

Caution _____

The positioning system may have internal offset parameters set. Make sure that the antenna offsets are not applied both in the position system and in SIS.

How to setup the output to external sensors

- 1 Tick off if you want to output to either of the following systems
 - Auto pilot
 - Dynamic positioning
 - Depth below keel
- 2 Set the port number, baud rate, data bits, stop bits and parity for each output enabled.

How to enter the waterline for a single beam system

This procedure only applies to single beam echo sounder interfaced to the SIS HWS using NMEA datagrams. The waterline offset is used to compensate for the depth difference between the vessel reference plane and the EA transducer depth.

Note _____

*Waterline for the multibeam echo sounders are input through the **Installation parameters**.*

- 1 Locate the **Waterline (m) Downward (Z)** entry in lower left corner of the **External sensor** dialog box
- 2 Enter the vessel's waterline vertical location (in normal trim) in the vessel's reference coordinate system.

Related operational procedures

- *How to modify the runtime parameters* on page 134

Parameter references

- *External sensors* on page 371
- *Sound speed for EM 2040* on page 305

Enter a sound velocity profile

A sound speed profile must always be taken within the survey area and loaded in **.asvp** or **.actd** format into SIS before the survey is started.

We recommend that you collect at least two profiles at each location. If the two profiles deviates significantly, you should carry out further attempts until you are confident that you have a representative sound velocity profile.

The method used for collecting a sound velocity profile depends on the type of sound velocity probe you are using. You must refer to your sound velocity probe's user documentation for instructions on how to collect the sound velocity data.

There are three stages in the process of entering a sound velocity profile into SIS:

- 1 Collecting the sound velocity profile data
See *How to collect the sound velocity profile* on page 141
- 2 Converting the sound velocity profile data to the SIS .asvp format
See *How to convert your sound velocity profile to SIS format* on page 143
- 3 Checking and preparing the sound velocity profile for SIS
See *How to modify and load a sound speed profile into SIS* on page 151

There is an automated method in SIS for collecting and applying a sound speed profile. This method requires input of sound velocity profiles in one of the SSP format types.

See *How to automatically collect and apply a sound velocity profile in SIS* on page 152.

SIS reads the sound velocity profile in the .asvp and .actd formats only. The .asvp format is an ascii format consisting of a header row and data rows for each depth and sound speed as shown in the following example:

```
( SoundVelocity 1.00 12 200605290813 22.3452678
 66.4483298 4500 200605290813 200605301210 SVP-16 PE 8 )
0.1 1483.6
5.0 1484.2
7.0 1485.3
12.0 1488.1
20.0 1485.7
25.0 1484.0
40.0 1483.8
12000.0 1509.6
```

The .actd format is a special format containing water density in addition to the sound speed. It is used in ROV operations where the scaling factor is automatically calculated. The .actd format is not described further in this section. See *ACTD format* on page 548 for description.

The SIS software package offers a number of utility programs that may assist you in collecting, converting, checking and loading your sound velocity profile.

Program	Description
SmartTalk	Logging sound velocity profile data from an AML sound velocity probe. Logged data in .csv format. Available on the SIS installation DVD
csv2asvp	Converts the .csv file collected using SmartTalk into .asvp format. Available using the SVP Editor utility in SIS
SVPLoader	Logs sound velocity data from an AML or Morse sound velocity probe. Converts the data into the .asvp format. Available using the SVP Editor utility in SIS
SVP Manager	Reads any column based sound velocity file and will when configured convert the file to an .asvp file. Available on the SIS installation DVD

Program	Description
SVP Editor	Reads the .asvp file, displays the profile and holds a number of functions for editing and preparing the profile for use in SIS. A SIS utility program.
SVP Editor	Also reads any column based sound velocity file and converts it to the .asvp format.

Operational procedures

- *How to collect the sound velocity profile* on page 141
- *How to use SmartTalk* on page 142
- *How to use csv2asvp* on page 143
- *How to use SVP Logger* on page 144
- *How to use SVP Manager* on page 145
- *How to use SVP Editor to convert an SVP file to .asvp format* on page 147
- *How to use macros in the SVP Editor to convert an SVP file to .asvp format* on page 149
- *How to modify and load a sound speed profile into SIS* on page 151
- *How to automatically collect and apply a sound velocity profile in SIS* on page 152

Related operational procedures

- *How to modify the runtime parameters* on page 134
- *How to display sound velocity at transducer depth in the Geographical view* on page 163

Related topics

- *Sound speed profile formats* on page 544
- *ACTD format* on page 548
- *SVP Editor* on page 395
- *Raypaths chart* on page 401
- *SVP Logger* on page 406
- *SeaCast* on page 405
- *External sensors* on page 371

How to collect the sound velocity profile

The method used for collecting a sound velocity profile depends on the type of sound velocity probe you are using. You must refer to your sound velocity probe's user documentation for instructions on how to collect the sound velocity data.

In general the method is as follows:

- 1 Prepare the probe for data logging.

There are two methods. Either to collect data through a data cable between the probe and the PC while the probe is lowered, or to collect the data within the probe and download the data to your computer when the probe is recovered.

- 2 Lower the probe slowly from the surface to the bottom, or to a required depth.
- 3 If you are logging data directly to the computer, ensure that data is being recorded.
- 4 Recover the probe slowly.
- 5 Save your profile in the SIS computer.

Note

*If you are using an AML sound velocity probe you may use the **SmartTalk** utility program included on the SIS installation DVD to log the sound velocity profile in a comma separated (.csv) format. The .csv format must then be converted to .asvp format.*

***SmartTalk** is not a Kongsberg Maritime software.*

*Alternatively, for the AML and Morse SVP probes the SIS utility **SVPLogger** can be used to log and directly convert the sound velocity data to .asvp format.*

How to use SmartTalk

The AML sound velocity probe collects data internally during the sound velocity dip. The logging must be configured before the you lower the probe, and the data is downloaded to your computer after recovery of the unit.

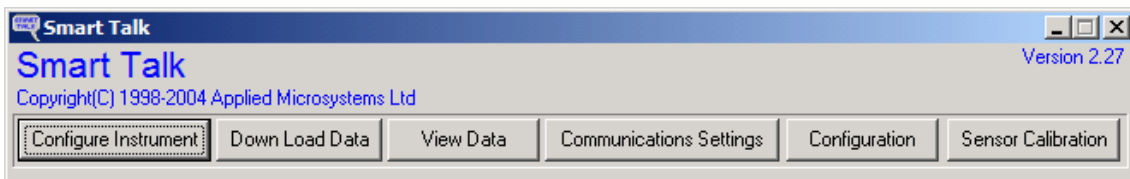

- 1 Connect the probe to the serial port on your SIS computer.
- 2 Press **Configure Instrument** to set up the communication and data logging
- 3 Select your instrument
- 4 Press **Configure**
- 5 Enter a log file name and set the logging parameters according to your requirements
- 6 Press **Program Instrument** to load the settings into the probe
- 7 Disconnect the probe and collect the sound velocity data
- 8 Reconnect when the probe is recovered
- 9 Select **Down Load Data** from the main dialog
- 10 Select your instrument
- 11 Select the correct file and the destination path
- 12 Press **Transfer file(s)** to start downloading
- 13 Select **View Data** from the main dialog
- 14 Select **Load File**
- 15 Evaluate the data briefly
- 16 Press **Export**
- 17 Select **Formatted Comma Separated Values**
- 18 Enter a **Destination file name** with extension .csv

19 Press **Export File**

20 Use the SIS utility **csv2asvp** to convert the file into **.asvp** format.

See *How to use csv2asvp* on page 143

How to convert your sound velocity profile to SIS format

SIS reads the sound velocity format in the standard .asvp (Ascii Sound Velocity Profile) format. Your sound velocity data must be converted to the SIS .asvp format before they can be applied.

Depending on what type of probe you have SIS offers various utility programs to convert probe data into .asvp format.

How to use csv2asvp

csv2asvp converts observation files from an AML SVP sensors in **.csv** format to **.asvp** format

1 Open the **SVP Editor** from the SIS menu **Tools**→**Custom...**→**SVP Editor**.

2 Select **Tools**→**csv2asvp**

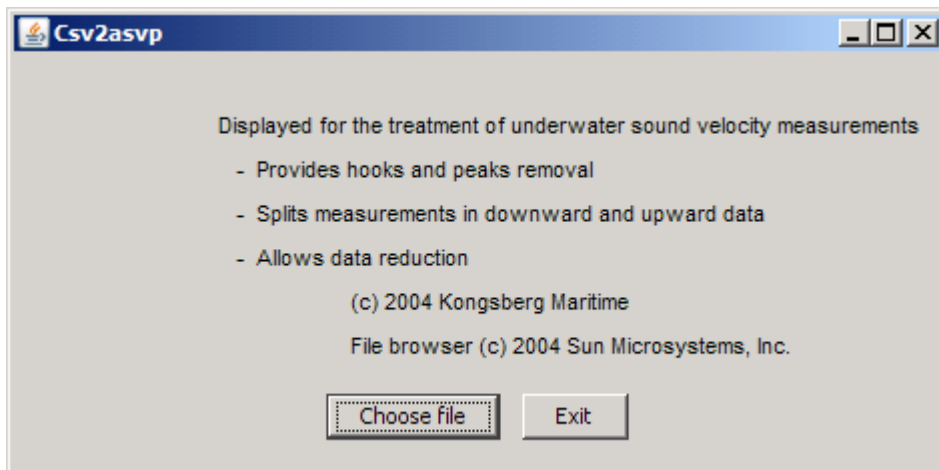

3 Press **Choose file**.

A standard Windows file open dialog appears.

4 Browse for the **.csv** file you want to convert.

A message dialog appears telling you what file you have selected to convert.

5 Click the **OK** button.

A message dialog appears telling you the converting process is done.

6 Click **OK**.

7 Click **Exit** to leave **csv2asvp**

8 Verify that the file is converted.

The new file will have the same name as the original **.csv** file, but now with the extension **.asvp**.

9 Modify and load the sound velocity profile into SIS.

See *How to modify and load a sound speed profile into SIS* on page 151

How to use SVP Logger

SVP Logger logs raw data from **Morse** and **AML** SVP sensors and converts the data to .asvp format

SVP Logger assumes that a **Morse** or **AML** SVP probe is interfaced to the SIS HWS (Hydrographic Work Station) using the **External Sensor Input setup**.

For details, see

- *External sensors* on page 371
- *How to setup the input from external sensors* on page 137

- 1 Select **Tools**→**External sensors**
- 2 Locate the **SVP Logger** field
- 3 Check the **SVP Logger avail** checkbox
- 4 Select input port in the **Port** drop down list
- 5 Press **OK** to exit **External sensors**
- 6 Open the **SVP Editor** from the SIS menu **Tools**→**Custom...**→**SVP Editor**.
- 7 In the SVP Editor, select **Tools**→**SVPLogger**

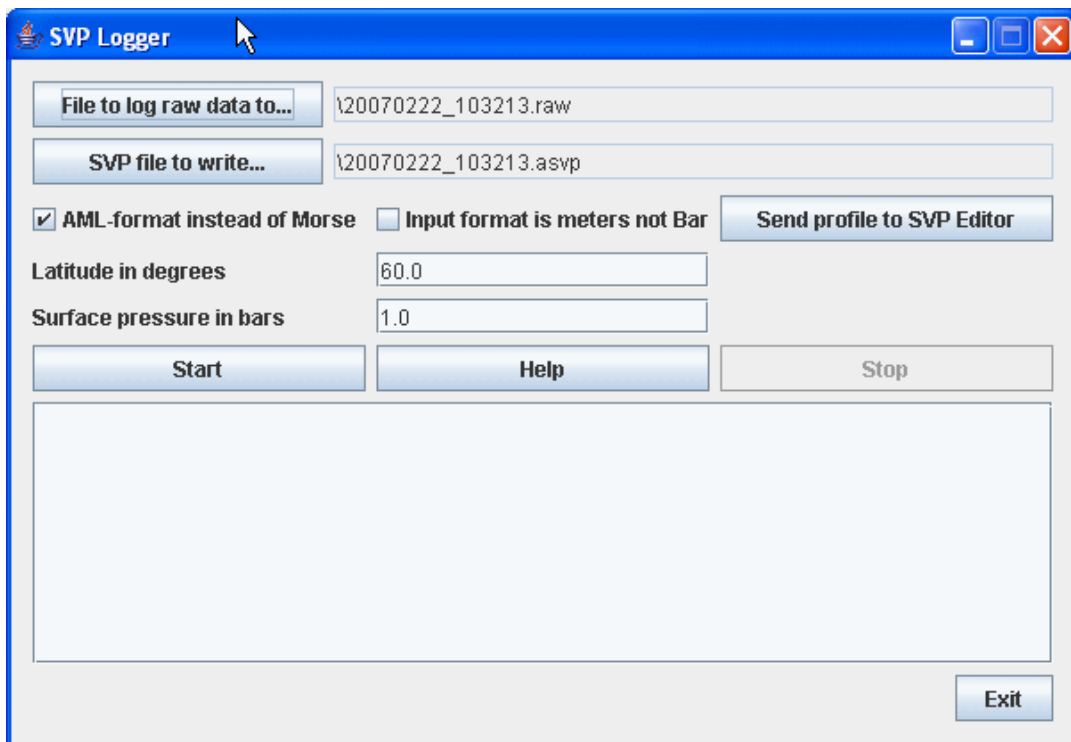

- 8 Select the path of your SVP data by pressing **File to log raw data to...**
- 9 Select the path where you want the converted files to be saved to by pressing **SVP file to write...**
- 10 Select whether your SVP format is AML or Morse by checking/unchecking **AML-format instead of Morse**
- 11 Select whether your observations are in Bars or Meters by checking/unchecking **Input format is meters not Bar**

- 12 Enter your approximate latitude
- 13 Enter the surface pressure in bars
- 14 Press **Start** to start logging
- 15 Press **Stop** to stop logging.
Observe that the content of the .asvp file is displayed.
- 16 Press **Send profile to SVP Editor** to enable modifications to the data.
- 17 Modify and load the sound velocity profile into SIS.
See *How to modify and load a sound speed profile into SIS* on page 151

How to use SVP Manager

When configured **SVP Manager** will convert any column based ascii SVP file to the .asvp format

SVP Manager is a utility program that is included on your SIS installation DVD. You can use SVP Manager to define a standard conversion from your input SVP format to the .asvp format.

- 1 Locate **SVPMan** on your SIS installation DVD.
- 2 Run the installation file called **SVP Manager.msi**.
- 3 Copy the **SVP Manager** program file to the desktop for accessibility
- 4 Start **SVP Manager**.

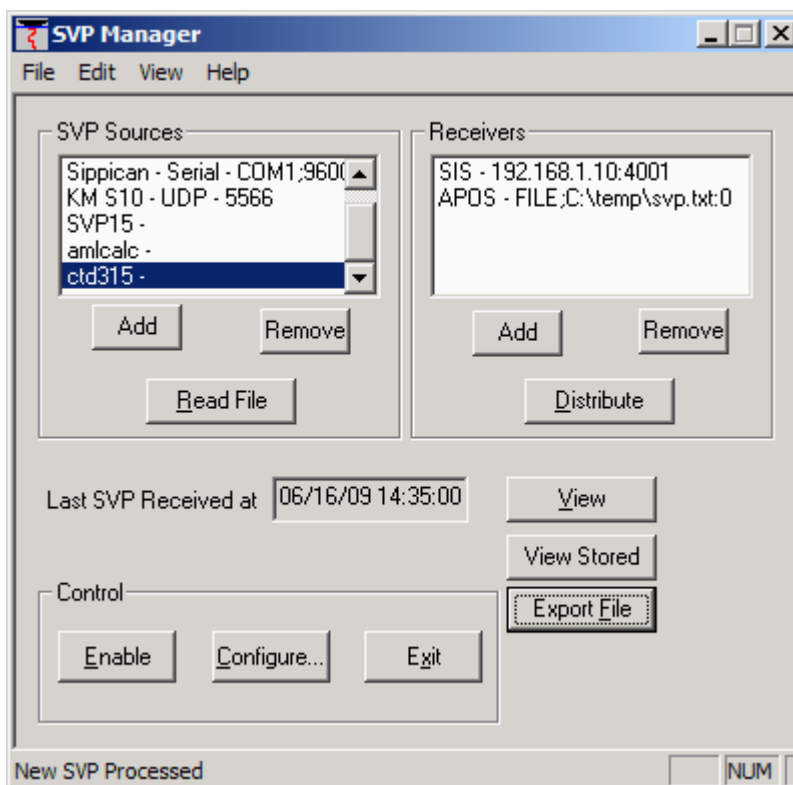

Define the SVP format

First time you are using SVP Manager to convert your SVP data you need to define your format. Some known formats are predefined.

- a Locate the **SVP Sources** area
- b Press **Add**
- c Give a descriptive **Name**
- d Set **Source** to be a **File**
- e Set **Data Type** to **User defined**
- f Press the **Cfg** button to configure the input

The screenshot shows a dialog box titled "User defined format". It has a close button (X) in the top right corner. The dialog contains the following elements:

- "Number of header lines:" followed by a text input field containing the number "4".
- "Delimiter:" followed by a group box containing:
 - Radio buttons for "Tab", "Semicolon" (which is selected), and "Comma".
 - Radio buttons for "Space" and "Other" followed by an empty text input field.
- "Depth field #:" followed by a text input field containing the number "7".
- "Sound Speed field #:" followed by a text input field containing the number "6".
- At the bottom, there are two buttons: "OK" and "Cancel".

- g Enter **Number of header lines** in your input file
- h Select the **Delimiter** used in your input file.

Note _____
Tab and space may appear identical in a text file viewer.

- i Select the column number in your input file where the **Depth** data is located

Note _____
Depth and pressure data can both be selected for this field.

- j Select the column number in your input file where the **Sound velocity** is located

- k Press **OK** to save the configuration
- l Press **OK** to save your user defined SVP source

For each file you want to convert:

- 5 Highlight the SVP source you have created a converting routine for.
- 6 Select **Read file**.
A standard Windows File dialog opens.
- 7 Select the file you want to convert

- 8 Enter an approximate location for the sound velocity profile in the **Enter position** dialog that appears.
- 9 Press **OK**
- 10 Observe that the sound velocity profile is shown in the **SVP Edit** windows that appears.
- 11 Verify that the file has been correctly converted.
- 12 Press **OK**
- 13 Select **Export file** from the SVP Manager main dialog.
A standard Windows Save as dialog opens.
- 14 Save the file the .asvp file to the SIS directory `../common/svp_abscoeff`
- 15 Press **Exit** when you want to leave SVP Manager
- 16 Modify and load the sound velocity profile into SIS.
See *How to modify and load a sound speed profile into SIS* on page 151

How to use SVP Editor to convert an SVP file to .asvp format

This procedure describes how to convert a SVP file from any column based ascii format to the .asvp format read by SIS.

Note

*If your original file format requires a lot of operations to convert to the .asvp format, you may define a macro that runs all operations in one automated process. In that way you only have to define the operations once. See *How to use macros in the SVP Editor to convert an SVP file to .asvp format* on page 149.*

- 1 Open the **SVP Editor** from the SIS menu **Tools**→**Custom...**→**SVP Editor**.
- 2 Expand the view by dragging the boundaries of the window.
- 3 Open the SVP file from the **File**→**Open in editor...** menu
- 4 Change the **Files of Type:** drop down selection to **All files**
- 5 Browse for your SVP input file and press the **Open** button
The **Raw file editor** opens.

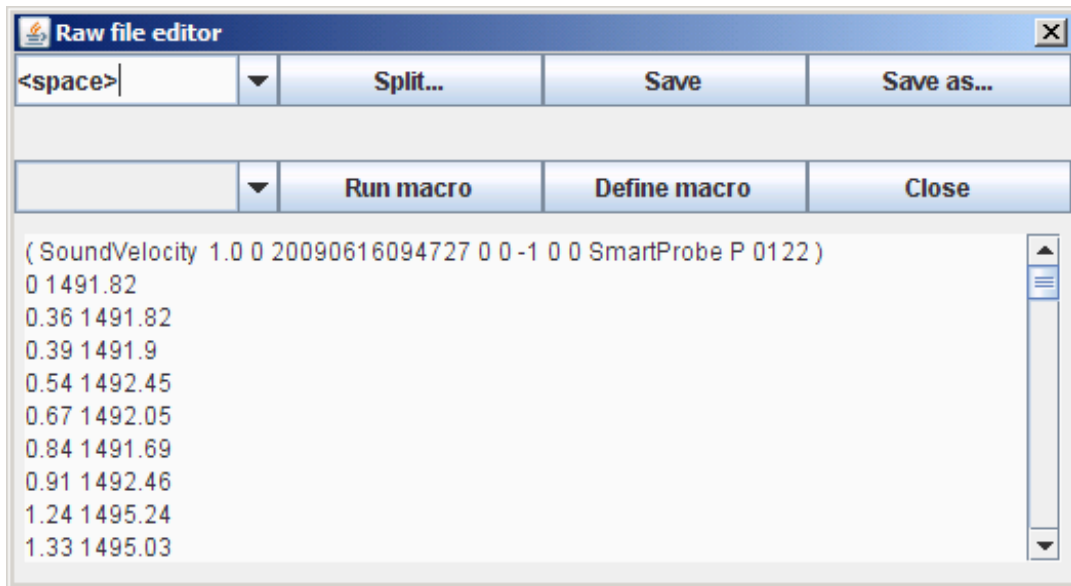

- 6 Remove all header rows by marking them and press the Delete key on your keyboard.
- 7 Select the delimiter from the drop down list.
- 8 Press **Split** to apply the delimiter.
A new window will appear.

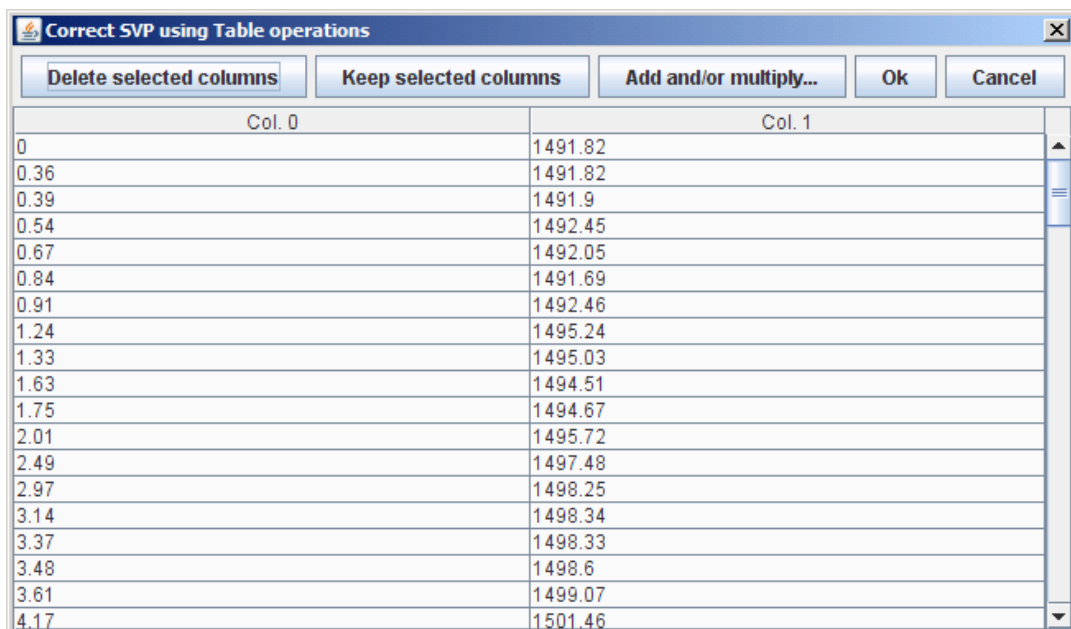

- 9 Mark the columns you do not need.
Position the mouse in the first data row to mark that column.
- 10 Press **Delete selected columns** to remove the columns you have marked
- 11 Press **Add and/or multiply...** to perform offset and scale operations to a column

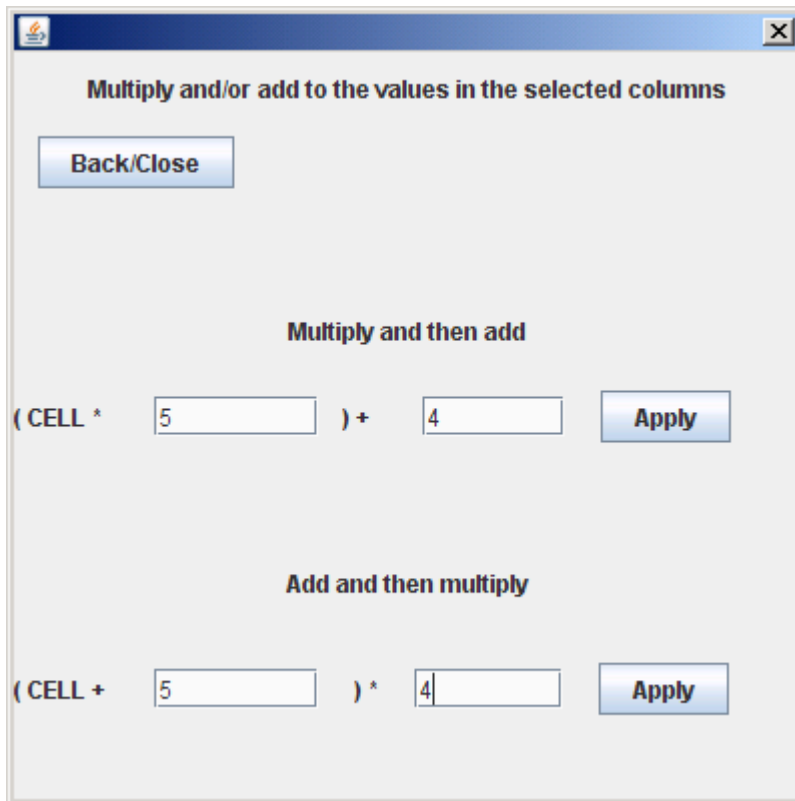

You can perform multiply-add/scale-offset operations in two ways:

- Multiply (scale), then add (offset) $(ab+c)$
- Add (offset), then multiply (scale) $(a+b)c$

Press **Back/Close** when finished. The figures in the selected column will be updated.

- 12 Move the columns by position the mouse pointer on the column header row and drag the column to right position.
- 13 Press **OK** when selected columns are in right place.

You will now return to the **Raw file editor**

- 14 Select **Save as...**
- 15 Save the new file in the SIS directory `./common/svp_abscoeff`

The file extension is automatically set to `.asvp`

- 16 Modify and load the sound velocity profile into SIS.

See *How to modify and load a sound speed profile into SIS* on page 151

How to use macros in the SVP Editor to convert an SVP file to .asvp format

This procedure describes how to define and use a macro to convert a SVP file from any column based ascii format to the `.asvp` format read by SIS.

If your original file format requires a lot of operations to convert to the `.asvp` format, you may define a macro that runs all operations in one automated process. In this way you only have to define the operations once.

- 1 Open the **SVP Editor** from the SIS menu **Tools**→**Custom...**→**SVP Editor**.

- 2 Expand the view by dragging the boundaries of the window.
- 3 Open the SVP file from the **File**→**Open in editor...** menu
- 4 Change the **Files of Type:** drop down selection to **All files**
- 5 Browse for your SVP input file and press the **Open** button

The **Raw file editor** opens.

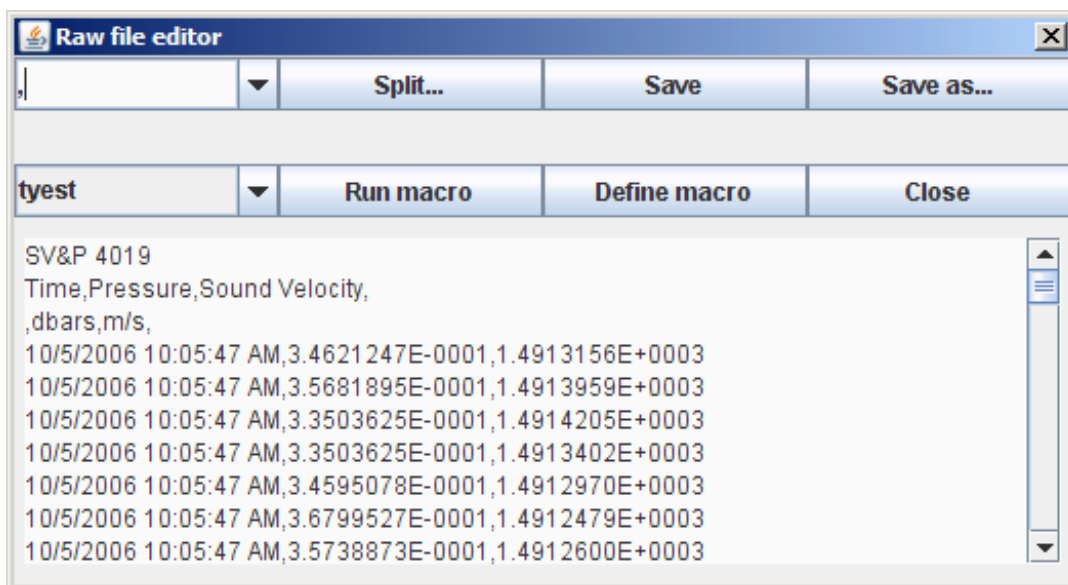

- 6 Remove all header rows by marking them and press the Delete key on your keyboard.
- 7 Press **Define macro** to define a new macro.
A new window will appear.

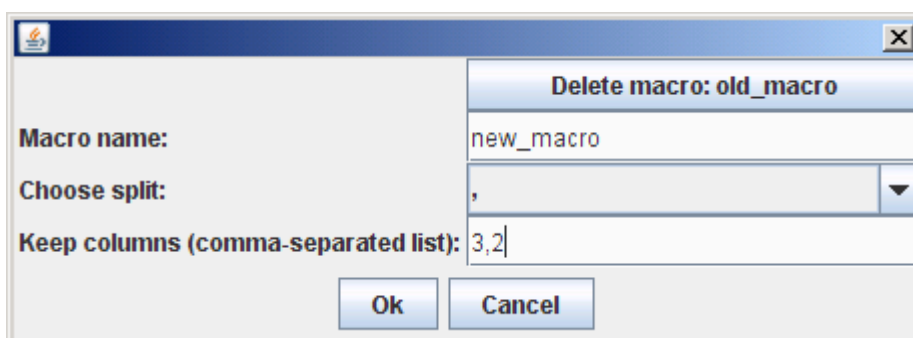

- 8 If required, use the **Delete macro:<macroname>** button to delete currently selected macro.
- 9 Enter a new, unique **Macro name**.
- 10 Select the column split that separates the columns of your format.
- 11 Enter the column numbers that you want to keep, i.e. the depth and the sound velocity readings

You may switch the order of the columns.

Note

Left column is Column 0

- 12 Press **OK** to save the macro.
You will return in the **Raw file editor** window.
- 13 Select the macro you want to run from the drop down box.
- 14 Press the **Run macro** button to execute the selected macro.
- 15 If required, use the **Add and/or multiply...** to perform multiply-add instructions to a column
- 16 Press **OK** when selected columns are in right place.
You will now return to the **Raw file editor**, and a new header has been added.
- 17 Select **Save as...**
- 18 Save the new file in the SIS directory **../common/svp_abscoeff**
The file extension is automatically set to **.asvp**
- 19 Modify and load the sound velocity profile into SIS.
See *How to modify and load a sound speed profile into SIS* on page 151

How to modify and load a sound speed profile into SIS

This procedure assumes that a sound velocity profile file is available in **.asvp** format.

- 1 Open the **SVP Editor** from the SIS menu **Tools→Custom...→SVP Editor**.
- 2 Expand the view by dragging the boundaries of the window.
- 3 Open the **.asvp** file from the **File→Open...** menu
- 4 Adjust the graphical view by
 - 1 Select **From depth** and **To depth** according to your depth range
Use the scroll bar on the right to scroll through your data.
 - 2 Select **From speed** and **To speed** according to your recorded sound speed values
or
 - 3 Enable **Automatic speed scale** to automatically adjust the scale to display all sound speed observations
- 5 Check the observations for double entries or upward depths by choosing **Tools→Check profile**
Observations that are suggested removed are highlighted.
- 6 Press **Delete row** to delete highlighted entries.
- 7 Remove gross errors/spikes from the profile by selecting the point you want to remove
- 8 Press **Delete row** to delete highlighted point
- 9 Continue step 7 and 8 until the profile is acceptable
- 10 Extend the profile from the **Tools→Extend** menu.

This will add sound velocity values from last observed depth down to 12000 meters depth.

- 11 Thin the profile from the **Tools**→**Thin Profile** menu.
This will reduce number of observations to adopt to the PU's limitations for sound velocity observations
- 12 Save the file from the **File**→**Save as...** menu
It is recommended to use a filename that identify date, time, place and that the file is thinned
- 13 Select **File**→**Send primary svp to echosounder** to send the profile selected as you primary profile to SIS.
- 14 Return to SIS.
- 15 Select **Sound speed** in the **Runtime parameters** frame
- 16 Use the browse button to open the correct **.asvp** file.
Normally the file will have been selected via the **Send primary svp to echosounder** command from SVP Editor.
When selected the file name will be shown in the text field next to **Use Sound Speed Profile**. The text field background colour will turn yellow, notifying that the input must be accepted to be applied.
- 17 Press **Use Sound Speed Profile** to apply the selected sound speed profile

How to automatically collect and apply a sound velocity profile in SIS

This procedure applies when you have a sound velocity input into SIS via the Ethernet. This applies e.g. to realtime collection of the sound velocity profile from moving profilers.

- 1 A profile is obtained with a data set in accordance with one of the SSP format types for immediate use, i.e S00, S01, S02, S03, S04, S05, S06 or the new S07.
- 2 The obtained profile must be extended and made error free.
This step is vital for the process to carry on.
- 3 The extended and error free profile is sent to SIS via the Ethernet network using UDP and port 4001 on the SIS HWS.
- 4 The profile is received by SIS and checked for errors. If an error is detected at this stage the automatic process is stopped and you will be notified for manual intervention.
- 5 The error free profile is used to generate a standard depth/sound speed profile which is distributed to all started echo sounders (PUs). In addition, a number of absorption coefficient profiles are made, one for each major sounder frequency used. The echo sounders are updated with the new absorption coefficient values by SIS when appropriate. The absorption coefficient profiles are generated based on the CTD information in the received profile (i.e. S01, S02, S03, S04, S05, S06 or S07) or from the operator set salinity when no CTD information is available (i.e. S00).
- 6 The SIS operator display is updated with the new profile name (based on date and time from the received profile) in the **Runtime parameter** frame. The profile will also be displayed graphically in the **Sound velocity profile** frame if opened.

Related topics

- *Handling of SSP datagrams* on page 539

Start the echo sounder

The echo sounder is started by selecting the desired echo sounder from the **Echo sounder - not started** combo box. The **Logging**, **Pinging** and **Line counter** buttons will all be disabled until the echo sounder is ready. When the echo sounder is ready, you can start to ping.

How to start the echo sounder

Before you start pinging, the echo sounder must be turned on.

- 1 Press the **Rescan** button to scan for available echo sounders on the network.
- 2 Select your echo sounder from the **Echo sounder - not started** combo box.

Single beam echo sounders must be set up and started manually on its own Operator Station.

Autostart

If the echo sounder is powered before SIS is started, you may set the echo sounder to start automatically when it is detected by SIS on the network.

Autostart is enabled from **Tools**→**Custom...**→**Set parameters** under the **Startup options for the system** settings.

For those who have more than one echo sounder on the same network, echo sounders may start automatically when detected on the network, but only when the detected echo sounders are the same as last time SIS was started. This means that Autostart is not activated when new echo sounders are detected and/or previous used echo sounders are missing. The Autostart mechanism may be enabled/disabled by a setting in the SIS database. Default setting is disabled.

Automatic Built-In Self Test at echo sounder start-up

When an echo sounder is started it is an option to run all defined BISTs (Built In Self Test) for the echo sounder automatically. This option is controlled (*On-Off*) from the **Tools**→**Custom...**→**Set parameters** under the **Startup options for the system** settings. Default setting is *Off*, i.e. BISTs are not run automatically. When changed it is not necessary to restart SIS.

When this option is *On* and an echo sounder is started an **Installation and Test** tear off window will be displayed showing the BIST tabulator content. If an Installation and Test window is already opened this window will be used.

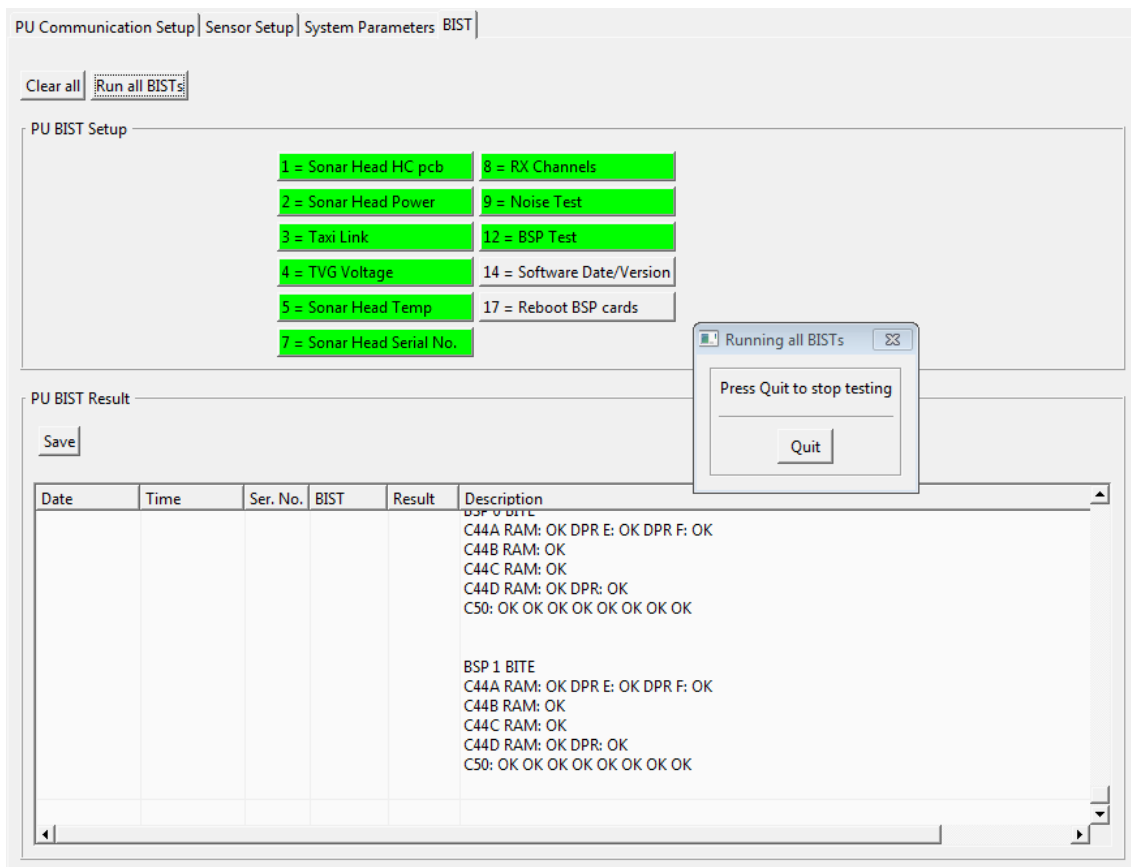

A **Run all BISTs** test sequence is then automatically started for each available echo sounder head. This sequence can be cancelled at any stage by pressing the **Quit** button in the pop-up window that is displayed. When cancelling, the current test must run to completion before the sequence halts.

The progress of the tests can be monitored by looking at the status colour in the test buttons or in the **PU BIST Result** area. The results of the completed tests can be read at any time during the test run.

When the test sequence has run to completion the test results may be saved by pressing the **Save** button.

Note

The full selection of BISTs for an echo sounder may contain some special items that should not be run during start-up. These include e.g. re-booting of BSP cards, upload of new head software etc. Such tests will not be run in this context.

Some tests may require a considerable time to complete. There is no countdown or any other indication of remaining time in the current implementation.

How to interface a singlebeam echo sounder in SIS

EA singlebeam echo sounders, from version 2.4.0.0 and onwards, have the ability to be used in a SIS compatible mode of operation. This will enable the EA echo sounder to be integrated in the SIS topside environment for control, display and data logging purposes.

From the SIS point of view an EA in SIS operational mode will behave as a traditional EM echo sounder except for some operational restrictions and a different data logging format.

An EA in SIS operational mode will broadcast its presence on the network using port 1999. When detected by SIS it will be named EA600 and it can be started by SIS in the same manner as used for the EM range of echo sounders.

Only a small number of the different SIS information display frames will be active for the EA echo sounder. Most noteworthy, no installation and runtime parameter settings are currently available for this echo sounder. The numerical display will have a restricted function mainly showing position information, speed and depth. The major display for the EA operation in SIS will be the Geographical view frame. It is used to present the depth information in gridded format based on the logged data. The ship's position will be shown as a cross, as no heading is currently available in the EA position datagram.

The pinging and logging operation is controlled by the standard SIS buttons used for this purpose. The data being sent from the EA echo sounder, and logged by SIS, is processed data (i.e. not raw data). The following is a list of the different EA datagram types being logged:

- GL (Geographical Location)
- CS (Comment String)
- D1, D2, D3, D4 (Detected bottom depth)
- Q1, Q2, Q3 (Echogram – post processor)
- PR (Parameter request)
- PE (Parameter Enter)
- ST (Status Telegram)
- MS (Motion Sensor)
- SV (Sound Velocity)

The data is stored in files with a '.dg' extension. The file name format is the same as for standard SIS '.all' files. The '.dg' files will always contain a 'CS (Comment String) datagram as first entry. It contains the date information (which is not found elsewhere).

Raw data logging can be performed by the EA itself to a local hard disk in parallel with the logging operation in SIS. I.e. new EA raw data files are created in parallel with the lines logged in SIS. This feature is turned on by default, but may be turned off by selecting **Tools**→**Custom...**→**Set parameters**→**Logging** and setting **EA raw data logging (No=0, Yes=1)** to 0.

Note

EA is a single beam echo sounder normally only measuring the depth straight below the ship. This implies that SIS is logging relatively small amounts of data and if running a survey in straight lines the gridded result might be meagre. This is caused by the method used for gridding based on making triangular planes between three measured depths. A better gridding result will be obtained when the survey contains several lines, more or less in parallel and close.

Note

The EA data must contain navigation data to be read by SIS.

- 1** In the EA software:
 - a** Open the **Interfaces**→**Network Interface** dialog and locate the **Datagram output** field.
 - b** Check the **Navigation** check box to send navigation data to SIS.
 - c** Press **OK**.
 - d** Open the **Install**→**Navigation** dialog and locate the **Protocol** field.
 - e** Select the **NMEA** protocol.
 - f** Press **OK**.
 - g** Open the **File**→**Operationg** dialog box
 - h** Check **SIS** checkbox.
 - i** Press **OK**.
The SIS display will apparently freeze.
- 2** Go to **SIS**
- 3** Press **Rescan** to scan for recognized systems on the network.

Note

Both EA 400 and EA 600 systems will be identified by SIS as EA 600.

- 4** Start the EA 600 system from the **Not started** drop-down menu of SIS.
Allow SIS to initialize the use of the EA system. SIS is ready for use when the **Logging** and **Pinging** buttons becomes selectable.
- 5** Select **Pinging** from SIS to start EA pinging.
or
- 6** Select **Logging** from SIS to start EA pinging and raw data logging.
The EA system will continue in normal operation.

Your vessel will be shown in the geographical display of SIS.

All EA parameter settings and the display of the Echograms will be shown in the EA software.

Detecting the echo sounder on the network

This procedure describes how to detect echo sounders on the network, and applies only to situations where you are using SIS with more than one echo sounder at the same time.

When the SIS program starts it will automatically scan the network for connected echo sounders. This will normally take approximately 10 seconds. The detected echo sounders will be compared with a list of echo sounders detected on the previous run of the program. If new echo sounders are detected they will automatically be configured in the SIS program according to a predefined setup for each echo sounder type. This will take approximately 5-10 seconds for each new echo sounder. All detected echo sounders will then be listed in the **Current echo sounder** combo box, available for selection of an echo sounder in further configuration.

In addition, the same echo sounders may be listed in the **Echo sounder - not started** combo box, depending on whether the autostart mechanism is triggered or not. The autostart mechanism will automatically start all detected echo sounders, provided they are exactly the same as on the previous run, that is, if no echo sounders are missing and no new echo sounders are added since the last run. Otherwise the echo sounder will appear in the **Echo sounder - not started** combo box and must be started manually.

Choose which system you want to change the parameters for, by selecting it from the **Current echo sounder** combo box.

Since several types of echo sounders, with different purpose and capabilities, are handled by the SIS software, the parameter settings for the different types will vary depending on system.

The multibeam echo sounders broadcasts their existence on the network. EA single beam echo sounders, from version 2.4.0.0 and onwards, will also be detected on the network by SIS. Earlier versions of single beam echo sounders and other sensors transmitting NMEA datagrams must be set up manually in SIS. Use the **Add instruments combinations** found in the **Tools** menu. When defined, these sensors will be handled the same way as echo sounders that broadcast their existence on the network.

The external sensors, connected directly to the HWS, such as a sound velocity probe, heading and position sensors are registered in the **External sensors** found in the **Tools** menu.

Note

It is important that the default parameter settings for each echo sounder is checked and/or modified according to the operational and physical conditions applicable for the current echo sounder.

Parameter references

- *Logging* on page 341
- *Instrument combinations* on page 377

Related topics

- *Main toolbar* on page 33

- *Echo sounder – Not started list* on page 35
- *Current echo sounder* on page 36

Import a Neptune grid to SIS

If you have a terrain model generated by the Neptune software and want to load this as your background grid in SIS you will need to add a definition of the projection to the Neptune file(s).

How to import a Neptune grid to SIS

- 1 Select **Tools**→**Custom...**→**Create grids from ascii files**
- 2 Select the **projection** of your current SIS survey, i.e. the projection you want the imported Neptune grid to appear in. The datum is given by the header of the Neptune file.
- 3 Set **Grid size in meters** and **Number of cells in processing grid** according to depth and coverage of your data.
- 4 Press **Select grid output directory...** to specify where to store the grid. Note that this directory must exist and be accessible for writing.
- 5 Type a descriptive **Grid name**.
- 6 **Select ascii input files** opens a file selection dialog where you can browse for the Neptune files to import.
- 7 Select **Remove files in list** if you want to remove a selected file from the list.
- 8 Press **OK** to start the process.
- 9 Select **File**→**Import/Export...** from the SIS main menu.
- 10 Press the **Import** button.
- 11 Browse for the directory where you selected to store the grid and select the directory having the grid name that you entered.
- 12 Press **OK** to return to the **Import/Export** dialog box.
- 13 Highlight the survey to import and press **OK**.
- 14 In the **Geographical** view, press **Zoom to world** to display the grid.

Note _____

The GridEngine must be running for this program to work.

Note _____

If the process causes GridEngine to stop you may have to kill the Import from the process manager and restart the GridEngine.

Parameter references

- *Projection and datum parameters* on page 384

- *Import/Export* on page 352
- *Create grid from ASCII files* on page 451

Start pinging

How to start pinging

Pinging must be started manually after the echo sounder is ready. When pinging is *On*, the **Waterfall**, **Cross track** and **Beam intensity** windows becomes active.

- 1 Select the echo sounder you want to ping with in the **Current echo sounder** combo box.
- 2 Press the **Pinging** button on the toolbar. The button is red when *Off* and green when *On*.

The selected echo sounder will now start transmitting.

Related topics

- *Main toolbar* on page 33
- *Current echo sounder* on page 36
- *Beam intensity view* on page 61
- *Cross track view* on page 64
- *Waterfall view* on page 73

Check sensor input

Proper operation of the external sensors are vital for the SIS operation. These are sensors connected to the PU (Processing Unit) and not directly to the HWS (Hydrographic Work Station).

Note

*The **PU – Processing Unit** may be a separate hardware unit or an integrated part of the **TRU – Transceiver Unit** cabinet, depending on echo sounder system.*

For SIS it makes no difference whether the communication is with a PU or a PU inside a TRU. The term PU is used in this manual.

External sensors are continuously monitored in SIS. The **Time series** window presents data from the motion sensor. Sensor data is also shown in the **Numerical display** window. Sensor errors are reported in the **Message service** window.

How to monitor the external sensors in SIS

- 1 Select the **Time series** frame.
- 2 Verify that roll, pitch and heave data is being received by SIS.

- 3 Verify that the roll, pitch and heave data appears according to expected values.
- 4 Select the **Numerical display** frame.
- 5 Verify that values read from all your external sensors, including roll, pitch, heave and sound velocity are close to what you expect.
- 6 Select the **Message service** frame.
- 7 Scroll through the logged messages and verify that there are no messages indicating problems reading the external sensors.
- 8 Select the **PU sensor status** frame.
- 9 Verify that your sensors are marked with green, meaning that sensor is selected as active and that data is being received.
- 10 Select the **Sensor layout** frame.
- 11 Verify that your sensors are located correctly

Related topics

- *Time series view* on page 72
- *Numerical display* on page 68
- *Message service view* on page 69
- *PU sensor status view* on page 86
- *Sensor layout view* on page 98

Check echo sounder main functions

Before you start logging, you are advised to make sure that the echo sounder system is locked on the bottom and that the swath coverage is as expected.

The **Geographical** window presents a real time view of the system(s) performance during online operation. The window shows the raw data from the system(s) after corrections have been applied for vessel attitude and sound speed.

Note

The following information applies to multibeam echo sounders only. Single beam echo sounders and GPS equipment do not have this option.

How to display realtime depths

While pinging or logging, realtime depths may be displayed in the **Geographical** window using the following setup:

- 1 Press the **Option** button in the **Geographical** frame's toolbar.
- 2 Expand **Survey** in the left pan of the Geographical Options menu.
- 3 Select the **Realtime Depth**.
- 4 Press **OK**

How to verify echo sounder main functions

Check the following windows:

- 1 Check the **Waterfall** window for a continuous bottom.
- 2 Check the **Cross track** window to see the depths for all the beams ping by ping.
- 3 Check the **Beam intensity** window for reasonable backscattering strengths for each individual beam.
- 4 Check the sensor status in the **Numerical display** window and in the **PU sensor** status.
- 5 Check the **Water Column** display if available.

Related topics

- *Geographical view* on page 57
- *Beam intensity view* on page 61
- *Cross track view* on page 64
- *Numerical display* on page 68
- *PU sensor status view* on page 86
- *Waterfall view* on page 73
- *Water column view* on page 75

Geographical frame settings

How to display seabed imagery data in the Geographical view

Note

The grid must be generated with the seabed image options enabled. The seabed image can be generated in real time or it can be generated during import of logged raw data.

- 1 Generate seabed image data in real time by
 - a Select the **Survey administration** frame.
 - b Open the **Survey template handling** tab.
 - c Select the **Advanced** tab.
 - d Select the **GridEngine parameters** tab.
 - e Press the **Processing...** button.or generate seabed image data from logged raw data by
 - a Select **File→Import/Export...**
 - b Select **Raw data files**
 - c Enter Survey name, raw data path and other survey parameters as appropriate
 - d Locate the **Grid Engine Parameters** field at the bottom of the dialog
 - e Enter appropriate Number of cells and cell size.

- f Press the **Processing...** button.
- 2 Press the **Advanced...** button.
- 3 Tick off for **Seabed Image Processing in Grid Engine**.
- 4 Type a name for your new **Seabed Image Processing** rule the text field next to the **Save as** button.
- 5 Press **Save as**
- 6 Press **Apply** to make changes active.
- 7 Press **OK** and next **Accept** to return to the **Raw Data Files** dialog box.
- 8 If you are creating the grid through importing raw data, press **OK** now and await the import process to finish.
- 9 Select the **Geographical** frame.
- 10 Select the  **Options** button.
- 11 Select **Survey**→**SIS Based Surveys** in the left tree structure.
- 12 Locate the **show/hide** field to the right of the dialog.
- 13 Check the **Sonar Display Grid** option.
- 14 Press **OK**
- 15 Select the area in the geographical view that you want to display with high resolution seabed image by:
 - a Click left mouse button in start point for the area.
 - b Drag the mouse to the end point for the area.
 - c Press the shift key.
 - d Release the mouse button and the shift key.
- 16 Observe that selected area is shown with seabed image mosaic.

How to display sound velocity at transducer depth in the Geographical view

This functionality requires that your raw data (*.all files) contains data from a sound velocity probe that is connected at the same or close to the depth of your transducer.

- 1 Open a console window, e.g. as follows
 - a Press the Windows **Start** button
 - b Select **Run...** in the right side of the Start menu
 - c Type **cmd** in the text field that appears
 - d Press **OK**
- 2 Go to the directory where the SIS executable files are located, i.e. the **SIS\bin** directory.
To change drive and directory in a console window:
 - a Type the drive letter, e.g. **C:**, and press Enter to change the drive
 - b Type **cd** to change directory to the root directory

- c Type `cd <sub-folder> \<next sub-folder>` to change the directory to an existing directory below, e.g. `cd program files\Kongsberg Maritime\SIS\bin` to change to the SIS\bin directory
- 3 Run `makeSoundSpeedAtHeadFile.bat` with the path to the raw data as argument. E.g. if your raw data is stored at `c:\sisdata\raw\testdata` you must type the following in the command window:
`makeSoundSpeedAtHeadFile.bat c:\sisdata\raw\testdata`
- 4 Observe that the program is running by reading the raw data files you have specified. When completed the following message will be displayed in the command window:
File soundspeed.txt can now be imported into SIS
The new file will be stored at the same location as you run `makeSoundSpeedAtHeadFile` from.
- 5 Return to SIS
- 6 Select **Tools**→**Custom...**→**Create grid from ascii files**
- 7 Select the **Project** that your data was logged in
- 8 Select a **grid size** and **number of cells in processing grid**.

Note _____

The grid cell size should be set a lot larger than you would for a standard survey.

- 9 Select the output directory and a name of your new gridded sound velocity data
- 10 Press **Select ascii input files...** and browse for the `soundspeed.txt` file
- 11 Enable the selection of the file by highlighting the file name in the **File** list
- 12 Press **OK** to start the importing.
A status window will be displayed as the data are converted into grid data
- 13 Select **File**→**Import/Export...**
- 14 Press the **Import** button to select a gridded data set
- 15 Browse for the folder named after the survey name set in the **Create grid from ascii files** process
- 16 Highlight the selected survey and press **OK** to import
- 17 Press the **Zoom to world** button in the Geographical display toolbar
- 18 Verify that the sound speed is displayed.

Note _____

SIS will interpret the sound velocity as a depth value, so the legend will display 'Depth' even though the values are the sound velocity.

Note

*The sound velocity data may be easier to read if you display the data as points, rather than filled polygons. Select the **Display option** button, then go to **Survey**→**Gridded data** and set **Drawstyle** to **Points**.*

How to display a smooth surface

To display a nice and smooth model of the seafloor, use the **Option** button and choose **Survey**→**SIS based survey**→**Depth operations: Min**. This will select the minimum value in each grid cell and create a surface from them. Noise will be hidden in this surface, but it will be the shallowest surface drawn very smooth.

- 1 Press the **Geographical option** button
- 2 Expand **Survey** in the left tree structure
- 3 Select **SIS based survey** in the tree structure
- 4 Locate **Depth operation** in the mid field on the right side of the window
- 5 Set **Depth operation** to **Minimum**

How to look for artifacts

Inspection mode is used to scan for objects on the seafloor and to filter out noise that may look like objects. The **I** button is used to toggle **inspection mode** on and off. When in inspection mode, the LOD is set to 0, depth operation is set to median depth and the depth scale factor is set to 2. Toggling the **I** button a second time will restore the previous settings.

Alternatively, you may manually set the inspection parameters as follows:

- 1 Press the **Geographical option** button
- 2 Expand **Survey** in the left tree structure
- 3 Select **SIS based survey** in the tree structure
- 4 Locate **Depth operation** in the mid field on the right side of the window
- 5 Set **Depth operation** to **Median**
- 6 Select **Gridded data** in the tree structure
- 7 Locate **Level of detail**
- 8 Choose a smaller **Level of detail (LOD)**
You should not start using level of detail 0, as this may overload the system resources. Instead try to use an increasingly smaller level of detail until a good picture is found.
- 9 Select **General** in the tree structure
- 10 Locate **Light source**
- 11 Try to turn the **light source** on and off.
When off, the light source will follow the mouse cursor and make it easier to see shadows from different angles.
- 12 Select **Survey** in the tree structure

13 Locate **Depth scale factor**

14 Try to change the **Depth scale factor** to see shadows even better.

How to create and use a GeoTIFF background image in the Geographical view

Note

GeoTIFF is a standard which allows georeference information to be embedded within a TIFF file.

You can create and display a GeoTIFF image from gridded survey data. You can also import a GeoTIFF file into SIS and display it as background in the Geographical display.

How to create a GeoTIFF background image from the Geographical view

A gridded survey must be loaded in the Geographical view in SIS.

- 1** Select the area you want to create a graphical GeoTIFF file from.
- 2** To create a picture with best possible resolution, select the **Geographical Options** button, locate the **Level of Detail** field, and select the Level Of Details (LOD) that gives the best presentation of your selected area.

- 3** Press the **Save background data** button .

Three files are created in the background directory, i.e.
\`sisdata\common\background`:

- `gvsor` – the GeoTIFF file
- `gvsor_tmp.tif` – a standard tiff file (not geo-referenced)
- `gvsor_tmp.tfw` – a tiff world file (geo-referencing information for the tiff file)

- 4** Rename and copy the created file if you want to keep it.

How to use the GeoTIFF file in the Geographical view

A GeoTIFF file can be give useful background data information for an area, e.g. data from an earlier survey in the area. To load a GeoTIFF file to be displayed as background data in SIS:

- 1** Select **File**→**Import/Export**
- 2** Locate the **Data Types** field
- 3** Select **Background Images**
- 4** Press the **Import** button

The **Background Image Information** window appears

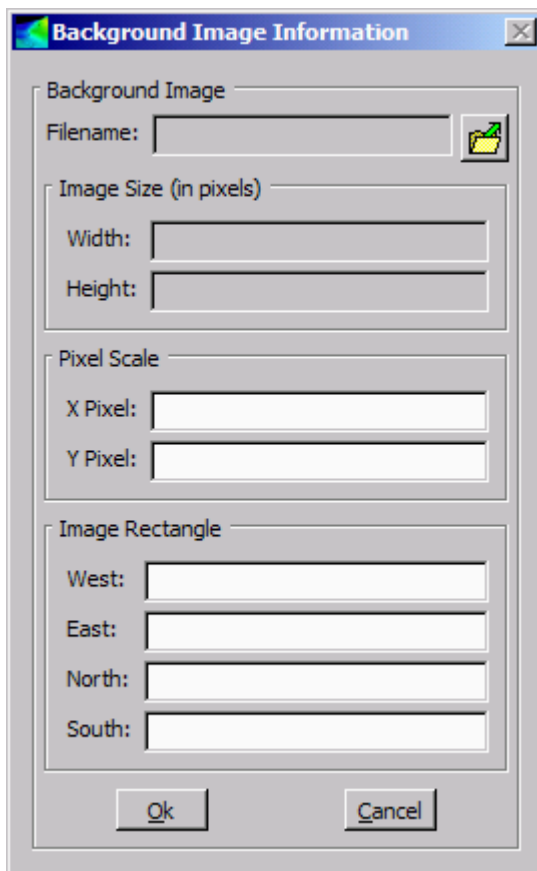

- 5 Browse for the GeoTIFF file by pressing the browse button in the upper right corner. When selected the image and georeference information fields in the **Background Image Information** window will be completed.
- 6 Press **OK** to leave the **Background Image Information** window
- 7 Press **OK** once more to leave the **Import/Export** window

You will now have a background image in the Geographical view. The GeoTIFF files will with it's georeferenced information be displayed in the correct projection and scale.

The following figure shows an example of the use of a GeoTIFF background image. A high resolution image of the survey is displayed on top of a loaded survey, which in this example is displayed 50% transparent.

Figure 8 Example of use of GeoTIFF background image

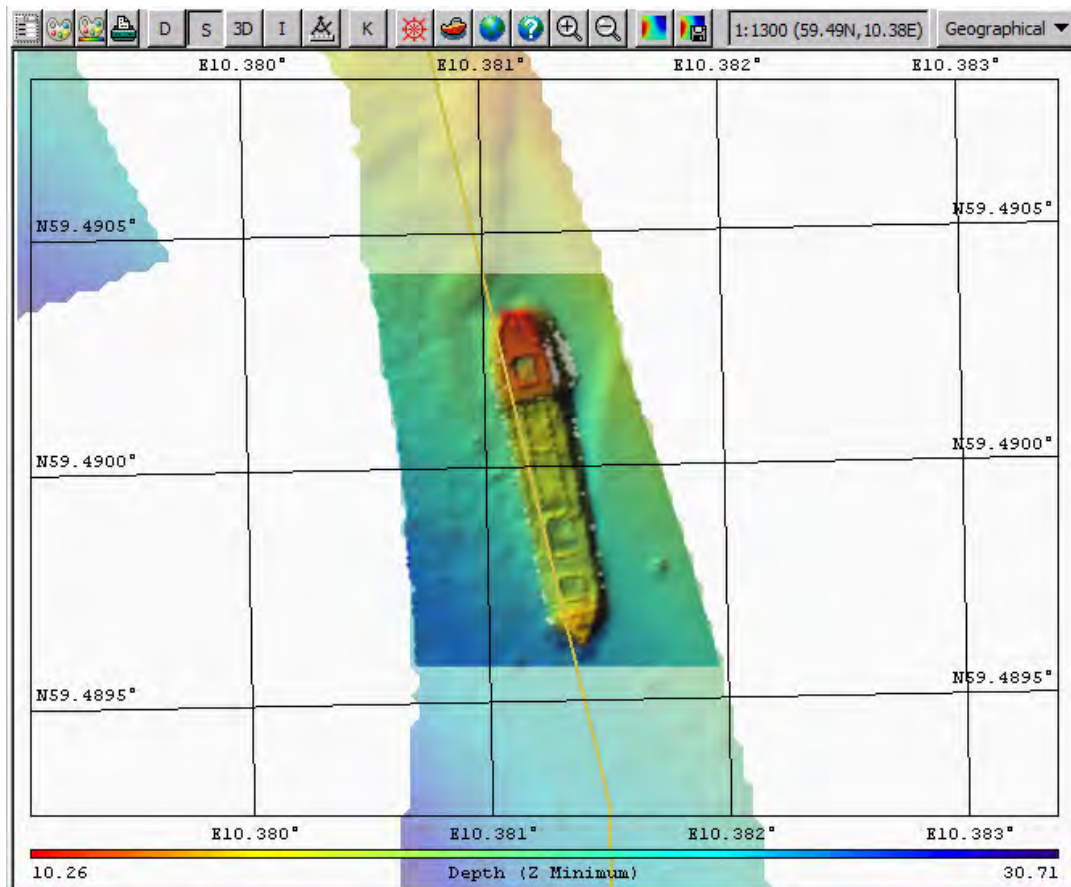

Related operational procedures

- *How to enter survey parameters* on page 114

Parameter references

- *Geographical – Display options* on page 211
- *Geographical – Inspection mode* on page 223
- *Geographical – Save background image* on page 224
- *GridEngine parameters* on page 269
- *Data cleaning* on page 317
- *Import/Export* on page 352
- *Create grid from ASCII files* on page 451

Related topics

- *Geographical view* on page 57
- *Keyboard and mouse in the Geographical view* on page 44

Start and stop logging

Logging must be started manually after the echo sounder is ready. In the **Current echo sounder** combo box, select the echo sounder you want to start.

Note that if pinging is *Off* when logging is turned *On*, pinging will automatically be turned *On*. If logging is *On* and pinging is turned *Off*, logging will automatically be turned *Off*.

How to start and stop logging – Alternative 1

During the survey, the vessel navigates along the pre-planned survey lines. Logging must be started at the beginning of each line. Stop the logging at the end of each line and start it again at the beginning of the next.

At the start of every survey line:

- 1 Press the red **not logging** button on the toolbar.
- 2 Verify that logging starts by that the button turns green.
- 3 Press the green **logging** button when the vessel has reached the end of the line.
- 4 Transit to the next line.
- 5 Press the red **not logging** button when starting the next line.
- 6 Press the green **logging** button when the final survey line has been completed.

How to start and stop logging – Alternative 2

You can also start the logging at beginning of the first line and let it run continuously, changing line number only at start of each new survey line.

At the start of the first survey line:

- 1 Press the red **not logging** button on the toolbar.
- 2 Verify that logging starts and the button turns green.
- 3 Press **Line Cnt (xxxx)** at the beginning of each survey line.
- 4 Verify that a new line number has been assigned.
- 5 Press the green **logging** button when the final survey line has been completed.

Related topics

- *Current echo sounder* on page 36
- *Line counter toolbar set* on page 37

How to save data

When the echo sounder has started logging, data is automatically saved to disk.

The **Line counter** button on the toolbar shows the line count for the currently selected echo sounder.

To avoid very large log files the counter for all active echo sounders are incremented automatically every 30 minutes (this is configurable). This, however, only happens when the counter has not been incremented by other means within the last 30 minutes, i.e. by pressing the line counter button or by stopping and restarting logging. **Interval for line counter** is set from **Tools**→**Set parameters**→**Logging**.

A full disk warning will be given. When a full disk warning is received, you must copy the surveyed data to an external storage device and delete the data from the logging computer.

How to verify data logging

To verify that data is actually being logged, and that nothing has caused the logging process to stop or not to start at all, there are different methods:

- 1 Verify that logging is started without any error messages or pop-up messages appearing.
- 2 If you have not deliberately turned off the display of gridded data, the display of gridded data is an indicator of that data is being logged. It is the logged data that is the basis for the gridded data. The realtime tail or the realtime displays uses data directly from the echo sounder and are thus no indication as to whether data is being logged or no.

Note that missing gridded data also may be caused by memory problems, and gives therefore no firm indication of that logging of raw data has stopped.

- 3 Open the Windows Explorer and locate the raw data directory. Verify that the raw data file, `.all` file with current time, is being updated.

Parameter references

- *Logging* on page 341

How to log water column data

Water column data can be logged to either the standard log file (`.all`) or to a separate water column file (`.wcd`). Water column data can not be logged to both files simultaneously. Water column logging to separate file is enables as follows:

- 1 Open the **Installation parameters** frame.
- 2 Select the **Output setup** tab.
- 3 Enable **Log watercolumn to separate file**.
- 4 Open the **Water Column** frame.
- 5 Select the **Show/Hide** toolbar button
- 6 Toggle logging on/off by checking/unchecking the **Logging** option located as second option in the dialog.

How to log stave data

Stave data can be logged to the currently opened `.all` file.

- 1 Open the **Stave display** frame.

- 2 Select the **Show/Hide** toolbar button.
- 3 Enable **Logging**.

To enable this logging the following conditions must be fulfilled:

- The **Stave display** frame must be open and remain open.
- Standard logging must be started/active (i.e. the **Logging** button in the SIS main toolbar must be green).

Parameter references

- *PU communication – Output setup* on page 279
- *Water column – Logging* on page 247
- *Stave display – Show/hide* on page 249

Perform a system calibration

This section contains the following procedures:

Operational procedures

- *Roll offset in the across-track direction* on page 173
- *Pitch offset and time delay* on page 174
- *Heading offset – Alternative 1* on page 176
- *Heading offset – Alternative 2* on page 177
- *Sound speed quality inspection* on page 178
- *Sound speed control* on page 179
- *Outer beam angle offset calibration* on page 180
- *Verification* on page 180
- *How to determine calibration values using SIS Calibration frame* on page 181
- *How to determine calibration values using SeaCal automatic calibration* on page 184
- *How to calibrate a dual head system* on page 188

Note

This section applies to multibeam echo sounders only.

To ensure maximum reliability and accuracy of the depth determination, it is strongly recommended that the system and its externally connected sensors are calibrated before the start of a new survey.

All sensors must be accurately surveyed with respect to the vessel's reference point and with respect to the vessel's reference plane during installation of the system. The attitude sensor will normally with intervals be calibrated while along a quay using land survey methods.

The intention of the SIS calibration is to find remaining biases in the installation angles and to find any time synchronization biases between the systems. The biases can originate from transducer alignment, from the alignment of the attitude sensor or be caused by time synchronization differences between the sensors.

The correct calibration of the vessel's attitude sensors as well as determining the time delay of the positioning system is vital to the quality of the depth data determined by the multibeam echo sounder.

The calibration should be performed in the following order and the values from each calibration entered in the system before the next calibration:

- Rough roll calibration
- Pitch and time delay calibration
- Heading calibration
- Roll calibration

The calibrations should be repeated until the calibration results are within ± 0.1 degree.

The built-in SIS calibration is used to process data from a calibration survey, usually consisting of one or more sets of overlapping lines as described below. It is recommended to use the SIS calibration, where depth data from two or more lines are compared. The offset values are found either by visually determining the correction values that gives best fit between the two depth curves, alternatively by using the SeaCal automatic calibration feature if licensed.

Determining a suitable calibration area

Note

Sound speed and echo sounder errors are not considered in this discussion. Sound speed must be thoroughly determined for the calibration area.

On a flat area only a roll offset will cause significant depth errors. Thus, if the survey is to be run in a reasonably flat area, it may be sufficient to perform roll calibration only. However, a full calibration is normally required. The calibration must then be carried out to eliminate influence by other errors than the one you are calibrating for.

Note that the positioning accuracy is vital for good calibration results, except for the roll error calibration on a flat bottom.

The ideal calibration area is partly flat and partly a fairly steep slope with little change in depth across-track, and with a distinct feature such as a peak or hollow in the flat area. If the heading and positioning errors are negligible, the flat area is not required if the slope has a reasonably constant depth across-track. In order to resolve the pitch offset and time delay accurately, the slope should have an appreciable relative change in depth from top to bottom of approximately 30%. Note that the slope should not be too steep, say not more than 20° , otherwise the echo sounder may have problems in maintaining good data quality.

Calibration lines

To determine any local variations across the swath, we recommend that you run calibration survey lines that covers two times the swath width.

Related operational procedures

- *Run the survey* on page 202

Parameter references

- *Calibration parameters* on page 260

Related topics

- *Calibration view* on page 100
- *SeaCal* on page 409

Roll offset in the acrosstrack direction

- 1** Choose a horizontally flat area (at least acrosstrack)
- 2** Survey two lines in opposite directions.
Ensure that sufficient lead-in time to the line is used allowing the roll sensor to stabilize.
- 3** Place a calibration corridor orthogonally to the survey lines.

Figure 9 Roll offset calibration procedure

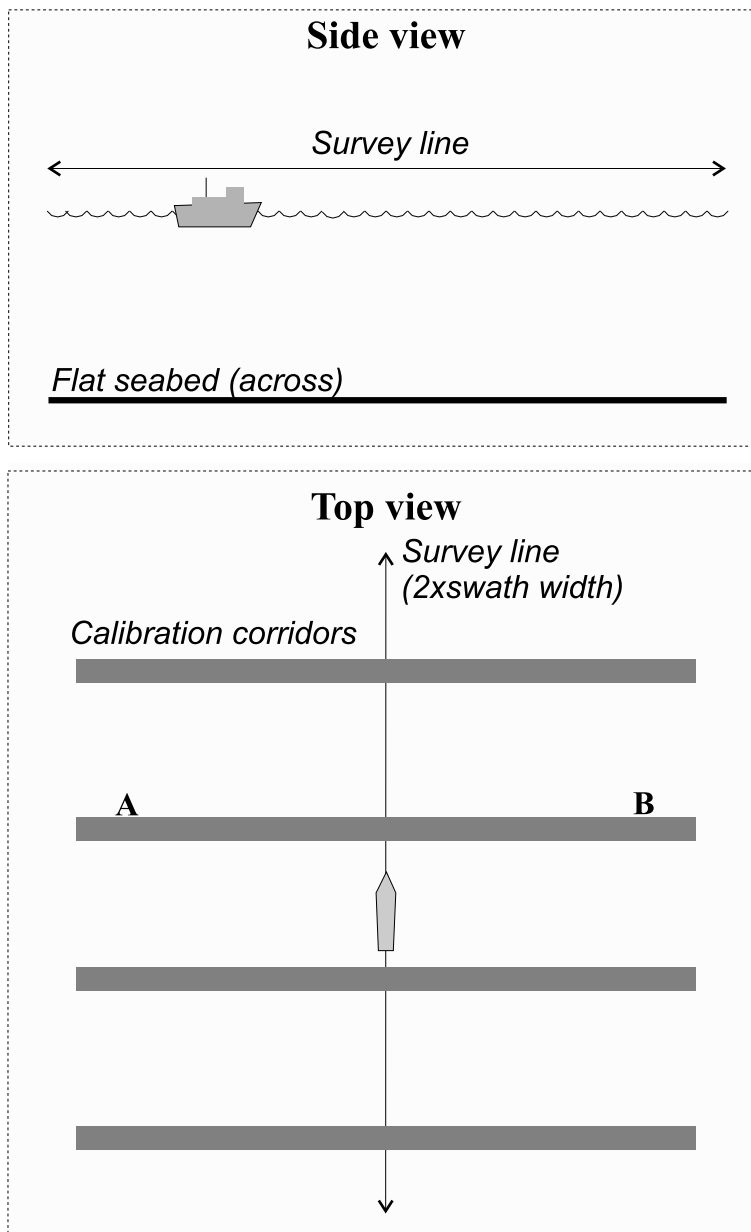

(cd022001-01)

- 4 Compare depth data from the two lines in the selected corridor.
If there is a roll offset, there will be a depth difference between the two data sets, increasing with acrosstrack distance from the centre where it is zero.
- 5 Repeat step 3 and 4, i.e. create several corridors along the calibration survey line to determine any variations over the area.

Pitch offset and time delay

- 1 Choose an area with a continuous but not too steep slope alongtrack

- 2 Survey two lines in opposite directions with constant vessel speed along each line
- 3 For time delay calibration, survey a third line on top of the two with constant, but significantly lower speed.

The direction of the last line is not essential. Ensure that sufficient lead-in time to the line is used for the pitch sensor to stabilize.

- 4 Place a calibration corridor parallel to the survey lines, on top of the vessel track

Figure 10 Pitch offset and time delay calibration procedure

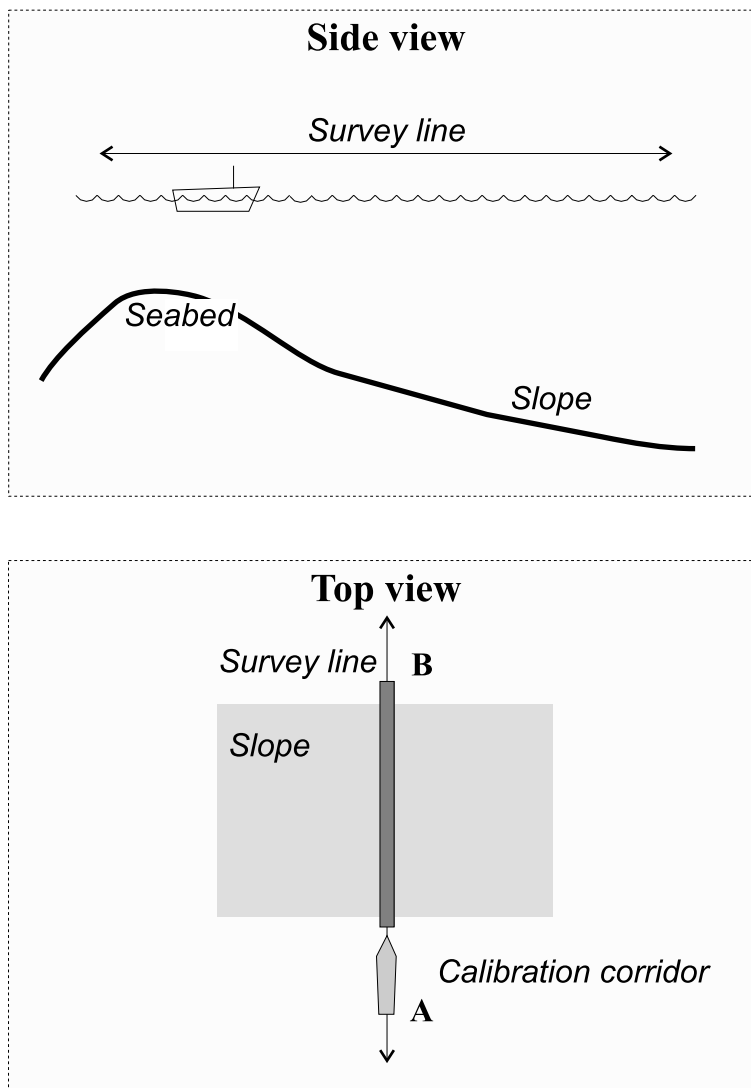

(cd022004)

- 5 Compare depth data from the two lines in the selected corridor.

Any alongtrack depth difference between the runs may be due to four different factors:

- Pitch offset

- Time delay between actual position and position when position datagram is supposed to be valid
- For multibeam echo sounders with transducers a position distance offset (either due to an error in the positioning system or an error in entered locations)
- Tide difference

6 Determine any time delay in the position system

Note that a depth error on a constant gradient slope, due to pitch offset, increases with increasing depths. Depth errors caused by position time delay increases with vessel speed, whilst errors due to distance offset is independent of depth and speed.

Comparing data from the two lines in the same direction, but with different vessel speed, will thus allow the time delay to be found.

7 Determine any pitch offset.

After the correction for time delay error has been applied to the data, the pitch offset can be determined from the two lines run in opposite directions.

Note

If PPS and time from datagram are used, there should be zero time delay. Please refer to Timing on page 498 for a detailed explanation.

Heading offset – Alternative 1

Note

The best check of the gyro is done using land survey methods while in harbour.

1 Run two parallel lines up or down a slope in the same direction, separated, but with overlap in-between.

2 Select a calibration corridor.

The corridor used for comparison must be placed alongtrack in-between the lines.

Figure 11 Heading offset calibration procedure (alternative 1)

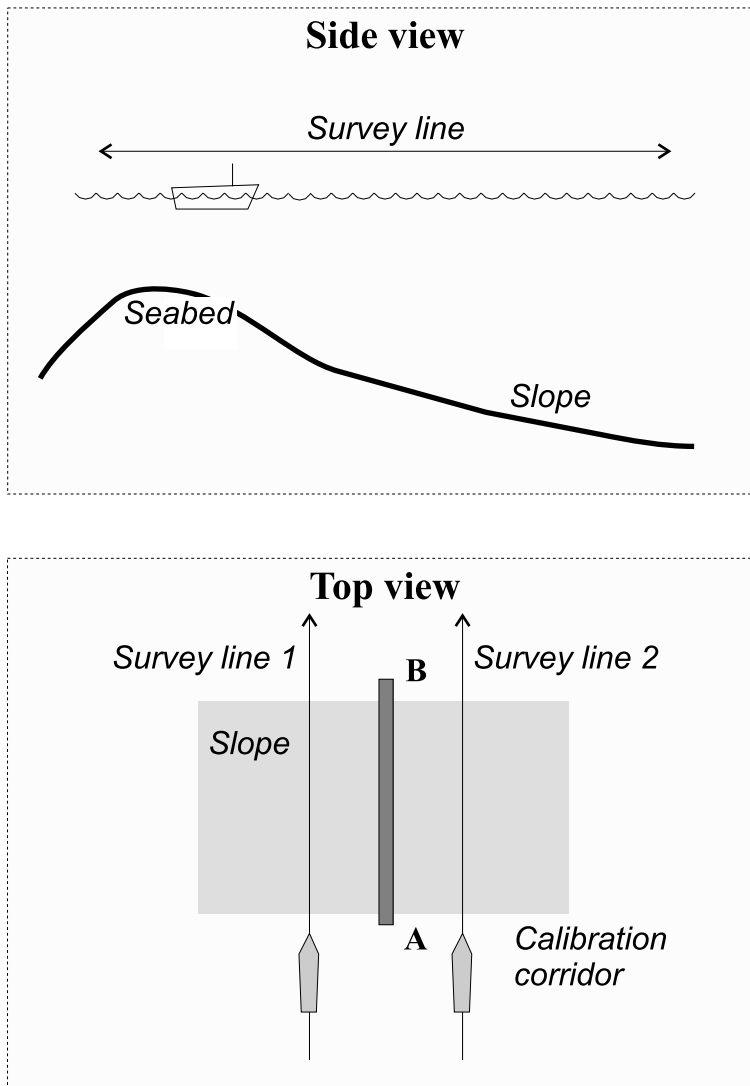

(cd022005)

- 3 Compare depth data from the two lines in the selected corridor.
Any heading offset will give a depth difference between the two lines.

Heading offset – Alternative 2

- 1 Find an easy recognizable point or feature on the bottom such as a peak or a depression.
- 2 Run two survey lines at opposite sides of this feature so that the point will be in the outer part of the echo sounder swath.
Survey these two lines in same direction.
- 3 Select a calibration corridor

The corridor used to compare data from the two survey data sets must be placed so that it intersects the feature, and is parallel to the survey lines.

Figure 12 Heading offset calibration procedure (alternative 2)

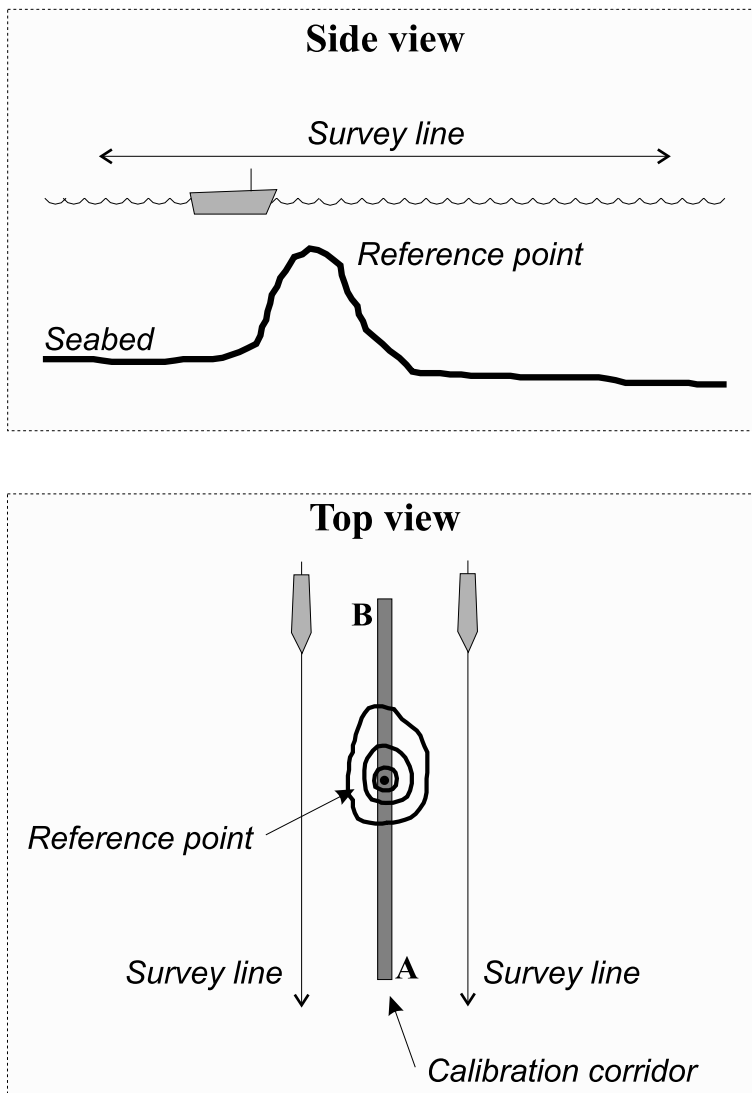

(cd022007)

- 4 Compare depth data from the two lines in the selected corridor.

If there is a heading offset, you will have a different location alongtrack in the two data sets

Note _____

Accurate positions and position time delays are required.

Sound speed quality inspection

- 1 Survey two lines or more, perpendicular to each other.

This means that the two lines in the pair cross each other on a flat area of the sea floor with a difference in the sailing direction of about 90 degrees.

- 2 Create calibration corridors in the crossover area

Figure 13 Outer beam angle calibration

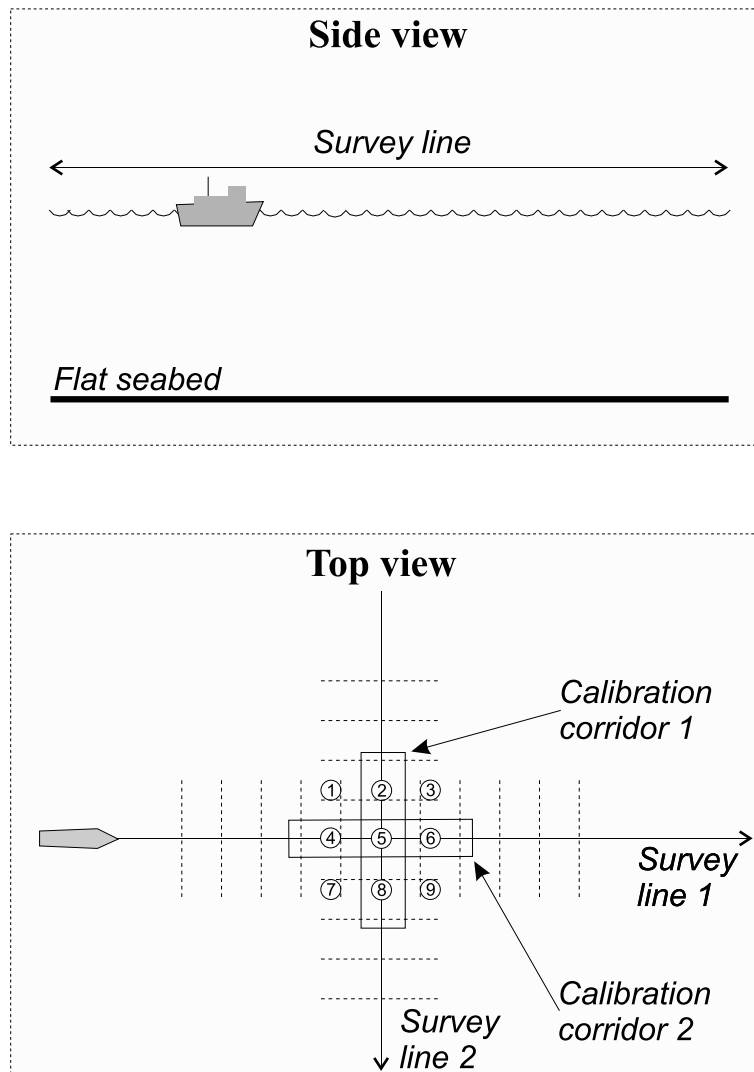

(cd022008)

- 3 Compare the depth in different points in the crossover region.

Depth differences along the two centre lines with respect to the outer edges of the swath from the other line (i.e. points 2, 4, 6, 8) will be due either to roll or sound speed errors. Note that the depth error due to sound speed has the same sign, while those due to roll changes sign across the centre line.

Sound speed control

The same procedure as used for the outer beam angle offset calibration may be used as a check for sound speed corrections. Provided that the roll offset and outer beam angle offsets are correct, any depth deviation between the two lines in the two calibration corridors are due to sound speed errors, either in the used profile, and/or in the sound speed at transducer depth.

Outer beam angle offset calibration

Please see *Outer beam angle calibration* on page 179 for a graphical description of the method.

Note

The outer beam angle offset calibration applies to EM 1002 only

Note

The outer beam angle offset is critically dependent upon correct roll calibration and correct sound speed calibration.

- 1 Run two perpendicular survey lines on a relatively flat bottom.
The depth must be approximately 50 to 100 meters, and 150 degrees coverage must be used.
- 2 Set a calibration corridor along each of the lines in the crossover area.
- 3 Compare the depth in different points in the crossover region.
Any angular error at the points 2, 4, 6 or 8 may be due to errors in:
 - Outer beam angle offset
 - Sound speed
 - Roll offset
- 4 Determine the roll offset
If sound speed and roll offset are correct, determine angular errors by changing the roll offset angle to make the outer beam depths equal at 2, 4, 6 and 8, and take the average of these.
If the outer beams are too shallow compared to the centre beams, the outer beam angle offset is positive, if they are too deep the outer beam angle offset is negative.
- 5 Add the outer beam angle offset to the outer beam angle offset already used in the installation menu.

Verification

Important

After the calibration values have been determined, we strongly advise you to repeat the procedure for verification. This is especially important if your calibration results is larger than the expected accuracy of the sensors.

Automatic calibration

SIS offers an automatic calibration using the **SeaCal** program. Calibration survey lines are as described in the procedures above. **SeaCal** will based on the selected lines compute the offset values for each parameter that gives best fit, i.e. smallest residual with highest possible reliability. **SeaCal** may be used as an alternative or as an addition to the visual method.

How to determine calibration values using SIS Calibration frame

Calibration will only work with two or more selected lines in a survey. The lines must have been surveyed according to recommended patterns. These patterns are:

- Roll calibration: parallel lines over a flat area, in opposite direction and with overlap for the outer beams
- Pitch calibration: parallel lines over a slope, in opposite direction and with lines on top of each other
- Heading calibration: parallel lines over a slope or a seabed feature, same direction and with overlap for the outer beams
- Time: same as for pitch calibration, but with different constant vessel speed for the two lines



The data used in the calibration computations is the data found inside the geographical area currently displayed in the geographical view. You may select as many lines as you want before you make your corridor. If the geographical area is set too large, or too many lines are selected, the computation may become too resource demanding for the computer. The solution is to reduce the displayed area (zoom in), or deselect some lines.

Note

Stored Shiptracks must be turned on from the Geographical Options menu.

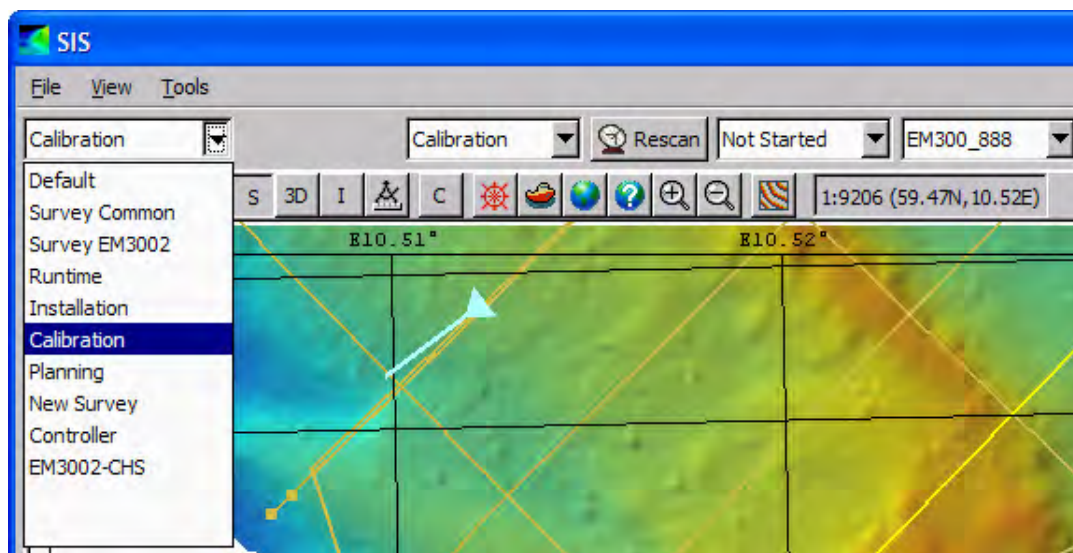
- 1 Select **Calibration** from the frame selection drop down list of the main toolbar to enable the calibration mode.



- 2 Press  from the Geographical view's toolbar to enable selection of lines and calibration corridor
- 3 Press the **Follow ship** button  to stop the view from moving along with the ship
- 4 If more than one Survey is loaded, select from the **Survey List** box which survey to use.

- 5 Select the lines by holding down the **Ctrl** button and selecting the lines using **left mouse** button.

or

select the lines by name by clicking on the **Select Lines...** button at the bottom of the **Calibration** frame.

You can check that you have picked the correct line by looking at the file name of the selected line that appears in lower left corner of the SIS application window.

Note

You may need to zoom in to be able to separate and select the correct lines

- 6 Enable selection of a **calibration corridor** to show the depth data for by holding down the **Ctrl** button and click the **right mouse** button
- 7 Select a corridor by holding down the **Ctrl** button and clicking using **left mouse** button at the two end points of the selected line

Data from two or more lines inside this corridor will be analysed.

- For roll calibration – select a corridor across the two survey lines
- For pitch calibration – select a corridor along the survey lines
- For heading calibration – select a corridor along the survey lines
- For timing calibration – select a corridor along the survey lines

When a corridor has been selected, the calibration module will read the raw depth and display them in a diagram.

- 8 Make sure the depth data for the selected survey lines along the selected corridor is displayed in the **Calibration** frame.

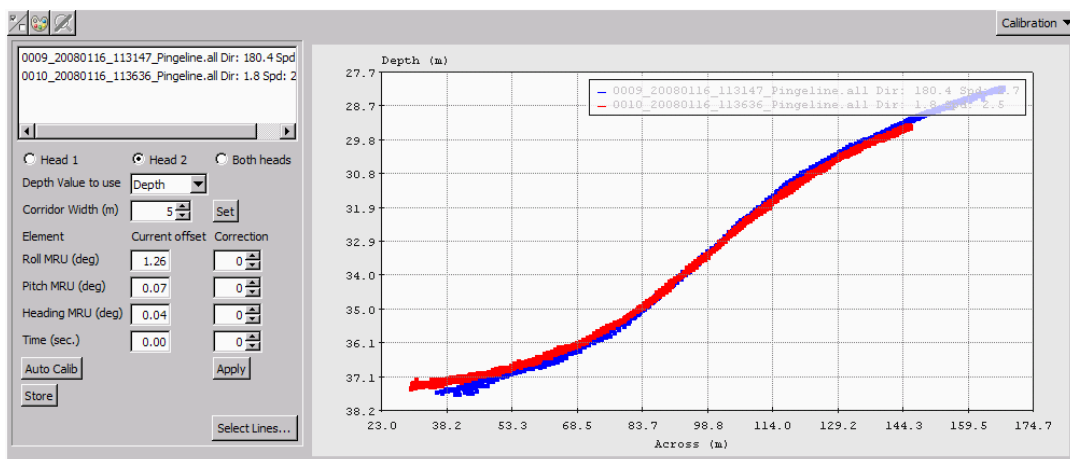

The system will use data within the corridor, which represents all points within a specified distance from a calibration line. The data will be displayed using a two-dimensional diagram with the horizontal axis representing the distance along the corridor, and depth along the vertical axis. Data from two different survey lines will be shown in the same diagram, each with its own colour.

In the Calibration window you can change the offset value of the sensor you are calibrating and immediately see its effect on the depths shown. The offset value giving the best fit between the curves is the result of the calibration.

Note

*The offsets applied in the selected files are shown as **Current Offset**. These are not necessarily the current ones in the Installation parameters. Take care to check that the lines used for calibration have been run with the same parameters as the current ones in the Installation parameters*

- 9 If you have dual head, select what head you want to calibrate.
- 10 Enter an estimated correction value for the sensor you are calibrating, i.e. either roll, pitch, heave or time
The values can be increase/decreased by using the spin buttons.
- 11 Press **Apply** to calculate and display the effect on the depth curves
- 12 Iterate through step 9 and step 10 until you find the value that gives best visual fit between the two depth curves
The offset value that gives the best fit between the depths on the two calibration lines is finally to be entered in the corresponding sensor field in the system's **Installation parameters**.
- 13 Repeat step 7 to step 12 placing the corridor at different places along the calibration lines.
- 14 Ensure that you have consistent calibration values along the line before you apply any calibration values to the installation parameters.
If there is significant inconsistency along the line you must evaluate what may be causing the inconsistency, and what you can do to correct for them. The reason for inconsistency may be:
 - Variation in sound speed over the area.
 - Unreliable position and motion observations
 - Remaining errors in the installation angles

Note

The Seacal calibration as described in the following can be used to verify any suspected inconsistency along the calibration line. Seacal will automatically look for consistency along the whole calibration line, and label the results as unreliable if they are inconsistent.

- 15 Press **Store** to add the new values to the existing ones that are set from **Installation parameters**→**Sensor setup**→**Angular offset**
and/or
- 16 Open the **Installation parameters** frame and select **Sensor setup**→**Angular offset**.
- 17 Verify the newly stored values, or manually enter your new calibration figures.

Note

To verify that correct values have been automatically entered you must know the original figures, which not necessarily were zeros.

For single head systems the values are to be applied to the **Attitude** sensor in use.

For dual head systems you have to enter the values manually.

For dual head system we recommend that you apply the average value for head 1 and 2 on the attitude sensor, and the difference from the average on each of the sonar heads. I.e. if the results for head 1 and 2 are +0.3 and +0.5, respectively, we recommend that you apply +0.4 on the attitude sensor and -0.1 and +0.1 on sonar head 1 and 2.

- 18 Press **OK** to download the new values to the echo sounder.
- 19 Verify the calibration results by rerunning the calibration procedure step 1 to step 13.
If the calibration was successful, the new correction values will be close to zero.

Parameter references

- *Angular Offsets for EM 2040* on page 290

Related topics

- *Calibration view* on page 100
- *Keyboard and mouse in the Calibration view* on page 46

How to determine calibration values using SeaCal automatic calibration

Automatic calibration requires two or more selected lines that have been surveyed according to patterns described earlier in this chapter. The lines may be the same as you have used for visual determination of calibration values as described in *How to determine calibration values using SIS Calibration frame* on page 181. If you already have selected your calibration lines you do not have to repeat it.

SeaCal will use all available data within what is currently displayed inside the geographical view. By panning and zooming you may select the optimal area for the calibration computations. If the geographical area is set too large, or too many lines are selected, the computation may become too resource demanding for the computer. The solution is to reduce the displayed area (zoom in), or deselect some lines.

- 1 Select the lines by holding down the **Ctrl** button and selecting the lines using **left mouse** button.

You can check that you have picked the correct line by looking at the file name of the selected line that appears in lower left corner of the SIS application window.

Note

You may need to zoom in to be able to separate and select the correct lines

- 2 Zoom back to a view showing the complete length of the lines.

If not, only data from the view will be used in the computation.

3 Select what head you are calibrating.

Note

*If you have a dual head system you are allowed to calibrate both heads in one computation. Select **Both heads** to calibrate both heads.*

4 Press the **AutoCalib** button

Parameter	On/Off	Initial Value(s)
Roll	<input checked="" type="checkbox"/>	0
Pitch	<input type="checkbox"/>	0
Heading	<input type="checkbox"/>	0
X0	<input type="checkbox"/>	0
Y0	<input type="checkbox"/>	0
Roll Scale	<input type="checkbox"/>	0
Y-Scale	<input type="checkbox"/>	0
Relative Tide	<input checked="" type="checkbox"/>	
Beam Sector	<input checked="" type="checkbox"/> All	0 90
Maximum sea depth	<input checked="" type="checkbox"/> All	12000
Resolution	<input checked="" type="checkbox"/> Auto	0
Max iterations	<input checked="" type="checkbox"/> Auto	20

Type of computation

Calibration

Calibration with Reliability test

Accept Cancel

5 Tick off for the element you are calibration, i.e. either roll, pitch or heading. Further, we recommended to tick off for the following options:

- Relative Tide: All
- Beam Sector: All
- Maximum sea depth: All
- Resolution: Auto
- Max iterations: Auto

Leave the remaining parameters unchecked.

6 Set **Type of computation** to **Calibration with Reliability test**

7 Press **Accept** to start the computations

Depending on the data consistency there will be a number of iterations carried out. You may follow the iteration process in a command window appearing.

When completed windows showing the reliability of the computed values are shown for each head. The graph shows how well Seacal is able to compute the calibration value. The reliability indicator, R, should be as close to 1.0 as possible.

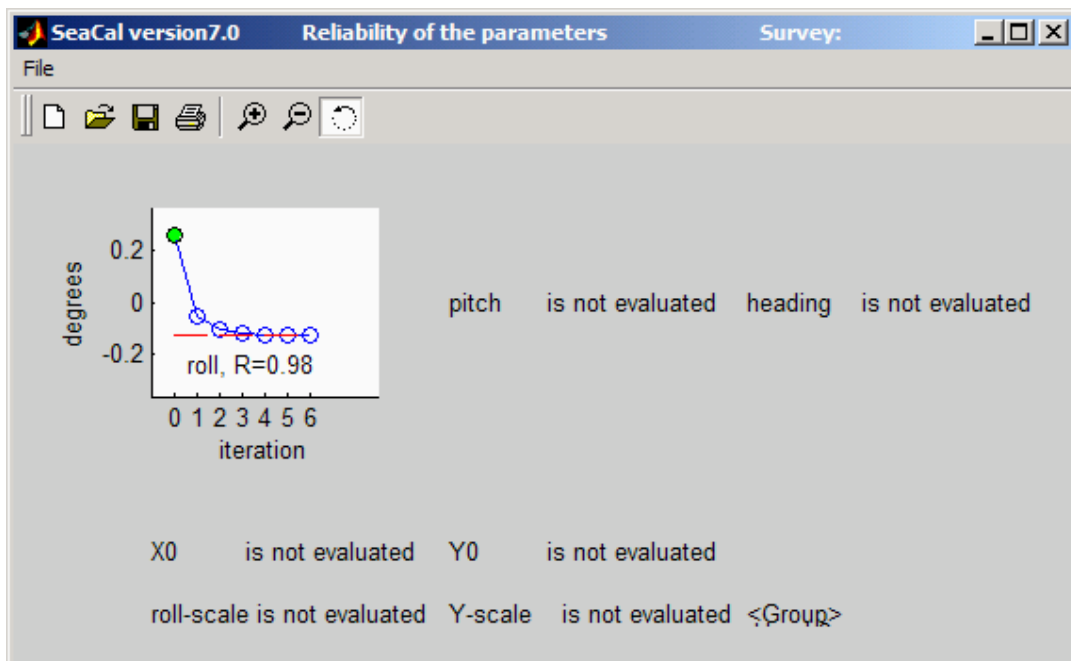

- 8 Close the reliability windows
The window **Open SeaCal result file** appears.

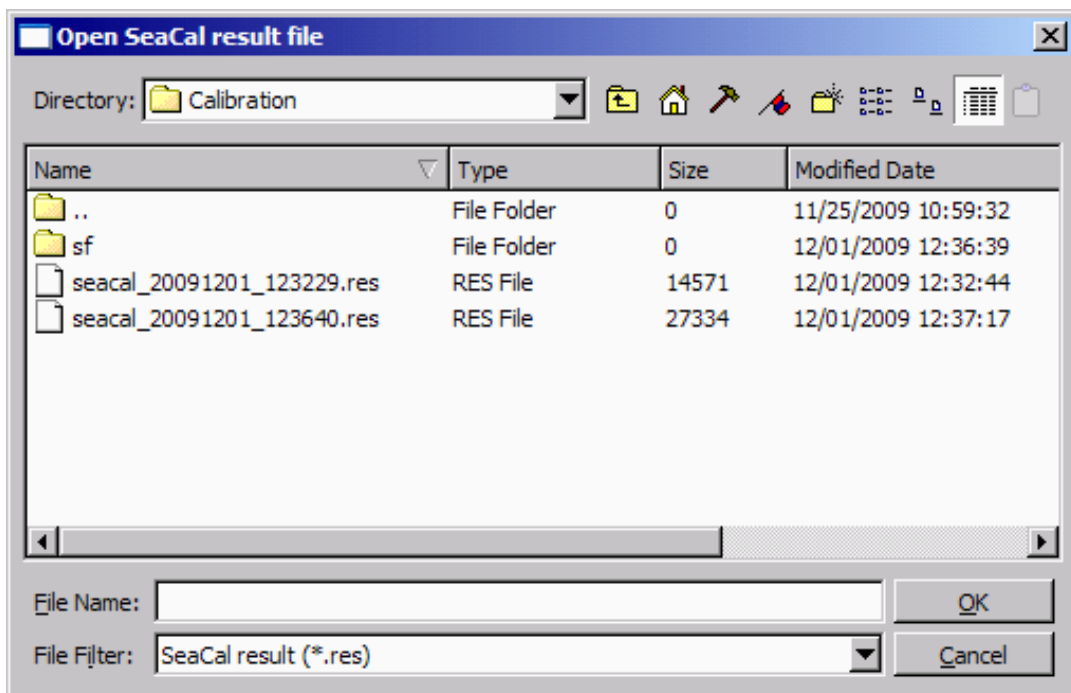

- 9 Open the *.res file. The filename of the result file has the format `Seacal_yyyymmdd_hhmmss.res`, where `yyymmdd` is date of computation and `hhmmss` is local time of computation.

Note

For dual head systems the result file will contain the results for both heads.

The **SeaCal Results** window will appear. In example below roll has been calibrated giving the following results:

- Roll calibration value = 0.879/-0.129, i.e. the correction value that may be applied to head 1 and head 2, respectively
- Correlation = 0.00

The correlation coefficient gives information about how well the parameters can be separated. Values below 0.3 is labelled OK.

- Reliability = 0.00/0.98, i.e. close to 1, which is best achievable figure for reliability

The result values for roll are labelled with green label, which means results are consistent and considered to be reliable.

The screenshot shows a window titled "SeaCal Results" with a table of parameters. The table has columns for Parameter, Value, Correlation, Reliability, Status, and Sigma. The "Roll" parameter is highlighted with a green status indicator, while others are red. A legend at the bottom explains the status indicators: green for OK, yellow for Evaluate, and red for Evaluation strongly recommended.

Parameter	Value	Correlation	Reliability	Status	Sigma
Roll	0.879 / -0.129	OK -0.00 / -0.00	0.00 / 0.98		0.044 / 0.001
Pitch	-0.000 / -0.000	OK 0.00 / -0.00	0.00 / 0.00	fixed	0.000 / 0.000
Heading	0.000 / 0.000	OK -0.00 / 0.00	0.00 / 0.00	fixed	0.000 / 0.000
X0	0.00 / 0.00	OK -0.00 / 0.00	0.00 / 0.00	fixed	0.00 / 0.00
Y0	0.00 / 0.00	OK -0.00 / 0.00	0.00 / 0.00	fixed	0.00 / 0.00
H0	-0.00 / -0.00	OK 0.00 / 0.00	0.00 / 0.00	fixed	0.00 / 0.00
Roll Scale	0.00000 / -0.00000	OK -0.00 / -0.00	0.00 / 0.00	fixed	0.00000 / 0.00000
Y-Scale	-0.00000 / 0.00000	OK -0.00 / -0.00	0.00 / 0.00	fixed	0.00000 / 0.00000

Legend: ● OK ● Evaluate ● Evaluation strongly recommended

- 10 Press OK to finish.

Note

*No corrections are applied. Correction values must be entered into **Angular Offsets** set in the **Installation Parameters** frame*

Note

*To review the SeaCal results, select **Tools**→**Seacal Results** from the SIS main menu*

Related operational procedures

- *How to determine calibration values using SIS Calibration frame* on page 181

Parameter references

- *Seacal auto calibration* on page 261
- *SeaCal results* on page 381

Related topics

- *SeaCal* on page 409

How to calibrate a dual head system

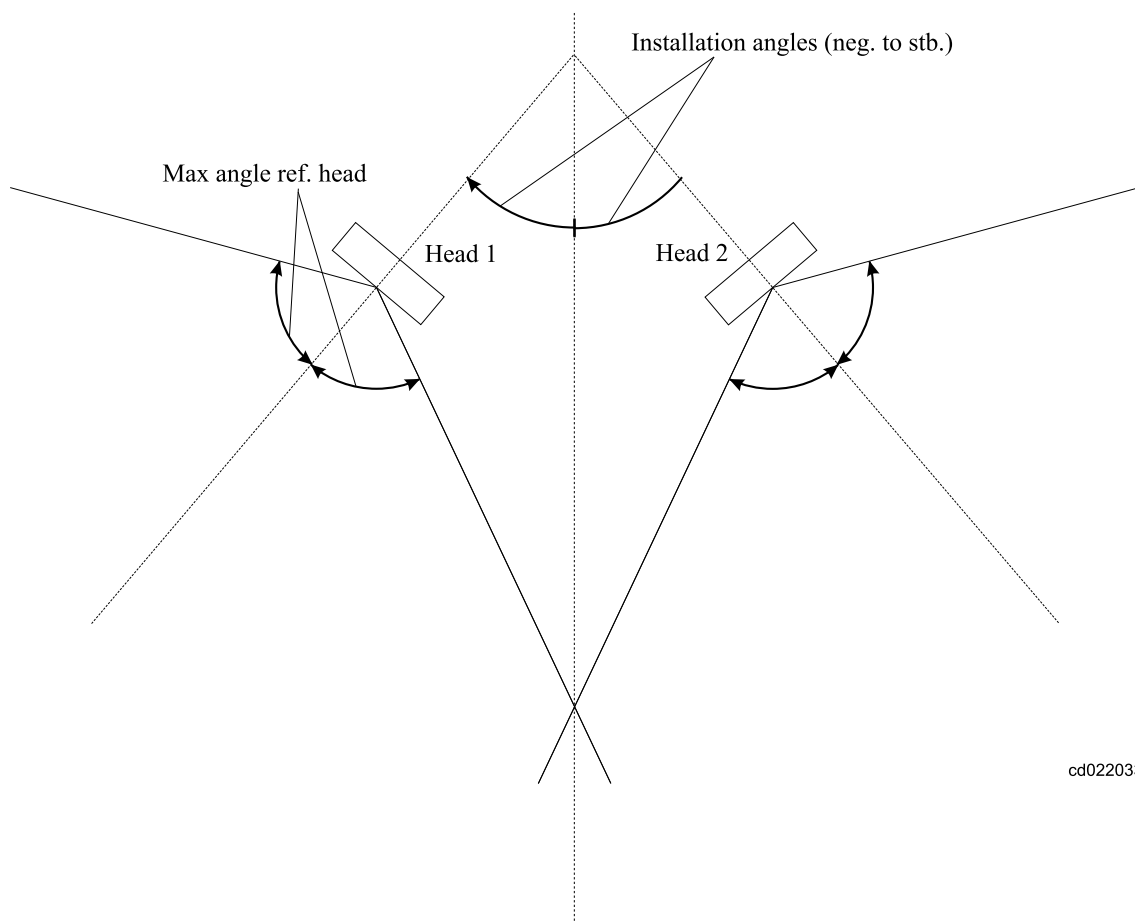

If you have a multibeam echo sounder with two heads installed there are some additional concerns related to calibration you need to consider:

- You have to determine offset values separately for both heads
- The heads will normally be installed pointing sideways instead of down calling for a different calibration survey pattern

Note

A valid sound velocity profile must be used to obtain a correct result.

The calibration should be performed in the following order and the values from each calibrations entered in the system before the next calibration:

- Rough roll calibration
- Pitch and time delay calibration
- Heading calibration
- Roll calibration

The calibrations should be repeated until the calibration results are within ± 0.1 degree.

Use the SIS Calibration frame and/or the Seacal automatic calibration to evaluate the data and determine the offset value. See

- *How to determine calibration values using SIS Calibration frame* on page 181
- *How to determine calibration values using SeaCal automatic calibration* on page 184

Roll offset calibration – dual head

- 1 Choose a horizontally flat area (at least across track)
- 2 Survey three lines in opposite directions and with distance between the lines to ensure full overlap for each head, i.e approximately half the swath width. Survey these lines at the same speed.
Ensure that sufficient lead-in time to the line is used allowing the roll sensor to stabilize.
- 3 Select two of the lines.
Select the lines that gives full overlap for one of the heads.
- 4 Place a calibration corridor (A) orthogonally to the survey lines.

Figure 14 Roll offset calibration procedure

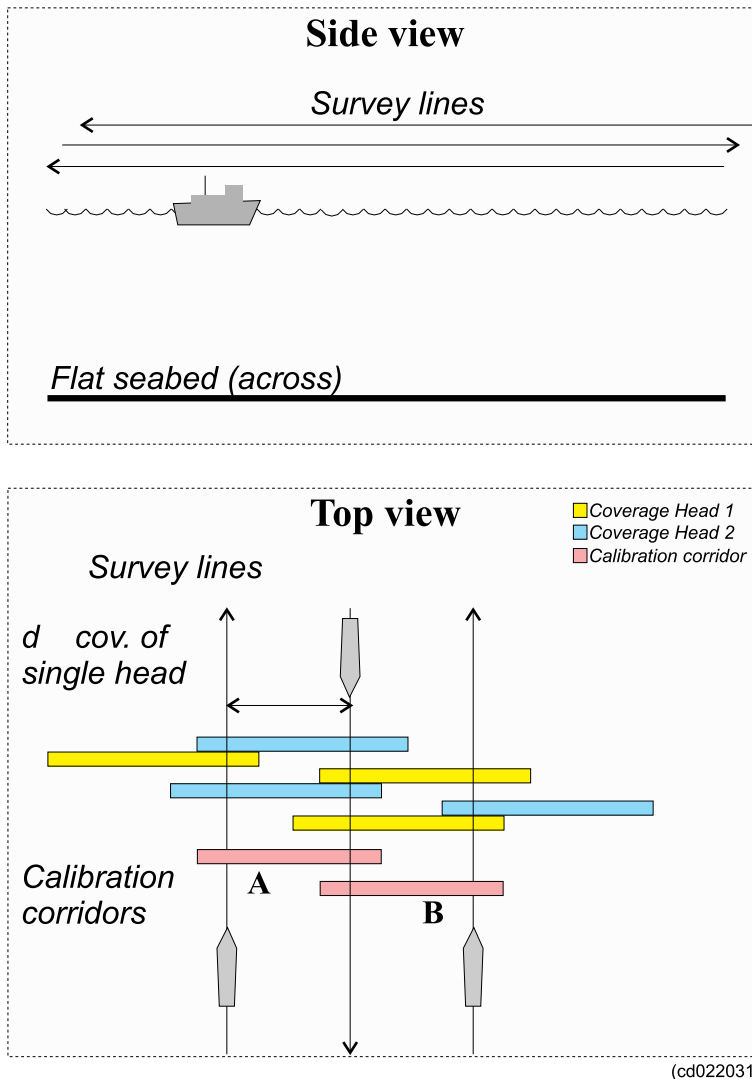

- 5 Compare depth data from the two lines in the selected corridor.
If there is a roll offset, there will be a depth difference between the two data sets, increasing with acrosstrack distance from the centre where it is zero.
- 6 Select two of the lines that gives full overlap for the other head.
- 7 Place a calibration corridor (B) orthogonally to the survey lines.
- 8 Compare depth data from the two lines in the selected corridor.
If there is a roll offset, there will be a depth difference between the two data sets, increasing with acrosstrack distance from the centre where it is zero.

Pitch offset calibration – dual head – Alternative 1

Preparations: Reduce the opening angle to ± 50 degrees on the outer sectors. Open the inner angle to ± 20 degrees on the inner sectors.

- 1 Choose an area with a continuous, but not too steep, slope alongtrack.

- 2 Survey two lines in opposite directions with constant vessel speed along each line. Survey these lines at the same speed.
- 3 For time delay calibration, survey a third line on top of the two with constant, but significantly lower speed.

The direction of the last line is not essential. Ensure that sufficient lead-in time to the line is used for the pitch sensor to stabilize.

- 4 Place a calibration corridor parallel to the survey lines, on top of the vessel track.

Figure 15 Pitch offset and time delay calibration procedure, alternative 1

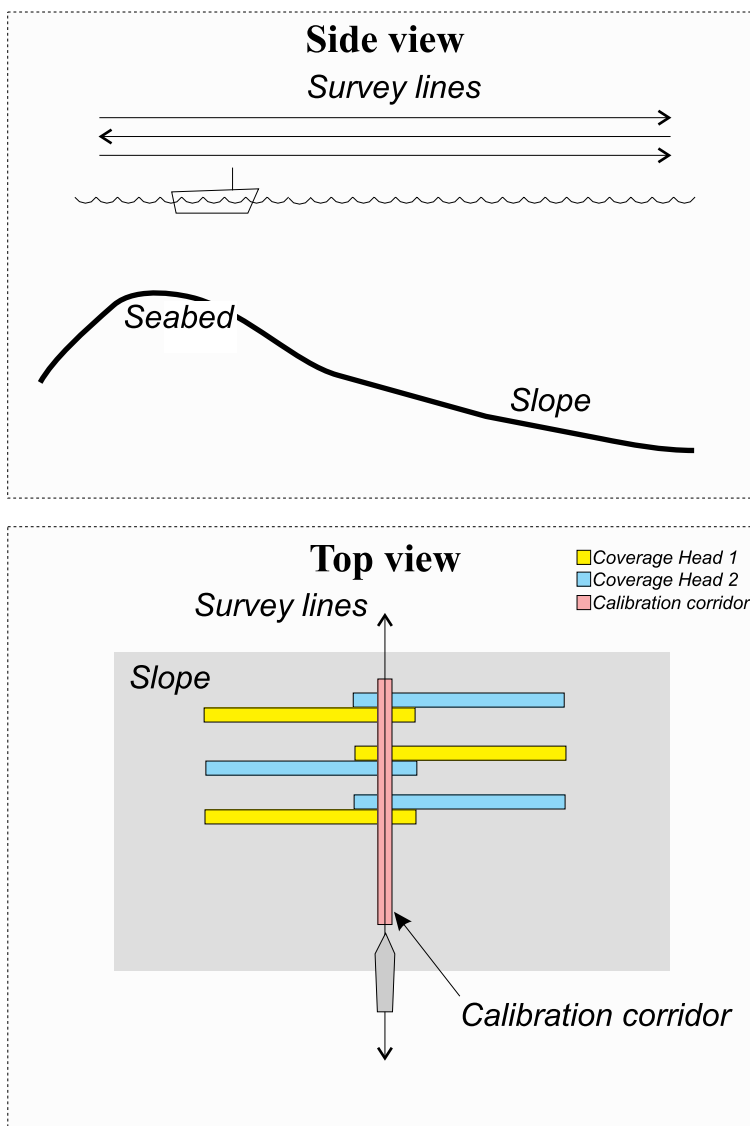

(cd022040)

- 5 Compare depth data from the two lines in the selected corridor. Any alongtrack depth difference between the runs may be due to four different factors:
 - Pitch offset

- Time delay between actual position and position when position datagram is supposed to be valid
- For multibeam echo sounders with transducers a position distance offset (either due to an error in the positioning system or an error in entered locations)
- Tide difference

6 Determine any time delay in the position system

Note that a depth error on a constant gradient slope, due to pitch offset, increases with increasing depths. Depth errors caused by position time delay increases with vessel speed, whilst errors due to distance offset is independent of depth and speed.

Comparing data from the two lines in the same direction, but with different vessel speed, will thus allow the time delay to be found.

7 Determine any pitch offset.

After the correction for time delay error has been applied to the data, the pitch offset can be determined from the two lines run in opposite directions.

Pitch offset calibration – dual head – Alternative 2

Preparations: Reduce the opening angle to ± 50 degrees on the outer sectors. Open the inner angle to ± 20 degrees on the inner sectors.

- 1** Find an easy recognizable point or feature on the bottom such as a peak or a depression.
- 2** Survey two lines in opposite directions with constant vessel speed across the feature. Survey these lines at the same speed.
- 3** For time delay calibration, survey a third line on top of the two with constant, but significantly lower speed.

The direction of the last line is not essential. Ensure that sufficient lead-in time to the line is used for the pitch sensor to stabilize.

- 4** Place a calibration corridor parallel to the survey lines, on top of the vessel track.

Figure 16 Pitch offset and time delay calibration procedure, alternative 2

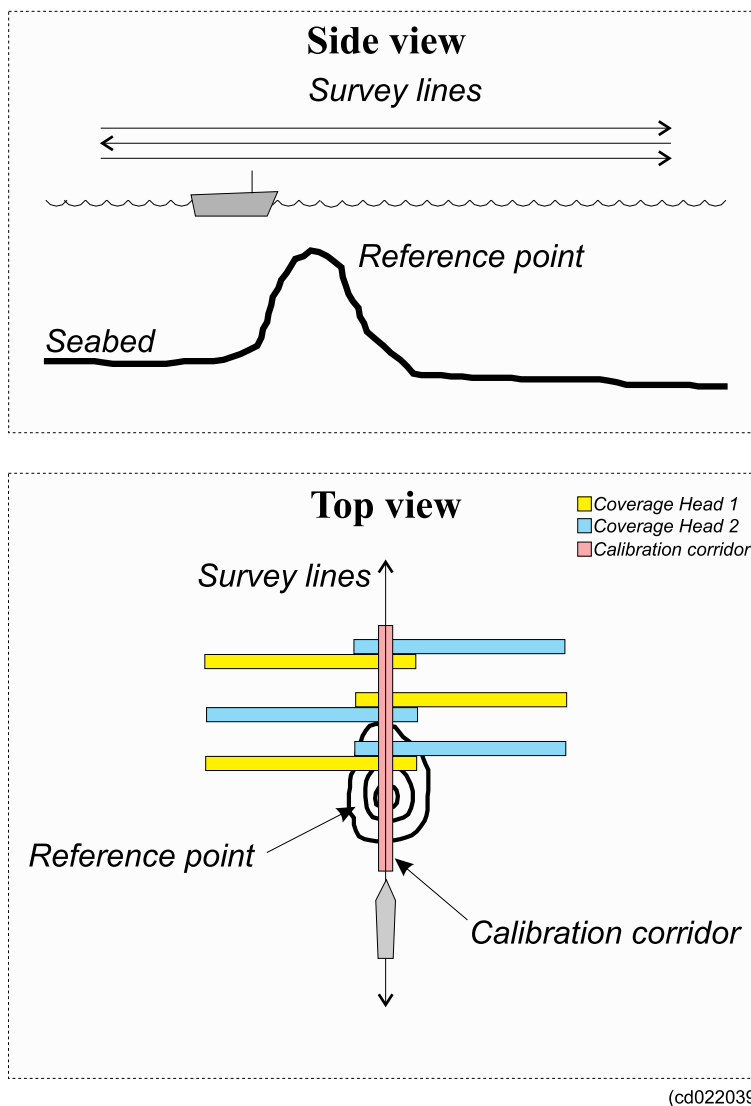

5 Compare depth data from the two lines in the selected corridor.

Any alongtrack depth difference between the runs may be due to four different factors:

- Pitch offset
- Time delay between actual position and position when position datagram is supposed to be valid
- For multibeam echo sounders with transducers a position distance offset (either due to an error in the positioning system or an error in entered locations)
- Tide difference

6 Determine any time delay in the position system.

Comparing data from the two lines in the same direction, but with different vessel speed, will thus allow the time delay to be found.

7 Determine any pitch offset.

After the correction for time delay error has been applied to the data, the pitch offset can be determined from the two lines run in opposite directions.

Heading offset calibration – dual head – Alternative 1

Note _____

The best check of the gyro is done using land survey methods while in harbour.

- 1 Run two parallel survey lines up or down a slope in the same direction, separated, but with overlap in-between. Survey these lines at the same speed.
- 2 Place a calibration corridor on top of one of the survey lines:

Figure 17 Heading offset calibration procedure – dual head alternative 1

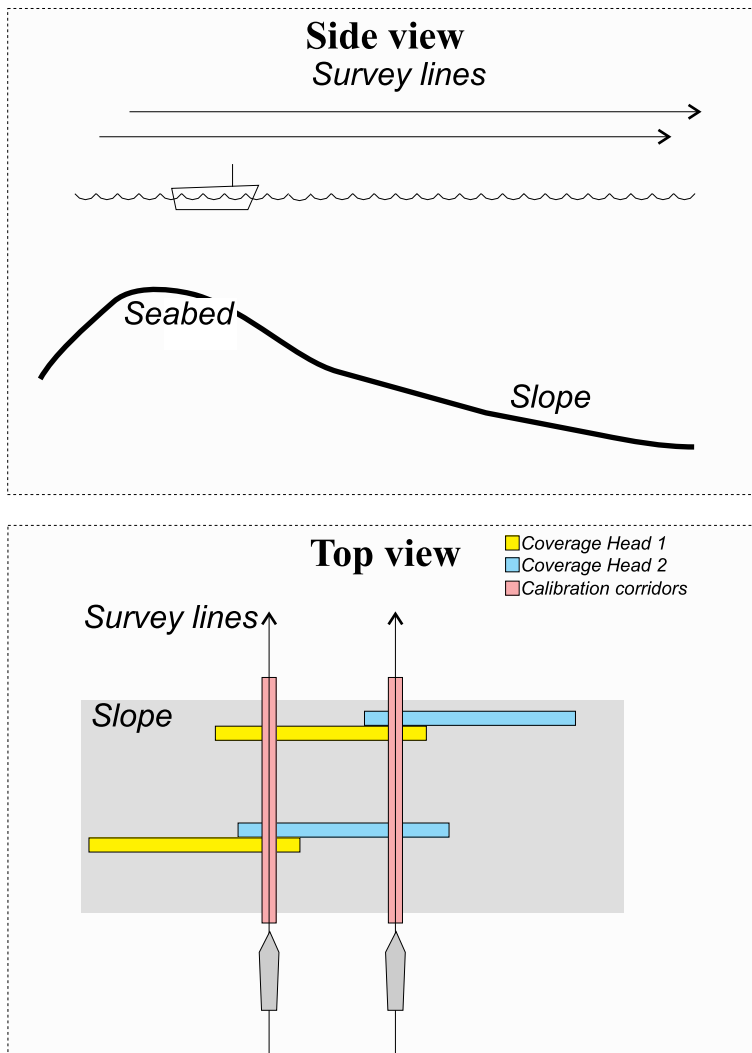

(cd022032-02)

- 3 Compare depth data from the two lines in the selected corridor.

Any heading offset will give a depth difference between the two lines.

- 4 Repeat step 2 and 3, i.e. create a calibration corridor on top of the other survey line to compare data for the other head.

Heading offset calibration – dual head – Alternative 2

- 1 Find an easy recognizable point or feature on the bottom such as a peak or a depression.
- 2 Run three survey lines, one on each side of the feature, and one on top of it. Survey these three lines in same direction and at the same speed.

The lines should be separated, but with overlap in-between.

- 3 Place a calibration corridor on the survey line on top of the object.

Figure 18 Heading offset calibration procedure – dual head alternative 2

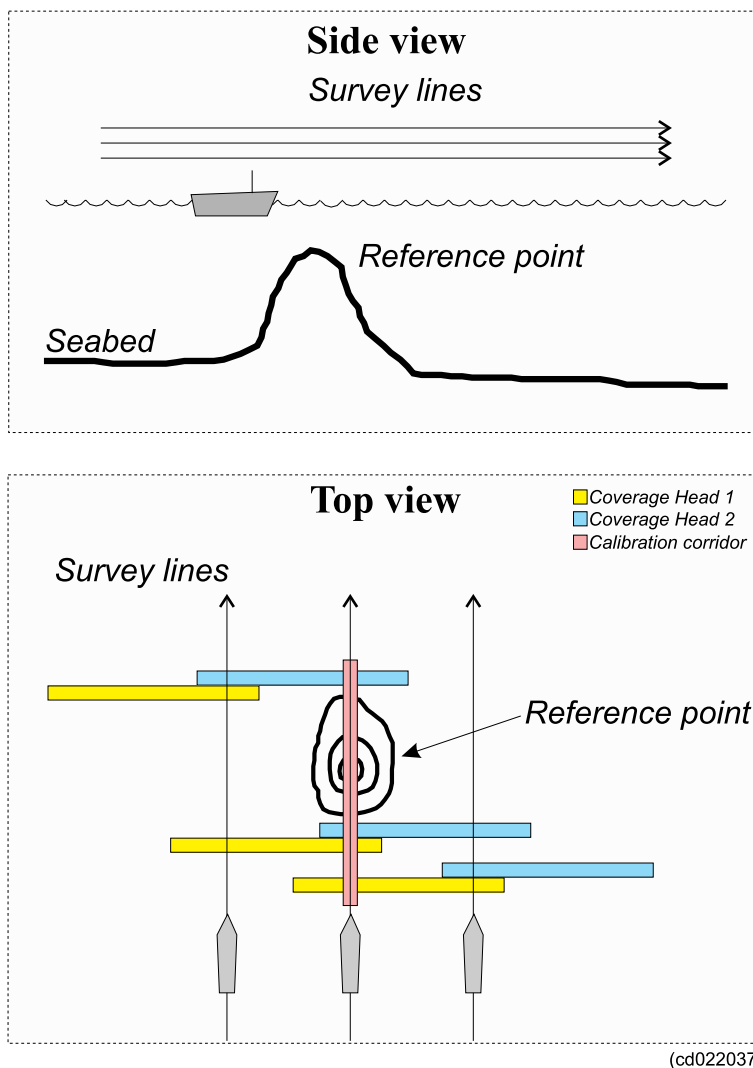

- 4 Compare depth data from the line in centre with the lines on each side of the object. Any heading offset will give a depth difference between the two lines.

Example 1 Roll calibration – changing the installation parameters

Original installation parameters:

	Roll	Pitch	Heading
Sonar head 1:	40.0	2	359.5
Sonar head 2:	-40.0	2.2	1.75
Attitude 1, COM2/UDP5:	0.0	0.00	0.00
Attitude 2, COM3/UDP6:	0.00	0.00	0.00
Stand-alone Heading:			0.00

Roll calibration result:

- Head 1: 0.2 degrees
- Head 2: 0.4 degrees

Corrections:

A Mean value for attitude sensor: $(0.2 + 0.4) / 2 = 0.3$

B Correction for head 1: $0.2 - 0.3 = -0.1$

Value to enter in installation parameters: $40 + (-0.1) = 39.9$

C Correction for head 2: $0.4 - 0.3 = 0.1$

Value to enter in installation parameters: $-40 + 0.1 = -39.9$

	Roll	Pitch	Heading
Sonar head 1:	39.9		359.5
Sonar head 2:	-39.9		1.75
Attitude 1, COM2/UDP5:	0.3	0.00	0.00
Attitude 2, COM3/UDP6:	0.00	0.00	0.00
Stand-alone Heading:			0.00

Example 2 Pitch calibration – changing the installation parameters

Original installation parameters:

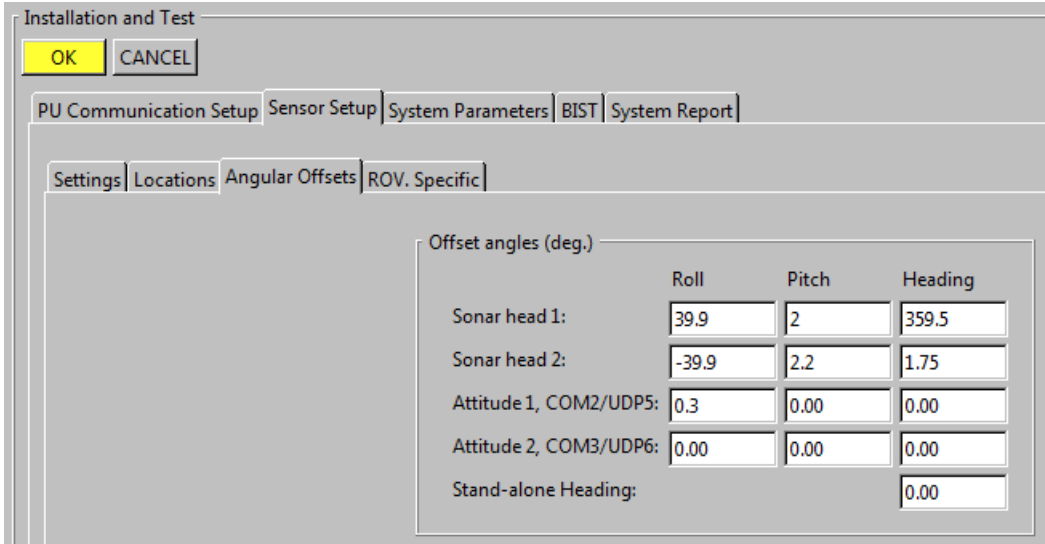

Pitch calibration result:

- Head 1: 0.2 degrees
- Head 2: -0.4 degrees

Corrections:

- A** Mean value for attitude sensor: $(0.2 + (-0.4)) / 2 = -0.1$
- B** Correction for head 1: $0.2 - (-0.1) = 0.3$
Value to enter in installation parameters: $2 + (0.3) = 2.3$
- C** Correction for head 2: $-0.4 - (-0.1) = -0.3$
Value to enter in installation parameters: $2.2 + (-0.3) = 1.9$

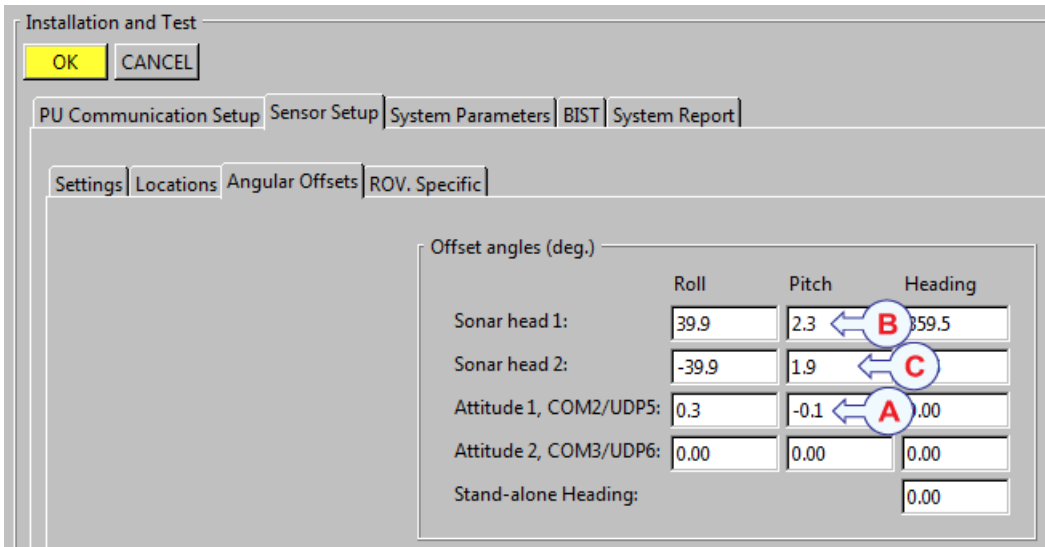

Example 3 Heading calibration – changing the installation parameters

Original installation parameters:

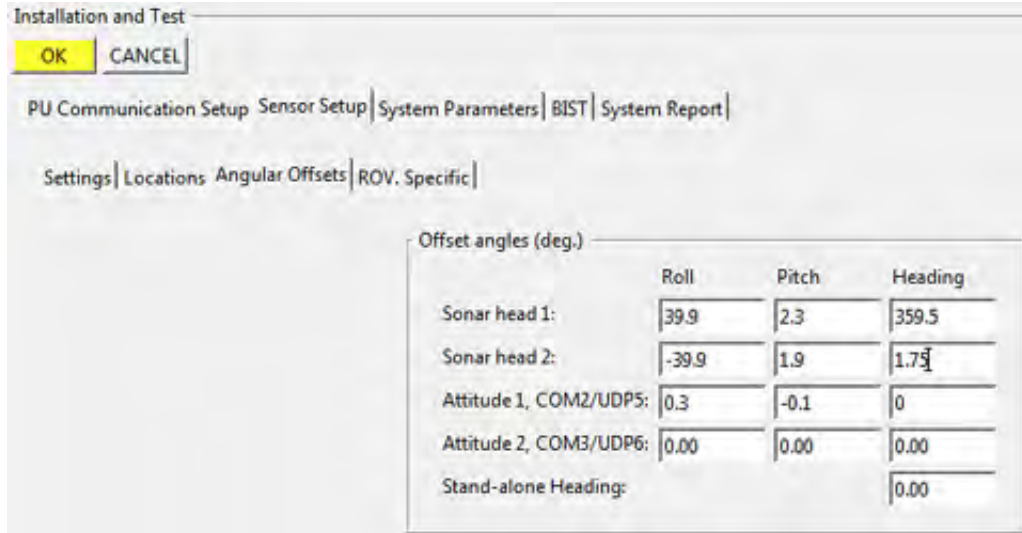

Heading calibration result:

- Head 1: 0.342 degrees
- Head 2: -2.240 degrees

Corrections:

- A** Mean value for attitude sensor: $(0.342 + (-2.240))/2 = -0.949$ degrees
- B** Correction value for head 1: $0.342 - (-0.949) = 1.291$ degrees
Value to enter in installation parameters: $359.5 + 1.291 = 360.791$
 $360.791 - 360 = 0.791$ degrees
- C** Correction value for head 2: $-2.240 - (-0.949) = -1.291$ degrees
Value to enter in installation parameters: $1.75 - 1.291 = 0.459$ degrees

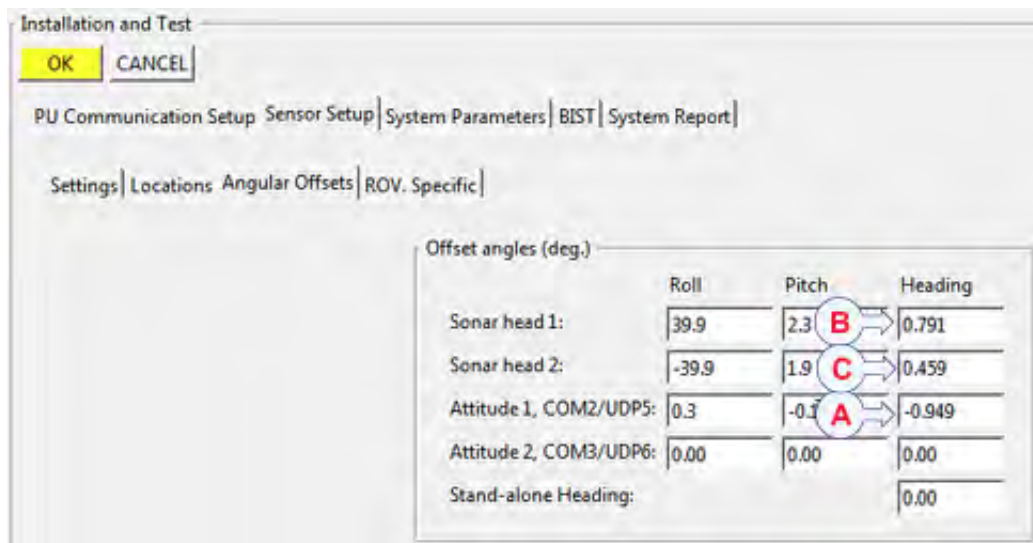

Related operational procedures

- *How to determine calibration values using SIS Calibration frame* on page 181
- *How to determine calibration values using SeaCal automatic calibration* on page 184

Parameter references

- *Calibration parameters* on page 260
- *Seacal auto calibration* on page 261
- *SeaCal results* on page 381

Related topics

- *SeaCal* on page 409

Plan a survey

Introduction

A survey plan will normally define the following factors:

- The survey area
- Bottom conditions
- The survey lines
- The direction and order of the survey lines
- The survey lines required for system calibration
- The location and timing for sound speed profiles

When planning the survey lines islands, coastlines, shoals and other obstacles within the survey area that may have influence on safety or efficiency of the survey must be taken into account. The achievable coverage of the multibeam echo sounder and the overlap required between neighbouring lines is usually used to determine the line spacing.

A fully comprehensive survey plan is most useful in areas of deep waters or where the depth and hence coverage is fairly constant. In shallow waters where the depth changes rapidly and may not even be known, a comprehensive plan may not be as useful, especially if the survey is to be run with a small and agile vessel. A defined survey area boundary plus a few pre-planned lines for calibration may then be enough. Actual coverage is obtained on the spot instead of being used to determine the survey lines.

The SIS Planning module allows a survey to be split into sub-surveys or jobs. The survey area boundary may be defined as a polygon with any number of corners, as may areas which are not to be entered. Automatic line clipping at the polygon boundaries and automatic generation of parallel lines is supported.

During the survey, planned lines may be activated to generate steering information for the bridge and helmsman's display. The purpose of the Planning module is thus to provide help before and during the survey.

Factors to consider

- A survey is normally planned taking the following into account:
 - Echo sounder coverage
 - Seafloor topography
 - Sound speed variations
 - Weather conditions
- The requirements for calibration of the positions (time delay), heading, roll and pitch sensors must be considered, and how and where to gather sound speed profiles.
- Coverage capability determines line spacing, and as it varies with bottom reflectivity, this must be estimated. Usually 10% overlap between lines is sufficient, but if large variations in bottom reflectivity is expected, or reflectivity is unknown, it may be necessary to increase the overlap. The overlap must also be increased if the vessel's roll is excessive.
- If there are steep slopes on the bottom, it is strongly advised to run along these slopes, not up or down them. This is beneficial for keeping coverage reasonably constant along the survey lines, thus making survey planning easier. However, the main reason for this advice is that the echo sounder performance will usually be poorer when running up or down a slope rather than along. This is because less acoustic energy is reflected towards the transducer from steep slopes, causing poorer detections and the possibility of false detections in sidelobes. Sidelobe detections is however very rare in the Kongsberg multibeam echo sounders due to the advanced signal processing implemented. Note that if circumstances require that survey lines are run up or down a slope, reduction of vessel speed may be required to allow the echo sounder to track the bottom continuously.
- Coverage capability is also affected by weather conditions and possibly also by vessel speed. Heavy seas and possibly vessel speed lead to increased noise level, and may also cause aeration on the Sonar Head or the transducer array.
- Aeration is a function of sea state, but also of the heading with respect to the wave direction and the vessel speed. It is strongly advised that one builds a record of coverage and aeration problems versus sea state, heading with respect to wave direction, and vessel speed. This record may be helpful in ensuring that surveys can be performed efficiently with a minimum of line rejections and corresponding reruns and infills.
- Any drift rates of roll, pitch and heading should also be recorded to enable efficient planning of calibration intervals. If calibration is required before a survey, a suitable calibration area must be identified before reaching the survey area.
- A sound speed profile must always be taken within the survey area and loaded into SIS before the survey is started. In some areas the profile will vary, mostly due to fresh water inflows from rivers or currents from areas with different salinity. Surface sound speed variation may be strongly affected by solar warming. If variations can be expected, where and when sound velocity profiles are to be taken must be planned, and the survey line schedule adjusted to take this into account.
- If the measured sound speed value at the Sonar Head or the transducer array depth is continuously measured, it is recommended to compare this to what is observed by the profiling instrument to evaluate the need for observing a new profile.

- Note that in some cases the coverage capability of the echo sounder cannot be fully utilized, because remaining errors in roll and sound speed profile measurements, which are critical for maintaining the accuracy of the outer beams, become too large. The ray bending effect (Snell's law) may also reduce the online coverage since the energy can bend inwards.

How to plan a new job in SIS

- 1 Select the **Planning module** frame.
The Geographical view must also be accessible.
- 2 Expand **Jobs**.
- 3 Press **New job**
- 4 Enter a descriptive name of the job
- 5 Select your preferred coordinate format
- 6 Expand **Objects**
- 7 Select **New line**, **New polygon**, **New line from** or **New object** depending on your plan.
- 8 Select the end points of your object by pointing the mouse in the geographical view, hold the **Ctrl** button while clicking on the **left mouse** button.
- 9 Hold the **Ctrl** button while clicking on **right mouse** button to bring up the **confirm changes** menu.
- 10 Press **Accept** to finish the object
- 11 Press the **New line**, **New polygon**, **New line from** or **New object** again to finish the process.
- 12 Select one of the planned lines or objects by **ctrl + left mouse** button.
- 13 Observe that the buttons that can be used to modify your plan becomes active.
- 14 Edit, move, extend, reverse, make parallel lines, etc. according to your plan.
- 15 Press **Save Job** or **Save Job as...**
- 16 Transfer plan to the Remote Helmsman display when your plan is ready by expanding **Remote** and pressing **Transfer plan**

Parameter references

- *Planning – Jobs* on page 251
- *Planning – Remote* on page 251
- *Planning – Object* on page 251

Related topics

- *Planning module window* on page 93
- *Keyboard and mouse in the Planning module view* on page 44

Run the survey

Operational procedures

- *How to retrieve a planned job* on page 202
- *How to monitor the survey progress* on page 202
- *How to run the PU simulator* on page 203

How to retrieve a planned job

- 1 Open the **Planning module** frame.
- 2 Expand **Jobs**
- 3 Press the **Open job** button.
A standard file open window appears.
- 4 Select the file where your planned survey lines are stored.
- 5 Verify that the correct job is loaded.
- 6 Expand **Remote**.
- 7 Press **Transfer plan** so send the planned lines and objects to the remote helmsman display.

Related operational procedures

- *Plan a survey* on page 199

Start and stop logging

Observe the procedures in *Start and stop logging* on page 169.

How to monitor the survey progress

There are different ways to monitor the progress depending on the system you are running. The logging and system status is observed and presented in **Status information**. The following is a summary of the **Status information**:

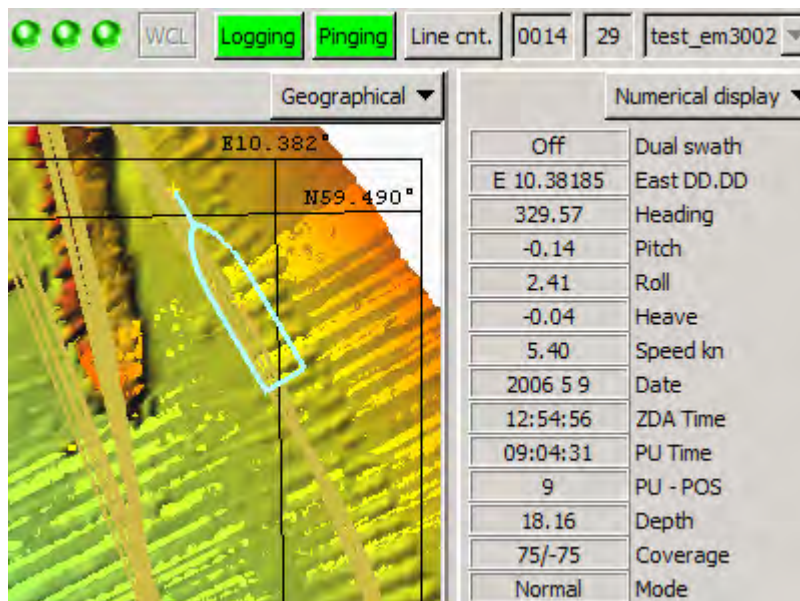

1 Observe the Geographical window.

The **Geographical view** gives an overall control of the performance of SIS and the multibeam echo sounder

2 Observe logging, pinging and line number status.

On the right hand side of the toolbar there are three buttons which show the status of **logging, pinging** and **line number**.

3 Observe the Numerical display

In the **numerical display** view you may select the sensor data values you want to monitor.

4 Observe the status lamps.

Three **status lamps** on the main toolbar give status of hardware units (applies to multibeam echo sounders only).

5 Observe the sound velocity.

How to run the PU simulator

The PU Simulator is a replay program using logged raw data from EM multibeam echo sounders.

1 Start the PU simulator from the Tools→Custom...→PU Simulator menu.

PU.exe will start in the background.

If PU simulator has been run before on your SIS installation you will be prompted whether to continue from last set of raw data or to start a new replay.

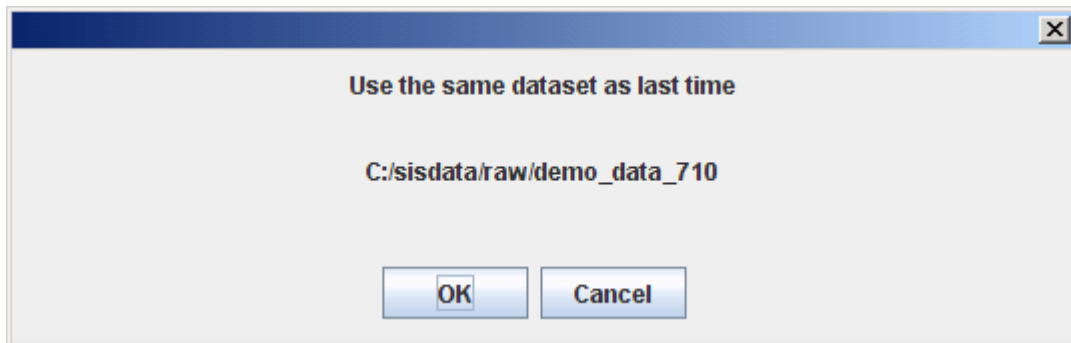

- 2 Press **OK** to continue last dataset.
The **PU control** will open and start output of selected raw data.
or
- 3 Press **Cancel** to select a different dataset.
The **PU control** will open.
- 4 Select the raw data files to replay by pressing **Start**.
A file selection dialog box will open.

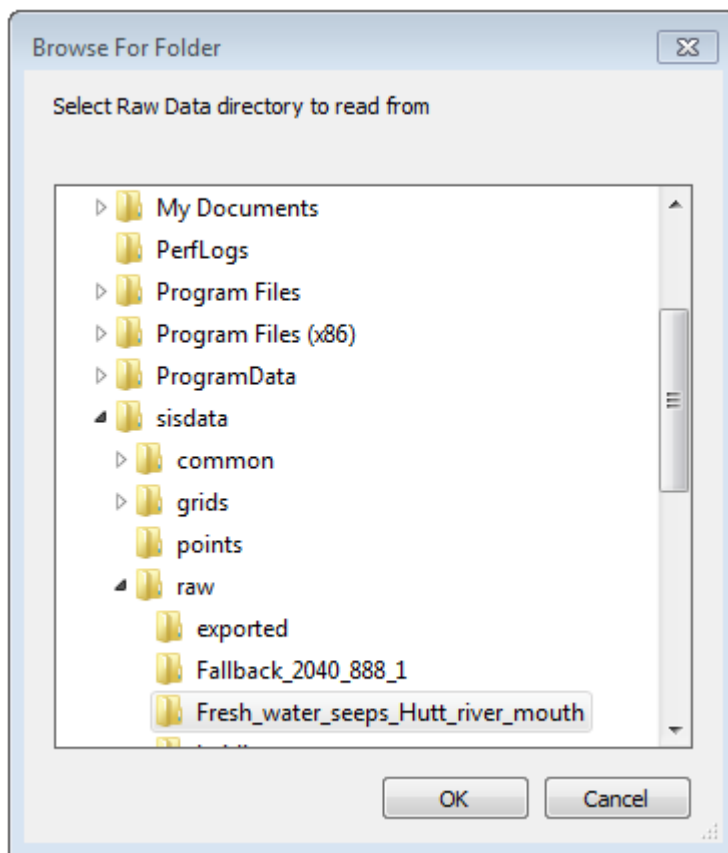

- 5 Browse to the directory of your raw data files.
- 6 Press **Open** to activate the replay.

- 7 Observe that raw data from selected type of echo sounder with head serial number 888 is broadcast in the `PU.exe` command window.

```

C:\Program Files (x86)\Kongsberg Maritime\SIS\bin\PU.exe
BCAST <GMT>:2013/7/18 12:48:50 Head SW: 1.05 101214 Model: 2040 Head: 888
BCAST <GMT>:2013/7/18 12:48:51 Head SW: 1.05 101214 Model: 2040 Head: 888
BCAST <GMT>:2013/7/18 12:48:52 Head SW: 1.05 101214 Model: 2040 Head: 888
BCAST <GMT>:2013/7/18 12:48:53 Head SW: 1.05 101214 Model: 2040 Head: 888
BCAST <GMT>:2013/7/18 12:48:54 Head SW: 1.05 101214 Model: 2040 Head: 888
BCAST <GMT>:2013/7/18 12:48:55 Head SW: 1.05 101214 Model: 2040 Head: 888
BCAST <GMT>:2013/7/18 12:48:56 Head SW: 1.05 101214 Model: 2040 Head: 888
BCAST <GMT>:2013/7/18 12:48:57 Head SW: 1.05 101214 Model: 2040 Head: 888
BCAST <GMT>:2013/7/18 12:48:58 Head SW: 1.05 101214 Model: 2040 Head: 888
BCAST <GMT>:2013/7/18 12:48:59 Head SW: 1.05 101214 Model: 2040 Head: 888
BCAST <GMT>:2013/7/18 12:49:00 Head SW: 1.05 101214 Model: 2040 Head: 888
BCAST <GMT>:2013/7/18 12:49:01 Head SW: 1.05 101214 Model: 2040 Head: 888

```

- 8 Return to the SIS to start and run the simulated echo sounder the same way as you start any other echo sounder.
Note that the serial number of a simulated echo sounder is 888 to distinguish it from an actual echo sounder.
- 9 Press **Rescan** to make SIS recognize the simulated echo sounder with serial number 888.
- 10 Select the simulated echo sounder with serial number 888 from the **Not started** drop-down box.
SIS will soon start running as for an online survey. You can operate SIS as with any other echo sounder.
- 11 If you have a slow computer, you can press **Pause** to allow SIS to catch up.
- 12 You can control the speed of the simulator by reducing the playback rate
- 13 Press **Stop** in the **PU control** window to stop the simulator

Related operational procedures

- *How to start the echo sounder* on page 154

Related topics

- *Time series view* on page 72
- *Numerical display* on page 68
- *Message service view* on page 69
- *PU sensor status view* on page 86
- *Sensor layout view* on page 98
- *Main toolbar* on page 33
- *Sound velocity profile view* on page 79
- *PU simulator and playback* on page 449

Export data

Data can be exported into various output data formats. The formats are described in the parameter section of this manual.

To export data use the **Import/Export** dialogue box found in the **File** menu.

Parameter references

- *Import/Export* on page 352

Remote Helmsman Display

How to start the Remote Helmsman Display

The Helmsman Display must be connected to the echo sounder's operator station (normally the HWS). From the HWS Operator Station you can control what surveys to be displayed on the remote Helmsman Display as follows:

- 1 Import the survey to be shown
- 2 Select **Transfer grids** from the **Planning module**.
- 3 Verify that the same grids (terrain models) are displayed on the Remote Helmsman Display.

How to display planned lines on the Remote Helmsman Display

You can display all the currently planned lines on the Remote Helmsman Display:

- 1 Select **Transfer plan** from the **Planning module**

Current active line will always be sent from the HWS Operator Station to the remote Helmsman Display. The Helmsman is presented with guidance information, such as distance from planned line to current position and other information about current line.

The Helmsman may freely set his own colours, shading, scale and area to display. He can choose to see a completely different area than what is currently surveyed. This makes it possible for the Helmsman to do his own quality assessment of the surveyed data and to take action if required.

If the logging stops for whatever reason, the Helmsman Display will no longer update. This allows the Helmsman to follow the progression of the survey.

Related topics

- *Helmsman display view* on page 70
- *Planning module window* on page 93

Installation of the Remote Helmsman Display is described in the SIS Installation Procedure, document number 164891.

Exporting survey results

How to export survey results after a survey

There are several different possibilities and formats available for exporting the results from a survey:

- 1 Raw data as recorded using the binary instrument data format described in the Operator manual – EM series Datagram Formats, published on the webpage www.kongsberg.com under multibeam echo sounders. Examples of compatible software systems are Neptune B and CARIS HIPS.
- 2 Flags – The flag is compatible with Neptune B. Data cleaning (flagging out soundings) performed by SIS, can be inspected and/or modified in Neptune B.
- 3 All soundings in xyz-format. The following variations can be selected:
 - Depth in centimetres
 - Tide corrected depth (cm). (Correction are derived from predicted or real time tide.)
 - Geoid and RTK corrected depth (cm).
 - Seafloor to geoid distance (cm).
 - Seafloor to ellipsoid distance (cm)
- 4 Grid node value from Grid Engine, binary or ASCII format.
- 5 Contour lines in DAF format. The DAF format is compatible with the DKART software for electronic charting.
- 6 Terrain model generated by CUBE.
- 7 Raw data converted to .XTF format. This is an option which includes a converter program.

Parameter references

- *Import/Export* on page 352
- *Export xyz file* on page 361

Exit SIS

How to exit the SIS software

SIS can be exited by one of the two following methods:

- 1 Stop logging and pinging.
- 2 Select **File**→**Quit**,
or
- 3 Press the **Close** button in upper right corner of the SIS window.

How to shut down the HWS

The SIS HWS (Hydrographic Work Station) is first powered down:

- 1 Switch the power *Off*
- 2 Switch off all peripherals

How to shut down the Processor Unit (PU) or the Transceiver Unit

- 1 Open the door on the Processing/Transceiver Unit
- 2 Switch the power *Off*
- 3 Alternatively, use the Remote Power switch

Parameter references

This chapter provides reference information about the dialog boxes, parameters and functions used throughout the Seafloor Information System (SIS). The information is provided in the following order:

- *Frame toolbars parameters* on page 209
- *Calibration parameters* on page 260
- *Survey parameters* on page 263
- *Installation parameters* on page 274
- *Runtime parameters* on page 297
- *SIS parameters – Set parameters* on page 333
- *File menu parameters* on page 352
- *Tools menu parameters* on page 371
- *Projection and datum parameters* on page 384

Frame toolbars parameters

This section contains description of the dialog boxes and parameter settings provided by the **Frame** toolbars in SIS.

Topics

- *Geographical – Display options* on page 211
- *Geographical – Show depth under cursor* on page 222
- *Geographical – Grid shading* on page 222
- *Geographical – 2D or 3D* on page 223
- *Geographical – Inspection mode* on page 223
- *Geographical – Compass button* on page 223
- *Geographical – KSGPL edit mode* on page 223
- *Geographical – Planning edit mode* on page 224
- *Geographical – Calibration edit mode* on page 224
- *Geographical – Follow ship* on page 224

- *Geographical – Load background data* on page 224
- *Geographical – Save background image* on page 224
- *Geographical – C-MAP manipulation mode* on page 225
- *Geographical – Information field* on page 225
- *Beam intensity – Show/hide* on page 227
- *Colour coded depth – Show/hide* on page 227
- *Cross track – Display options* on page 227
- *Seabed image – Show/hide* on page 231
- *Numerical display* on page 232
- *Helmsman display – Show/hide* on page 237
- *Time series – Show/hide* on page 238
- *Time series – Clear plot* on page 241
- *Waterfall – Show/hide* on page 241
- *Water column – Show/hide* on page 243
- *Water column – Logging* on page 247
- *Sound velocity profile – Show/hide* on page 247
- *Scope display – Show/hide* on page 247
- *Stave display – Show/hide* on page 249
- *Planning – Jobs* on page 251
- *Planning – Remote* on page 251
- *Planning – Object* on page 251
- *Sensor layout – Show/hide* on page 258

Display buttons related to colour selection, zooming and scaling are not included in the following.

Related topics

- *The application window* on page 25
- *SIS frames* on page 27
- *Toolbars* on page 33
- *View menu* on page 38
- *Keyboard and mouse operations* on page 43
- *Common display buttons* on page 48

Related operational procedures

- *How to monitor the external sensors in SIS* on page 160
- *How to monitor the survey progress* on page 202
- *How to display realtime depths* on page 161
- *How to verify echo sounder main functions* on page 162
- *How to display a smooth surface* on page 165

- *How to look for artifacts* on page 165
- *How to display seabed imagery data in the Geographical view* on page 162
- *How to display sound velocity at transducer depth in the Geographical view* on page 163
- *How to create and use a GeoTIFF background image in the Geographical view* on page 166

Geographical – Display options

Options

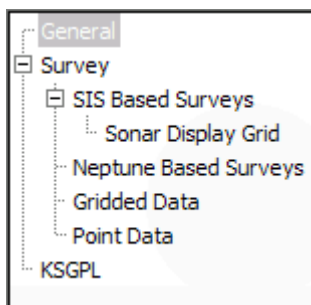

The **Options** menu contains a tree structure on the left side that can be used to select which menu pane (i.e. set of options) to show on the right.

The tree list on the left side contains the following parameter settings:

- General

See *General display options* on page 212.

- Survey

See *Survey display options* on page 214.

- SIS Based Surveys

See *SIS based survey display options* on page 216.

- Sonar Display Grid

See *Sonar display grid options* on page 218

- Neptune Based Surveys

See *Neptune based surveys display options* on page 219.

- Gridded Data

See *Gridded data display options* on page 220.

- Point Data

See *Point data display options* on page 221.

- KSGPL

See *KSGPL display options* on page 222.

Different dialog boxes appear as you click on any of the options. These are described in the following.

General display options

General: Select general display options for the **Geographical** window.

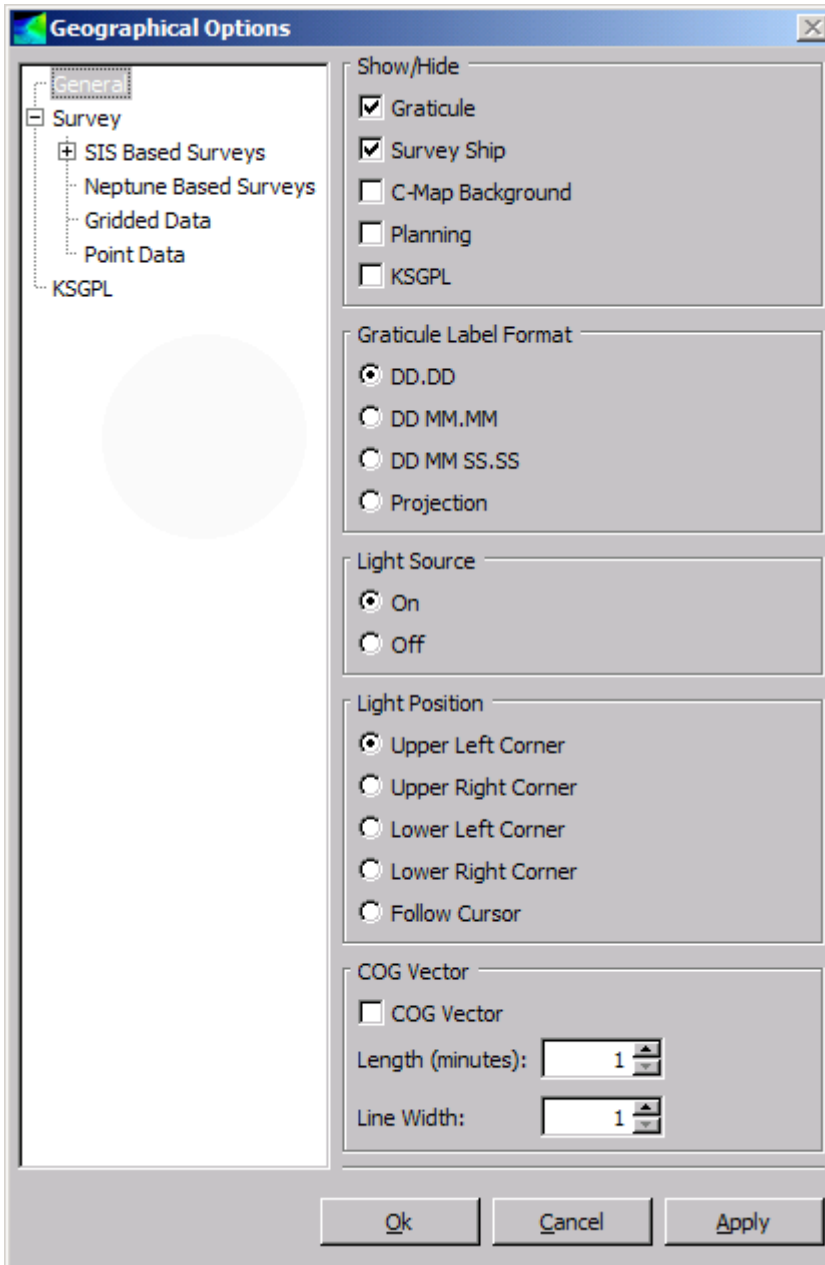

- **Show/Hide:**
 - **Graticule:** Toggle show/hide graticule
 - **Survey ship:** Show the survey ship or not.
 - **C-MAP background:** Use C-MAP as background map. When the C-Map edit is enabled, clicking the right mouse button in the geographical view will display additional C-Map objects information. This option will only be available for C-Map users.

- **Planning:** This will enable the planning module in the **Geographical** window. A planning button **P** will be added to the **Geographical** window toolbar.
- **KSGPL:** Turn KSGPL (Kongsberg SIS Graphic Programming Language) on or off.
 - * Unchecked: No input/output is allowed. This will also hide all the loaded KSGPL objects.
 - * Checked: Use predefined settings.
- **Gaticule Label Format:** Show or hide the position text fields (latitude and longitude)
 - DD.DD: Display position as decimal degrees.
 - DD MM.MM: Display position as degrees and decimal minutes.
 - DD MM SS.SS: Display position as degrees, minutes, and decimal seconds.
 - Projection: Display position as projection coordinates.
- **Light Source:** Toggle light source on or off to achieve shadowed effects
- **Light Position:** Position light source according to your preferences:
 - Upper left corner
 - Upper right corner
 - Lower left corner
 - Lower right corner
 - Follow cursor
- **COG Vector:** When the COG Vector check box is checked, a course over ground (COG) vector is displayed on the ship symbol in the geographical view.
 - The **Length** text box can be used to set the length of the COG vector in minutes (of time). For example, if you set the 'Length' text box to 5, the end of the COG vector should be at the location where the ship will be in 5 minutes (if the ship continues on it's current course).
 - The **Line Width** text box is the width of the COG vector (on the display) in pixels.

Survey display options

Set your preferences for display of current survey.

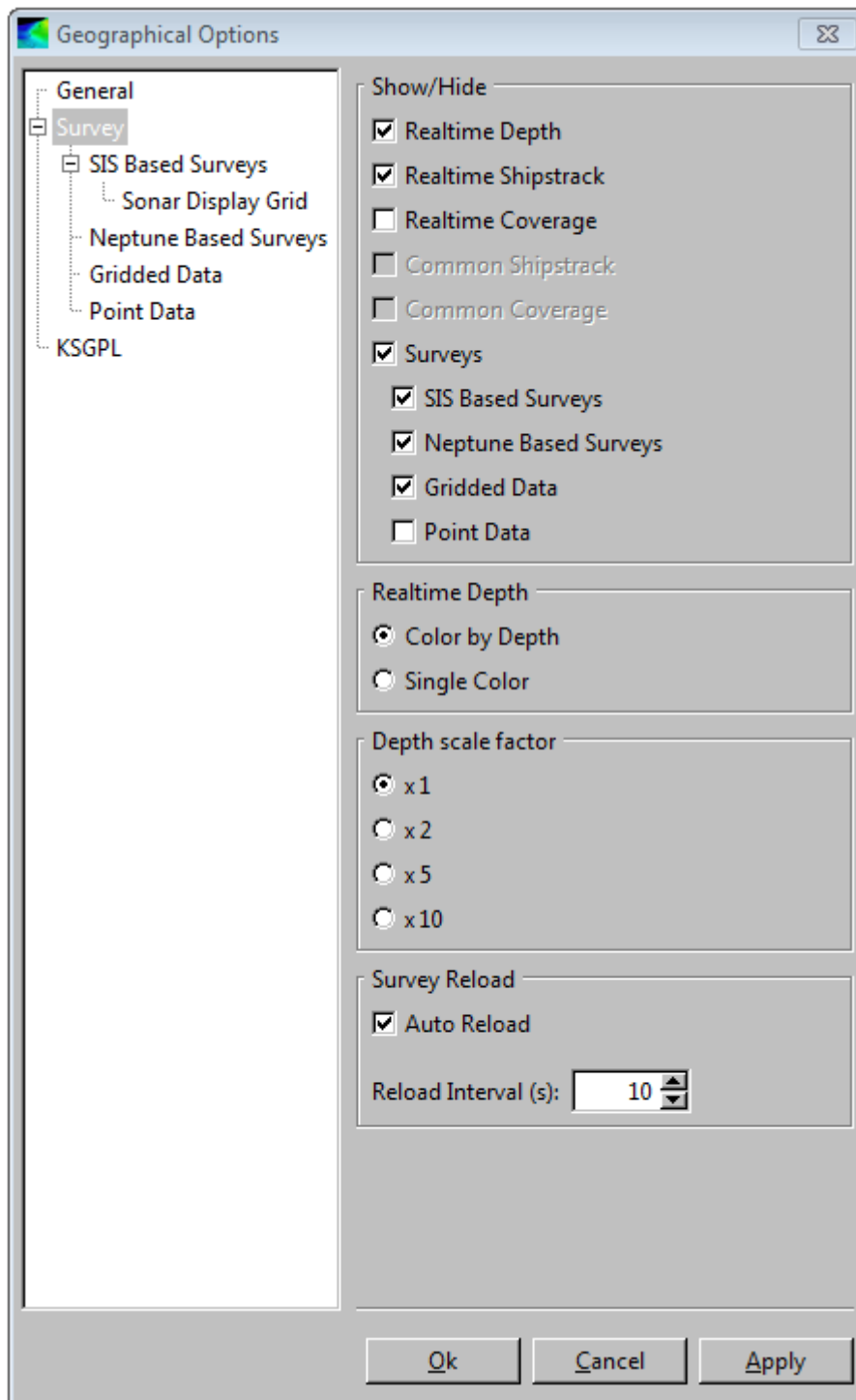

- **Show/Hide:**
 - **Realtime depths:** Show realtime depths or not. All depths can be shown as a tail behind the ship.

- **Realtime shiptrack:** Show shiptrack current line or not.
- **Realtime coverage:** Show coverage from current line or not.
- **Common Shiptrack:** Show shiptrack lines from previous surveys or not.
The common shiptrack data must be stored in a folder named `tracks`. The `tracks` folder must be a subfolder of the “Background data directory” defined for the active survey.
- **Common Coverage:** Show coverage from previous surveys or not.
The common coverage data must be stored in a folder named `tracks`. The `tracks` folder must be a subfolder of the “Background data directory” defined for the active survey.
- **Surveys:** Set what type of surveys you want to be displayed from
 - * SIS Based Surveys
 - * Neptune Based Surveys
 - * Gridded Data
 - * Point Data
- **Realtime Depth:**
 - **Colour by Depth:** Display dynamic colours by depth
 - **Single Colour:** Display one only one colour for all depths
- **Depth Scale Factor:** Factor by which depth is multiplied by. This has the effect of stretching the grid along the depth axis (i.e. a depth scaling factor of 2 stretches the waterfall grid to twice its normal height). This can make it easier for example to discover artefacts.
 - x 1: No scaling
 - x 2: Scale the depth by 2
 - x 5: Scale the depth by 5
 - x 10: Scale the depth by 10
- **Survey Reload:** Interval in seconds between reloading the survey.
May be set to **Auto Reload** by ticking off the check box.

SIS based survey display options

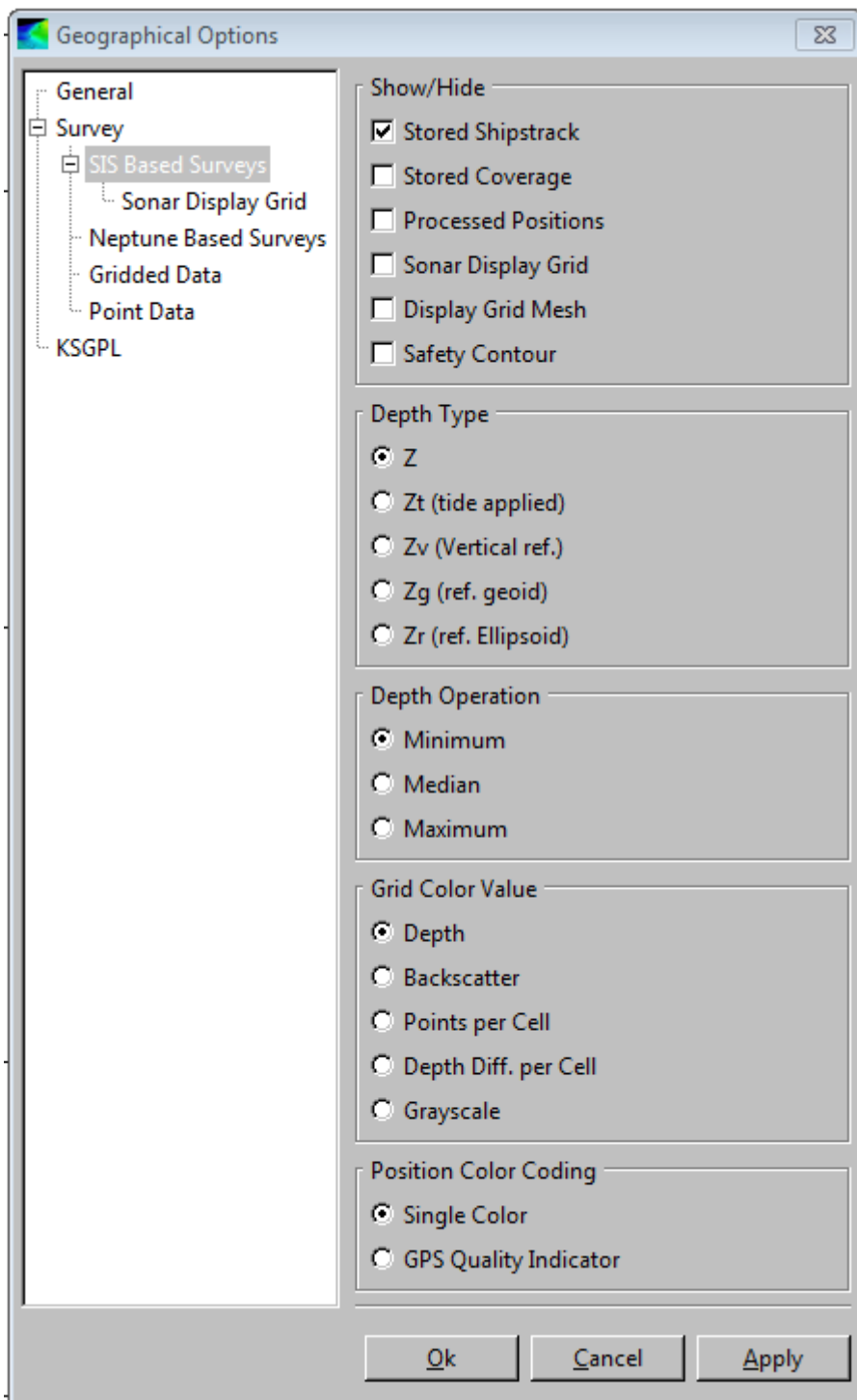

- **Show/Hide:**

- **Stored Shiptrack:** Toggle to show the stored shiptrack or not. Currently logged line/realtime shiptrack will be stored to disk as a stored shiptrack whenever a new line is being created.
- **Stored Coverage:** Show the stored coverage or not. The currently logged line/realtime coverage will be stored to disk whenever a new line is being created.
- **Processed Positions:** Shows position quality. The positions can be colour-coded by the quality indicator in the GGA datagram. Note that logging must be off for position quality to be displayed. IFF is extracted from activated survey. See also *Extract IFF* on page 381.
- **Sonar Display Grid:** Enable or disable the seabed image display in the Geographical window.

Note _____

Must be selected to enable seabed image features described in Sonar display grid options on page 218.

- **Display Grid Mesh:** Toggle to show the display grid mesh or not.
- **Safety Contour:** Toggle to show the safety contour or not.

This feature defines a range of depths below which it is considered too shallow for the survey vessel when accounting for the current tide. This range of depths can be shown in any single colour. Before being able to use the safety contour feature it must be enabled and the required range of depths must be set. This is performed in the **Tools** → **Custom...** → **Set Parameters** → **Display** menu.

- **Depth Type:** Select depth variable to be displayed.

- Z: Depth, sea surface to sea bottom distance.
- Zt: Tide file corrected depth, vertical datum to seafloor distance.
- Zv: Geoid and RTK corrected depth, vertical datum to seafloor distance.
- Zg: Seafloor to geoid distance.
- Zr: Seafloor to ellipsoid distance.

- **Depth Operation:** Parameter to set what depth to be displayed:

- Minimum depth of each cell will be displayed
- Median depth of each cell will be displayed
- Maximum depth of each cell will be displayed

- **Grid Colour Value:** Grid values are presented according to given values with given colour scheme.
 - **Depth:** Display depth values of the grid
 - **Backscatter:** Display backscatter values of the grid
 - **Points per cell:** Display number of cells of the grid
 - **Depth diff. per cell:** Display depth differences in the grid
 - **Grayscale:** Map a grayscale range (i.e. black to white) to a range of data. The grayscale range and the data range to which the grayscale is mapped are set via the **Dynamic Colours** dialogue.
- **Position Colour Coding:** For position monitoring the colour coding of position may be given by
 - Single colour, or by
 - GPS quality indicator

Sonar display grid options

The seabed image data generated by the grid engine can be viewed in the Geographical display.

Note

To show the seabed image data in the Geographical view the following must be enabled:

- *The **Sonar display grid** check box located in the **Show/Hide** menu of the **SIS Based Survey** branch of the **Geographical Options** must be selected.*
- ***Seabed Image Processing in GridEngine** located in **Runtime parameters**→**Data Cleaning**→**Advanced***

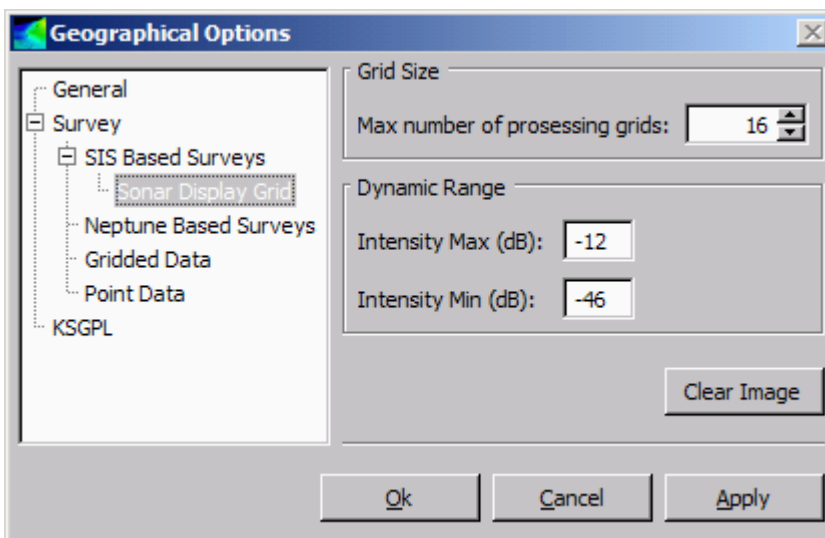

- **Grid size:** Selects maximum number of processing grids to display in the **Sonar Display Grid** option.

Note

The actual size of each processing grid is part of the Grid Engine parameters, and is set from the New Survey tab, through import of raw data or via the Survey Template Handling.

- The **Clear Image** button will clear the geographical display of the seabed image.
- **Dynamic range:** Sets the minimum and maximum intensity values (dB) for the range to be displayed

Please also refer to the operational procedure *How to display seabed imagery data in the Geographical view* on page 162.

Neptune based surveys display options

This choice is available only if you have imported Neptune based surveys.

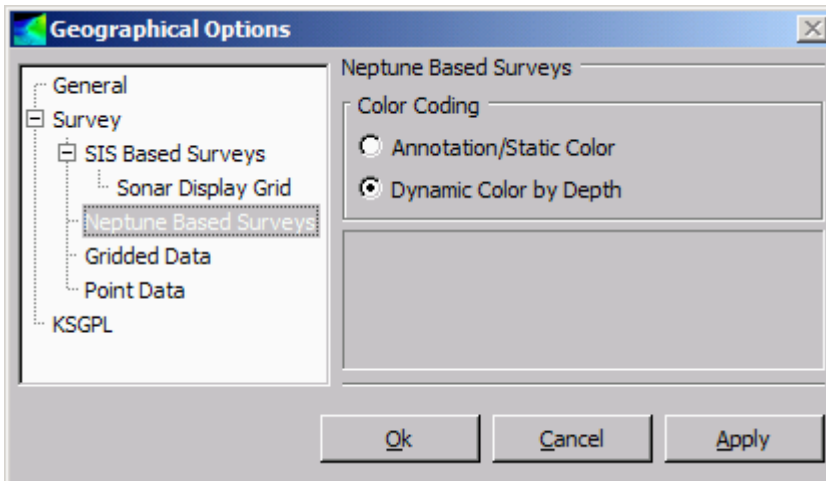

Colour Coding: Check box for selecting whether static or dynamic colour scheme are going to be used for the presentation in the Geographical display.

Gridded data display options

Parameters for presentation of the gridded data in the Geographical display.

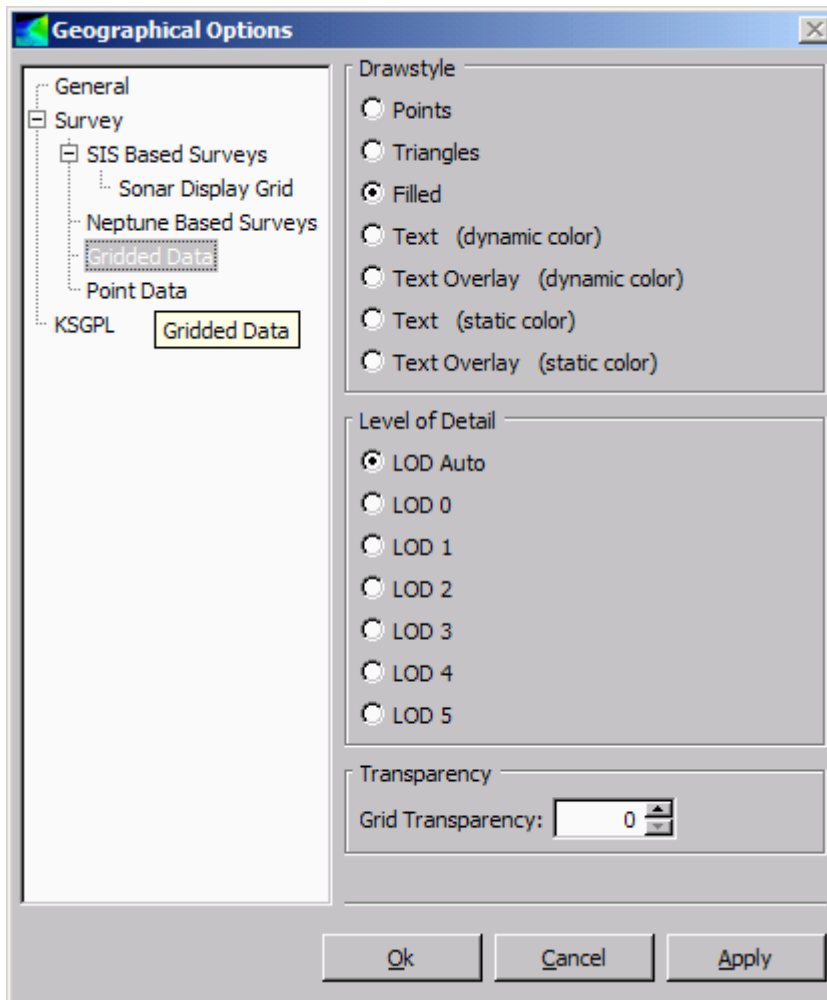

- **Drawstyle:**
 - **Points:** Presents gridded data as points
 - **Triangles:** Presents the triangles used to form the surface formed by the gridded points
 - **Filled:** Presents the filled triangles
 - **Text (dynamic colour):** Presents gridded values as colour coded text
 - **Text overlay (dynamic colours):** Presents the gridded values as colour coded text on top of the filled colour coded surface
 - **Text (static colour):** Presents gridded values as text
 - **Text overlay (static colour):** Presents gridded values as text on top of the filled surface

- **Level of Detail:** Specifies to what level of details the gridded data are to be presented by in the Geographical display
 - **LOD Auto:** SIS will automatically choose the best LOD using available system resources
 - **LOD 0:** Presents all processed data
 - **LOD 1:** Reduced presentation to 1/4 of LOD 0
 - **LOD 2:** Reduced presentation to 1/4 of LOD 1
 - **LOD 3:** Reduced presentation to 1/4 of LOD 2
 - **LOD 4:** Reduced presentation to 1/4 of LOD 3
 - **LOD 5:** Reduced presentation to 1/4 of LOD 4

Refer to *Geographical – Level of Detail* on page 225 for further details
- **Transparency:** Set grid transparency. Choose values from 0 (not transparent) to 100 (maximum transparent)

Point data display options

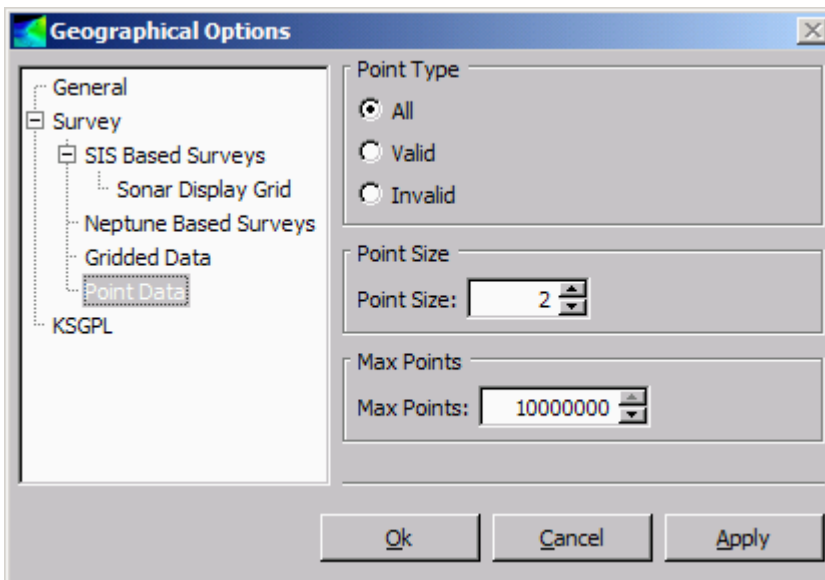

- **Point Type:** Defines what type of points to be displayed of:
 - All points
 - Valid points only
 - Invalid points only
- **Point size** in number of pixels
- **Max points:** Maximum number of points allowed. If there are more points in the area than this no points will be displayed.

KSGPL display options

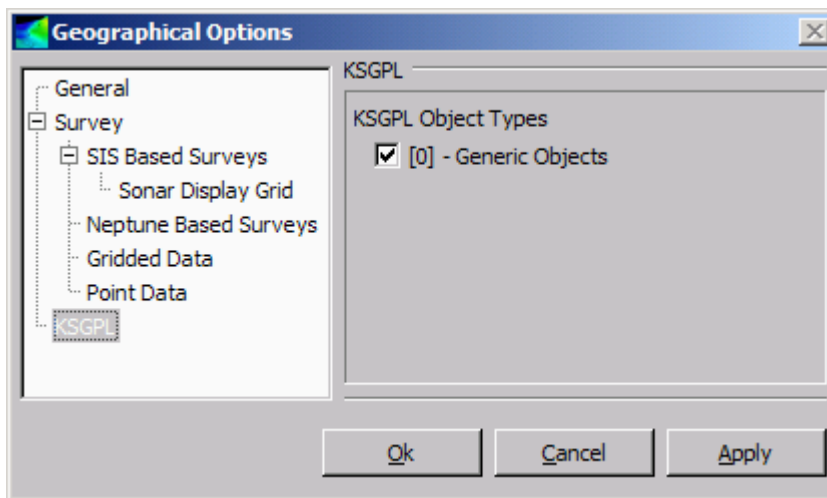

KSGPL Object types:

- [0] – Generic objects (objects without an object type)
- [1] – Coast
- [2] – Dryfall
- [3] – Riverbank
- [4] – Text

Geographical – Show depth under cursor



The depth of the grid under the cursor can be displayed in a pop-up text box by toggling the **Show depth under cursor** button **D**, or by toggling the **F8** hotkey.

Depth under cursor information can be displayed together with position under cursor. Enable the **Compass** button to show position under cursor.

Note _____

The depth will only be displayed as you stop the movement of the cursor.

Geographical – Grid shading



Grid shading can be toggled on/off via the **Toggle Grid Shading** button **S**. The **F4** hotkey can also be used to toggle the grid shading on/off.

Geographical – 2D or 3D



Press the **3D** button to enter the 3D mode. 3D mode will allow you to pan, zoom and rotate the currently loaded grid(s) in 3 dimensions. Panning and zooming will work both in 2D and 3D. **Shift + Right mouse** button will rotate the data. Note that no new data will be reloaded in 3D mode. Press the **3D** button to return to 2D mode.

Geographical – Inspection mode



Inspection mode is used to scan for objects on the seafloor and to filter out noise that may look like objects. The **I** button is used to toggle **inspection mode** on and off. When in inspection mode, the LOD is set to 0, depth operation is set to median depth and the depth scale factor is set to 2. Toggling the **I** button a second time will restore the previous settings.

Geographical – Compass button



The **compass** button is used to read position, distance and heading information from the **Geographical** window.

When enabled the latitude and longitude under the cursor will be displayed. Note that this button can be enabled at the same time as **Depth under cursor** to display both position and depth.

Use **Ctrl + Right mouse** button inside the Geographical window to open the **Compass action** short-cut menu. The following options are available:

- **Measure position:** This is used to display the position of a given point in the view. Move the cursor inside the view. Position information (lat/lon) is given at the cursor's tip.
- **Measure distance and heading:** This is used to measure position, distance and heading between two points in the view. Use **Ctrl + Left mouse** button to mark position 1. Draw a line to position 2 and use **Ctrl + Left mouse** button to mark this position. The requested information is given at the cursor's tip.

Geographical – KSGPL edit mode



Press the **KSGPL** button **K** to allow KSGPL manipulation. This button is made available only if the KSGPL option is selected in the **Options**→**Show/Hide** dialogue box.

Geographical – Planning edit mode



Press this button to allow **Planning** manipulation. This button is made available only if the Planning option is selected in the **Show/hide** dialogue box.

Geographical – Calibration edit mode



Press the **Calibration** button **C** to allow calibration manipulation. This button is made available only if the Calibration window is opened in one of the other frames.

Geographical – Follow ship



This button is used to force current view to follow the ship wherever it moves. It is possible to pan the ship to a user defined location on the screen.

Geographical – Load background data



Press the **Load background data** button to add background data to the **Geographical** window. Data can be loaded from the current active survey or you can browse for stored background files (*.bgksgpl).

Geographical – Save background image

You can create a GeoTIFF image from gridded survey data. You can later import the GeoTIFF file into SIS and display it as background in the Geographical display.

Note

GeoTIFF is a standard which allows georeferencing information to be embedded within a TIFF file.



Pressing the **Save background image** button will save currently displayed survey data to three different files in the background directory `\sisdata\common\background`:

- `gvosr.tif` – a geotiff file
- `gvosr_tmp.tif` – a normal tiff file (not geo-referenced)
- `gvosr_temp.tfw` – a tiff world file (geo-reference information for the tiff file)

Related operational procedures

- *How to create and use a GeoTIFF background image in the Geographical view on page 166*

Geographical – C-MAP manipulation mode

Note

This button is only shown if C-Map is installed.



Press the **C-Map** button to allow C-Map manipulation. This button is made available only if the C-Map background is enabled in the **Options**→**Show/Hide** menu. Please note that C-Map functionality requires a separate C-Map license.

Related topics

- *C-MAP detail level on page 41*
- *C-MAP – Licence administration on page 379*
- *C-MAP CM-93/3 on page 443*

Geographical – Information field

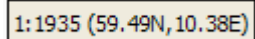

The **Information field** shows current scale of the Geographical window and its position in degrees lat/lon with two decimals. The monitor size is read from the database.

Geographical – Level of Detail

Data may be displayed in the **Geographical window** with various levels of details, based on the current map scale selected by the operator.

The gridding system use two types of grids:

- Processing grid
- Display grid

The processing grid is used for processing depth data, and the display grid is used for displaying data. Data is transferred from the processing grid to the display grid, and from the display grid with a lower level of detail to the display grid with a higher level of detail.

The number of levels of details depends of the number of cells in the processing grid. A processing grid with 64x64 cells will have 6 levels of detail, in other words $\log_2(64)$.

The organization of process grids and display grids may look as shown in the figure below.

Figure 19 Organization of process grids and display grids (example)

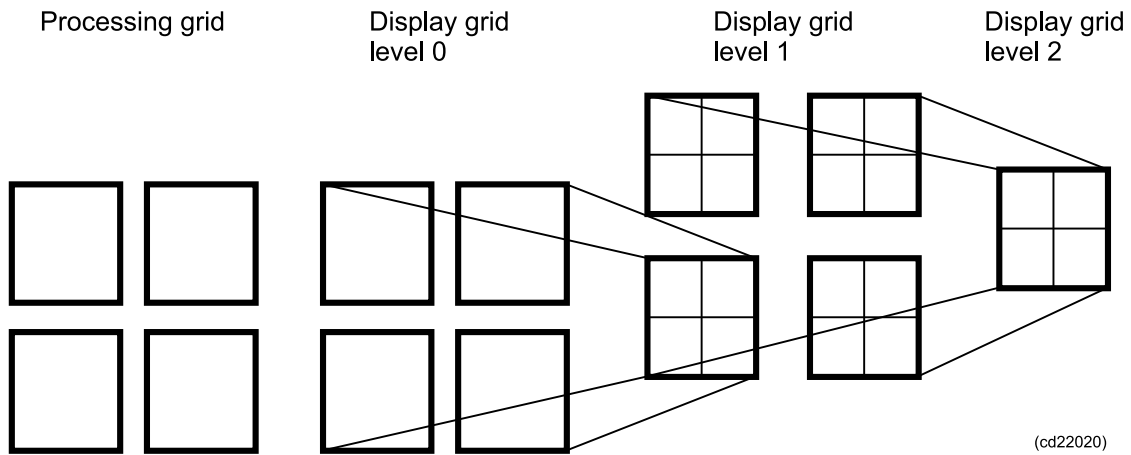

When looking at a small area it can be convenient to select LOD 0, as all processed data then will be displayed. In a larger scale a higher LOD should be used.

Choose between the following levels:

- LOD 0
- LOD 1
- LOD 2
- LOD 3
- LOD 4
- LOD 5
- LOD auto

Note

Due to the limitations in memory and processing capabilities inherent in today's PC platform, it is necessary to impose some restrictions in SIS with regard to display and handling of survey data.

When a high resolution presentation is selected (e.g. LOD 0) more data must be fetched from the GridEngine to be able to display the necessary details.

The restrictions in SIS are imposed when a level of detail other than "LOD auto" is selected. To avoid an overload situation in this case, SIS will restrict the size of the displayed survey area. This will reduce the amount of the fetched data.

When "LOD auto" is set, SIS will automatically choose a LOD level that will not overload the system and no area size restrictions are imposed.

*The settings to control the restriction handling is found in the menu **Tools**→**Custom**→**Set Parameters**→**Advanced display options**. These settings are intended for internal KM use and other advanced users and should normally not be changed.*

Beam intensity – Show/hide

Show/Hide button

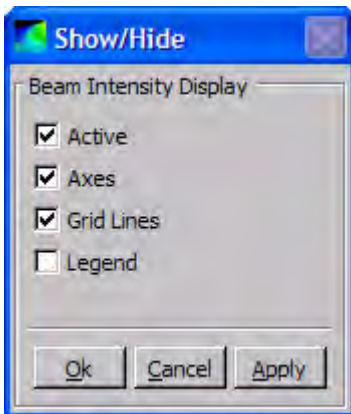

Active: Activate or deactivate the display. Deactivating the display will minimize the CPU usage of the display.

Axes: Show or hide the axes.

Grid Lines: Show or hide the grid lines.

Legend: Show or hide the legend.

Colour coded depth – Show/hide

Show/Hide button

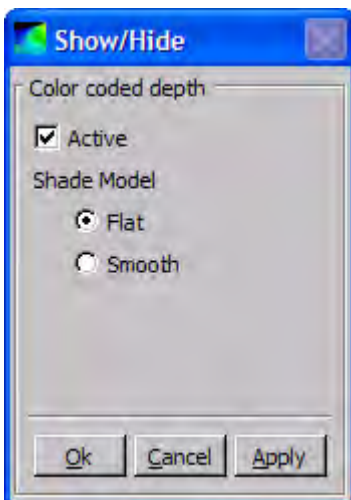

Active: Activate or deactivate the display. Deactivating the display will minimize the CPU usage of the display.

Shade Model: Options for setting the shade model used for displaying the data.

- **Flat:** Each cell has a distinct colour.
- **Smooth:** Colours are smoothly interpolated between cells.

Cross track – Display options

Display options

The **Options** menu contains a tree list on the left side that can be used to select which menu pane (i.e. set of options) will be shown on the right.

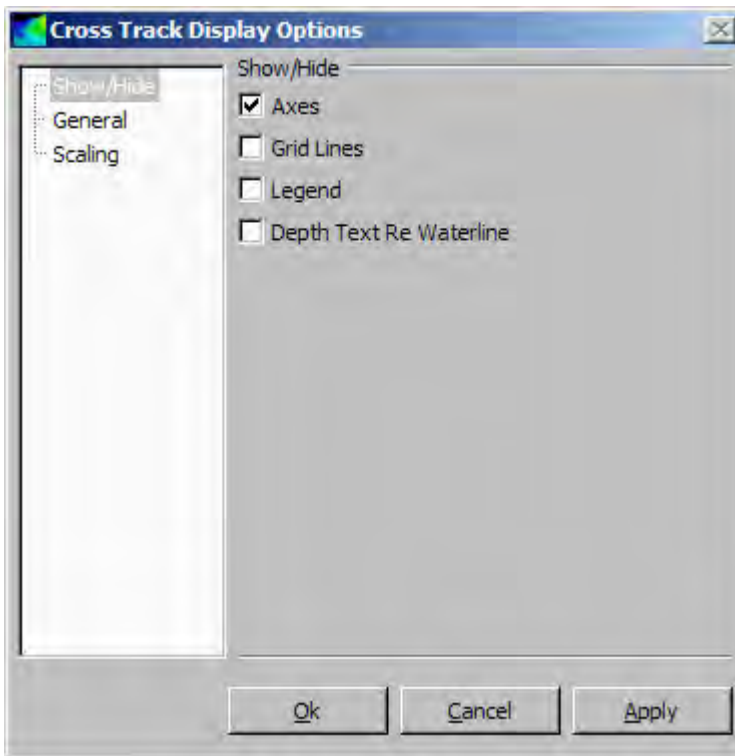

The tree list on the left side contains the following parameter settings:

- Show/Hide
- General
- Scaling

A number of check boxes becomes available for each of above listed cross track display options.

- **Show/Hide:**
 - **Axes:** Show or hide the axes
 - **Grid lines:** Show or hide the grid lines
 - **Legend:** Show or hide the legend

- **Depth Text Re Waterline/Transducer:** When enabled, the depth (selectable reference, either from the waterline or from the transducer) of the most vertical beam will be displayed. The size of depth figure is scaled to fit the frame. Enlarging this window makes it easy to read the depth at distance.

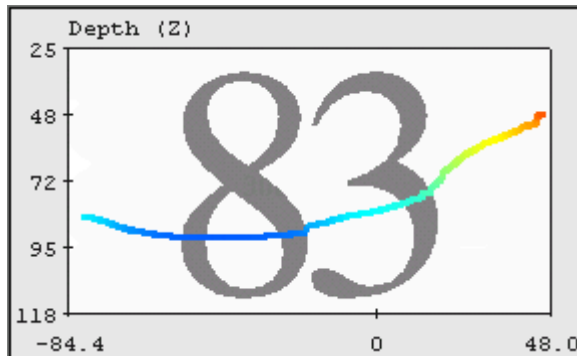

The **Crosstrack depth re** parameter is selected from **Set parameters**→**Display**. If set to 1, the reference is 'waterline'. If set to 2, the reference is 'transducer'. Note that SIS must be restarted for change of this parameter to take effect.

See *Display* on page 339.

- **General:**

- **Refresh Rate:** Specifies the rate with which the display is updated (i.e. number of times per second)
 - * 1: Update the display once every second
 - * 3: Update the display three times per second
 - * 10: Update the display ten times per second
- **Across Track Units:** Select the units for the horizontal axis.
 - * Beams: Units for the across track scale are beams.
 - * Meters: Units for across track scale are meters.
- **Colour Coding:** Select colour coding of the depth curve to be displayed as:
 - * Beam detection: Colours of the depth curve will be red for phase detection and blue for amplitude detection
 - * Depth value: Colours of the depth curve will be displayed according to dynamic colours for depth set by the **Dynamic colour** button of the **Geographical** window. See *Dynamic colours button* on page 50 for description.
- **Depth value:** Select depth variable to be displayed.
 - * Z: Depth, sea surface to sea bottom distance.
 - * Zt: Tide file corrected depth, vertical datum to seafloor distance.
- **Across Track Style:** Select the line style for the across track plot.
 - * Line: The across track plot is displayed as a continuous line.
 - * Points: The across track plot is displayed as a series of points.
- **Point size:** The size of each point in pixels when the style is **Points**. The value specifies line width in pixels when the style is **Line**

- **Deactivate display:** When selected the display become inactive, thus minimize the CPU usage of the display.
- **Scaling:**
 - **Depth:**
 - * **Scaling Mode:** Options for controlling the scaling mode for the depth axis.
 - * **Auto:** Automatically adjust the start and stop ranges to show the entire range of data each time data is received
 - * **Fixed:** Use the start and stop ranges entered in the min and max text boxes:
 - * **Min (m):** **Fixed** start (min) range in meters.
 - * **Max (m):** **Fixed** stop (max) range in meters.
 - * **Scaling factor:** You can choose to scale the cross track vertically by a multiplication factor or by a percentage of the view. This has the effect of stretching or compressing the cross track plot along the depth axis (e.g. a depth scaling factor of 0.25 compresses the cross track plot to a quarter of its normal height). This may be used for e.g. discovering artefacts.
 - * **Compress Depth to Fit View:** When this option is selected, the data will not be stretched outside the current view. In cases where the depth scaling factor would cause the data to be stretched outside the view, this option has the effect of overriding the current depth scaling factor and using the next largest factor that will allow the plot to remain inside the current view. If the current depth scaling factor would not otherwise stretch the data outside the current view, then this setting has no effect.
 - **Across:**
 - * **Scaling Mode:** Options for controlling the scaling mode for the across axis.
 - * **Auto:** Automatically adjust the start and stop ranges to show the entire range of data each time data is received.
 - * **Fixed:** Use the start and stop ranges entered in the min and max text boxes
 - * **Min (m):** **Fixed** start (min) range in meters.
 - * **Max (m):** **Fixed** stop (max) range in meters.
 - * **Keep Across Axis Symmetric:** Keeps the across axis symmetric. If this option is selected, the across axis will be symmetric with respect to zero, even if the coverage is not the same to both sides.

Seabed image – Show/hide

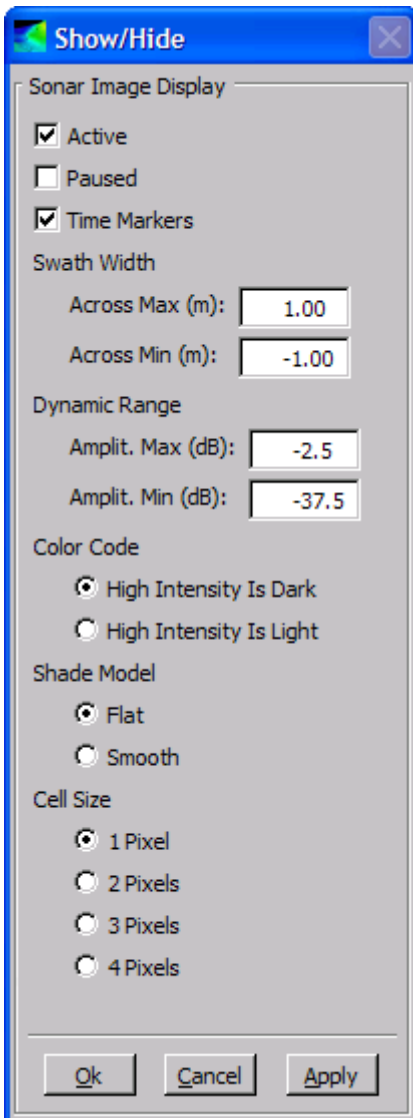

Active: Activate or deactivate the display. Deactivating the display will minimize the CPU usage of the display.

Paused: Pause or continue the display. While paused, the display is shown, but it is not updated with new data.

Time Markers: Show or hide the time markers.

Swath Width: Options for setting the displayed swath width:

- Across Min (m): Across track start (min) range in meters
- Across Max (m): Across track stop (max) range in meters
- Auto scaling is enabled by setting the Swath Width to Across Max (m): 1.0 m and Across Min (m): -1.0 m.

Dynamic Range: Options for setting the amplitude range used for colour mapping.

- Amplit. Min (dB): Minimum expected amplitude
- Amplit. Max (dB): Maximum expected amplitude

Colour Code: Options for setting the type of colour coding used by the display.

- High Intensity is Dark: Darker colour (i.e. more black) indicates higher intensity
- High Intensity is Light: Lighter colour (i.e. more white) indicates higher intensity

Shade Model: Options for setting the shade model used for displaying the data. Smooth shading may provide slightly better results when the cell size is set larger than 1 pixel.

- Flat: Each cell has a distinct colour.
- Smooth: Colours are smoothly interpolated between cells.

Cell Size: Sets the cell size in pixels. Choosing a larger cell size reduces the CPU usage of this display significantly.

- 1 Pixel: Cell size is 1 pixel
- 2 Pixels: Cell size is 2 pixels
- 3 Pixels: Cell size is 3 pixels
- 4 Pixels: Cell size is 4 pixels

Numerical display

The numerical display holds the instantaneous values for the following parameters – in alphabetic order:

Parameter	Description	Note
ATH Log	Shows the status of ATH POSMV data logging, i.e. <i>ON</i> or <i>OFF</i>	8
Across	Across distance between the outermost beams (same as swath width)	
AttVel downward	Attitude Velocity read from the PU Status output datagram. Applies to EM 122, EM302, EM 710, EM 2040 and EM 2040C. For other instruments '—' is displayed.	
AttVel forward	Attitude Velocity read from the PU Status output datagram. Applies to EM 122, EM302, EM 710, EM 2040 and EM 2040C. For other instruments '—' is displayed.	
AttVel starboard	Attitude Velocity read from the PU Status output datagram. Applies to EM 122, EM302, EM 710, EM 2040 and EM 2040C. For other instruments '—' is displayed.	
Beam sp.	Type of footprint/distribution of the beams on the seafloor, for example equidistant or equiangular	
Beams	Beams received versus maximum available beams	
Cover. (deg.)	Coverage in degrees to port and starboard	
Cover. (m)	Across distance in meters of beams on port and starboard side	
DGPS age	Age of differential GPS data in seconds from the NMEA GGA datagram	
Depth	Current centre depth from the waterline to the seafloor. A yellow warning indication is issued when max or min depths are close set limits In case of a warning, the Message Service will also be notified.	1
Depth Sens.	The depth from the depth (pressure) or height datagram or from the Ships Own data (proprietary format) input datagram or from the SIMRAD90 datagram.	
Det. mode	Currently set detector mode. Applies to systems where different detector modes are implemented, i.e. EM 2040, EM 2040C and EM 3002	
Dual swath	Shows status of dual swath settings, Off, Fixed or Dynamic. Applies to EM 122, EM302 and EM 710. Dual swath status is set in the Runtime parameters frame.	
East	Easting in meters in projection coordinates	
East DD.DD	Easting in decimal degrees	
East DDMM.MM	Easting in decimal minutes	
Ext. Date	The date from the clock datagram. The datagram is created by the PU (Processing Unit), but the date information is read from an external input, either ZDA or other GPS input.	
Ext. Time	The time read from the ZDA clock datagram	
Frequency	Transmit frequency in kHz. Applies to EM 2040C.	11
GGA height	Height derived from NMEA GGA datagram	
GGA time	UTC time from NMEA GGA datagram	

Parameter	Description	Note
GSA HDOP	HDOP (Horizontal Dilution Of Precision) from the NMEA GSA datagram	
GST HSTD	HSTD (Horizontal Standard Deviation) derived from the NMEA GST datagram	
Geo. und.	Geoid undulation used (the distance from the ellipsoid to the geoid)	
Geo. vref.	Distance from geoid to vertical reference from geoid model	
HDOP	GPS position HDOP indicator derived from the position input GGA datagram	
Head used	Shows the status of the heads, i.e. <i>ON</i> or <i>OFF</i> , in a dual or three head configuration. Applies to EM 2040, EM 2040C and EM 3002.	
Heading	Heading from the PU status datagram. The heading value is read from the external heading sensor	
Heave	The current heave in meters	3
Height	The height from the depth pressure or height datagram.	
K-Sync	K-Sync synchronization status for up to seven different echo sounder controlled by K-Sync. By holding the cursor on top of one of the coloured status elements the associated echo sounder name will be shown.	10
ME70/BO	Gray colour; connected to Simrad ME70/BO. Red colour; disconnected	
Mode	The current mode used by the echo sounder. Refer to the EM datagram manual	
No. sat.	The number of satellites from the position datagram	
North	Northing in meters in projection coordinates	
North DD.DD	Northing in decimal degrees	
North DDMM.MM	Northing in decimal minutes	
PPS	The 1PPS status from the clock datagram	2
PU-POS	Time difference between PU clock and time in position datagram received in PU.	
PU-ZDA	Time difference between PU clock and ZDA clock received in PU.	
PU date	Time from the PU read from info/status datagram	
PU time	Time from the PU read from info/status datagram	
PU load	PU (Processing Unit) load from the PU status output datagram	
Ping Hz	The ping rate (pings per second)	
Pingno	The current ping number	
Pitch	The current pitch angle in degrees	3
Pos. qual	The position quality calculated from information in the position telegrams. This is an indicator of the relative accuracy of the current position. Refer to the EM datagram manual.	
Qfactor	GPS position quality indicator derived from the position input GGA/GGK datagram	
ROV Offset	Offset (barometer) value sent to echo sounder. Manually entered in Runtime Parameters > Sound Speed frame or received from external barometer sensor. Currently only used for EM 3002	

Seafloor Information System

Parameter	Description	Note
ROV Scale	Scale value sent to echo sounder. Manually entered in Runtime Parameters > Sound Speed frame or automatically calculated. Value is appended with "M" if manually entered. Currently only used for EM 3002	
ROV depth	Depth from water surface to the sonar head/transducer. The depth value contains offset and scaling compensation.	
RTCM Log.	Shows the status of RTCM data logging, i.e. <i>ON</i> or <i>OFF</i>	8
Raw log	Shows status for raw data logging in echo sounder. Status is displayed as ON or OFF. A file name indication in the form of a line number being logged in the echo sounder, is appended when ON. Currently only used for EM 3002	
Ref. st	Name and Id of differential reference station derived from NMEA GGA datagram and file containing reference station names	
Remain. ramp	Remaining time (in seconds) until full effect of the echo sounder is transmitted. Applies to the mammal protection feature of the EM 122, Em 302 and the EM 710.	
Roll	The current roll angle in degrees	3
SRH Log.	Shows the status of SRH data logging, i.e. <i>ON</i> or <i>OFF</i>	8
SV profile	The sound velocity used by the echo sounder	
SV used	The filtered sound velocity from the real time sensor. The filter length is set in the Runtime menu	
SV sensor	Raw unfiltered real time sensor data	
Speed kn	Speed over ground in knots	
Speed m/s	Speed over ground in meters/second	
Swath Dist.	Required swath distance / Achieved swath distance in meters.	
TVG FG	TVG Fixed Gain from the PU status output datagram.	4
TVG NIB	TVG Normal Incidence Backscatter from PU status output datagram.	5
TVG OB	TVG Oblique Backscatter from the PU status output datagram.	6
TVG RN	TVG Range To Normal Incidence from the PU status output datagram.	7
Tx. pow	Transmit power level from the Runtime parameter datagram	
TX pulse (ms)	Pulse length in milliseconds	9
TX pulse form	Currently used pulse type, either CW, FM or a mix of the two. Applies to EM 122, EM 302, EM 710 EM 2040 and EM 2040C. For EM 2040C a time length indication is also included, either short, medium or long.	
Temp probe C	Real time temperature sensor data (in degrees Celsius)	
Tide	Tide used (predicted or real time)	
Yaw. stab	Heading offset angle used by the Transmitter to compensate for ship's yaw. This parameter is also used to show the tilt angle in 3D scanning mode.	

Notes

- 1 When the minimum depth value in a swath (i.e. minimum measured depth) is within a set percentage of the minimum legal depth value set in the **Runtime parameters**→**Sounder Main** window, a yellow warning indication will be given in the **Depth** item in the **Numerical Display** window.

In the same manner, a yellow warning will be given when the maximum depth value in a swath (i.e. maximum measured depth) is within a set percentage of the maximum depth value set in the **Runtime parameters**→**Sounder Main** window.

Also, in both cases a message is sent to the **Message Service** system and logged.

The percentage used is the same for both the minimum and maximum depth settings. The value is set to 10% as standard, but if necessary it can be changed by updating the NUMDISP_PERCENTAGE_MINMAX_DEPTH integer token to the required percentage using e.g. *setParameter.bat* and then restarting SIS.

Legal range for the percentage is 0–100. By setting the percentage to 0 no checks will be performed and no warnings given.

- 2 The 1PPS status is one of the following:

- ON: 1PPS is connected
- OK: Normal operation
- OFF (and red colour): Failure
- UNUSED: No 1PPS is connected

- 3 Monitoring of PU motion sensor input frequency.

The PU must receive motion sensor input with a sufficiently high update rate to be able to produce depth information etc. of an acceptable quality. If the movement of the ship is not properly compensated for when a ping is processed the generated data will be of poor quality or rendered useless.

Numerical display	
N 58.99627	North DD.DD
E 9.99879	East DD.DD
208.98	Heading
1.49	Pitch
0.31	Roll
0.08	Heave
1.94	Speed kn
2009 10 5	Date

SIS will therefore monitor the received motion sensor input rate and generate warning information if it is below a preset frequency. The warning will be in the form of a yellow background in the motion related display items (Roll, Pitch and Heave) in the **Numerical display** frame:

The PU Status Lamp in the Toolbar will also be yellow. In addition a warning will be generated in the message system to the same effect. No pop-up is displayed for this problem.

This frequency monitoring is only performed for the active motion sensor.

The predefined minimum motion sensor input frequency can be changed by using **Tools**→**Custom...**→**Set Parameters** →**Sensor options**

The minimum motion sensor input frequency is set to 90Hz by default.

- 4 **TVG FG (Fixed Gain)**: The older multibeam has two independent gain controls; a fixed gain consistent during each ping, and a time varying gain (TVG), both are controlled by the system software. The newer multibeam, starting with EM 710, has an automatic gain control in the receiver that does not use the fixed gain (FG) parameter. On these systems the TVG applied after the receiver signals have been digitized.

5 The **TVG NIB** (Normal Incidence Backscatter) parameter shows the backscatter level at the normal incidence. The received echo level from the first hit (the normal incidence) depends strongly on the bottom type and the frequency.

6 The **TVG OB** (Oblique Backscatter) parameter shows the oblique backscatter strength. This is an average of the backscatter level measured for the beams placed outside the normal incidence region and inside 60 degrees from the vertical. Time varying gain (TVG) applied to the system shall compensate for the transmission loss, the illuminated area, the bottom incident angle etc.

The model assumes the bottom to be flat, and that the signals is attenuated by spherical spreading (Lamberts law) and absorption loss in the water column.

7 The **TVG RN** Range To Normal Incidence is the estimated shortest range from the transducer to the bottom. The RN is not corrected for the sound speed profile or for the transducer draft, so it may differ some from the actual depth.

8 The **Log** status is updated when a new file is created or as a result of changed log parameter settings. When turning logging on for the first time the "ON" indication will not be displayed until the first data is received from the sensor. A warning (pop-up) is issued if no input is received within a defined interval, currently set to 20 sec.

9 The displayed value is the effective pulse length, which is defined as the inverse of the bandwidth of the transmit pulse.

For CW pulses, this is usually slightly less than the total pulse length (due to shaping of the pulse). For FM pulses, this is equal to the pulse length after pulse compression (match filtering) at the receiver. The effective pulse length usually increases with depth.

For details about actual pulse length in the various modes, see:

- *Sounder main for EM 2040* on page 297

10 The colour shows the K-Sync status according to the following scheme:

- Background: Disabled
- Green: Ready
- Dark green: Trigger and busy after trigger
- Yellow: Busy (explicit Busy status, not as a result of trigger)
- Red: Error

Refer to *K-Sync interface* on page 575 for further details about the K-Sync interface.

11 Dual Head requires different frequencies for the two heads, and there must be a certain frequency separation between the two heads. The operator may choose frequency in 10 kHz steps. The processing unit will select a slightly lower frequency for one head and a slightly higher frequency for the other head. The required separation is a function of used pulse length - the shorter the pulse is, the larger the frequency separation needs to be. The average of the two frequencies will be available in the Numerical Display. For multiple swaths, if the highest or lowest frequencies are selected by the operator, the average frequency (Numerical Display) may show a different number.

Helmsman display – Show/hide

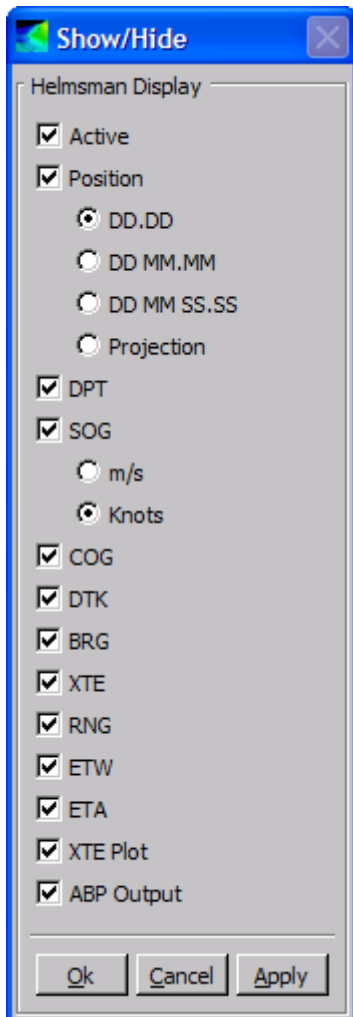

Active: Activate or deactivate the display. Deactivating the display will minimize the CPU usage of the display.

Position: Show or hide the position text fields (latitude and longitude).

- DD.DD: Display position as decimal degrees
- DD MM.MM: Display position as degrees and decimal minutes
- DD MM SS.SS: Display position as degrees, minutes and decimal seconds
- Projection: Display position as projection coordinates

DPT: Show or hide the water depth text field.

SOG: Show or hide the speed over ground text field.

- m/s: Display speed over ground in units of meters per second
- Knots: Display speed over ground in units of knots

COG: Show or hide the course over ground text field. This is the course between position updates.

DTK: Show or hide the desired track text field. This is the heading of the current line segment.

BRG: Show or hide the course to waypoint text field. This is the heading from the current position to the next waypoint.

XTE: Show or hide the cross track error text field. This is the shortest distance to the current line segment.

RNG: Show or hide the range to waypoint text field. This is the distance from the current position to the next waypoint.

ETW: Show or hide the estimated time to the next waypoint text field. This is the estimated time of arrival at the next waypoint.

ETA: Show or hide the estimated time of arrival text field. This is the estimated time of arrival at the last point in current planned line.

XTE Plot: Show or hide the cross track error plot.

APB Output: Enable or disable output of the NMEA APB message to the autopilot.

For the setup of the serial line see *External sensors* on page 371

Caution

NMEA APB datagrams contain information about the vessel's position with relative to the active survey line. The correctness of this information is critically dependent of the positioning system input, correct setup of the system and user definition of the survey. Using the APB datagrams as autopilot input is possible as a help in steering the vessel during the survey, but it cannot in any way relieve the vessel crew from the responsibility in safe handling of the vessel. The APB output is only available when the Helmsman Display window is open.

Time series – Show/hide



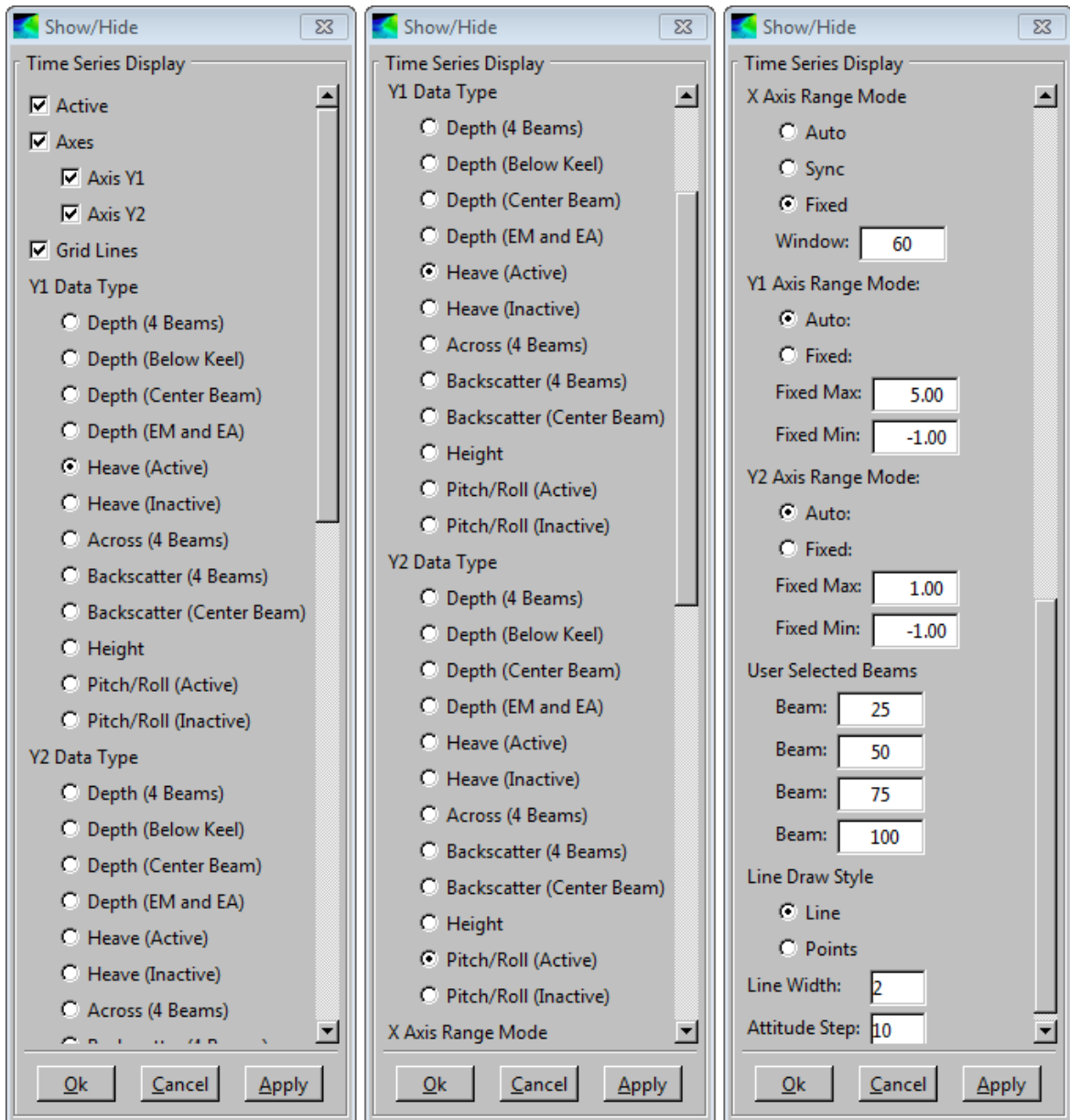

Active: Activate or deactivate the display. Deactivating the display will minimize the CPU usage of the display.

Axes: Show or hide the axes

- Show or hide axis Y1
- Show or hide axis Y2

Grid lines: Show or hide the grid lines.

Y1 Data Type: Select the data type to plot on the Y1 axis from the following variables:

- Depth (4 beams): Depth of four user selected beams
- Depth (below keel): Depth below the water surface for the most vertical beam. The centre beam is most likely not the most vertical beam due to the roll of the vessel.
- Depth (centre beam): Depth of the centre beam
- Depth (EM and EA): Depth of the EA (single beam echo sounder) compared to the depth of the shallowest EM (multibeam echo sounder) beam (in the ping) that lies within the footprint of the EA sounder.
- Heave (active): Heave from the active motion sensor. This is selected for graphical presentation.
- Heave (inactive): Heave from the inactive motion sensor. This is logged to the hard disk.
- Across (4 beams): Across track distance of four user selected beams
- Backscatter (4 beams): Backscatter strength of four user selected beams
- Backscatter (centre beam): Backscatter strength of the centre beam
- Height: Height from the height sensor
- Pitch/Roll (active): Pitch and roll from the active motion sensor. This is selected for graphical presentation
- Pitch/Roll (inactive): Pitch and roll from the inactive motion sensor. This is logged to the hard disk

Y2 Data Type: Select the data type to plot on the Y2 axis.

- Depth (4 beams): Depth of four user selected beams
- Depth (below keel): Depth below the water surface for the most vertical beam. The centre beam is most likely not the most vertical beam due to the roll of the vessel.
- Depth (centre beam): Depth of the centre beam
- Depth (EM and EA): Depth of the EA (single beam echo sounder) compared to the depth of the shallowest EM (multibeam echo sounder) beam (in the ping) that lies within the footprint of the EA sounder.
- Heave (active): Heave from the active motion sensor. This is selected for graphical presentation.
- Heave (inactive): Heave from the inactive motion sensor. This is logged to the hard disk.
- Across (4 beams): Across track distance of four user selected beams
- Across (4 beams): Across track distance of four user selected beams
- Backscatter (4 beams): Backscatter strength of four user selected beams
- Backscatter (centre beam): Backscatter strength of the centre beam
- Height: Height from the height sensor
- Pitch/Roll (active): Pitch and roll from the active motion sensor. This is selected for graphical presentation
- Pitch/Roll (inactive): Pitch and roll from the inactive motion sensor. This is logged to the hard disk

X axis Range Mode: Mode used to set the X axis (time axis) range.

- Auto: Use the range of the longest displayed data series (show all data)
- Sync: Use the longest range common to all the displayed data series
- Fixed: Set the range to a fixed number of seconds
 - Window: Range (time window) in seconds

Y1 axis Range Mode: Mode used to set the Y1 axis range.

- Auto: Use the range of the longest displayed data series (show all data)
- Fixed: Specify a fixed range
 - Fixed Max: maximum (upper) range
 - Fixed Min: minimum (lower) range

Y2 axis Range Mode: Mode used to set the Y2 axis range.

- Fixed Max: maximum (upper) range
- Fixed Min: minimum (lower) range

User Beams: The beams for the data types which require the user to select four beams. This feature is used to compare beams, normally on a flat seabed.

- Beam: First user selected beam
- Beam: Second user selected beam
- Beam: Third user selected beam
- Beam: Fourth user selected beam

Line Draw Style: Select the line style for the across track plot

- Line: The across track plot is displayed as a continuous line.
- Points: The across track plot is displayed as a series of points.

Line width: The line width in pixels when the style is **Line**. The value specifies point size in pixels when the style is **Points**

Attitude Step: Decimal factor for the attitude data

Time series – Clear plot



Press the **Clear plot** button to clear the time series display at any time.

Waterfall – Show/hide



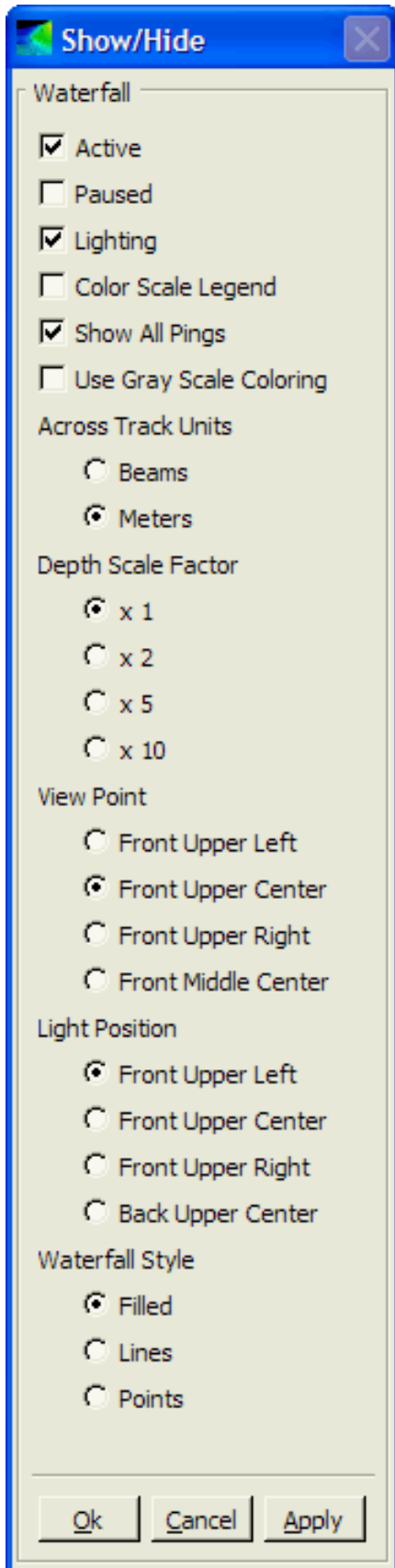

Active: Activate or deactivate the display. Deactivating the display will minimize the CPU usage of the display.

Paused: Pause or continue the display of waterfall data. While paused, the display is visible, but it is not updated with new data.

Lighting: Enable or disable lightning (and 3D shading). Useful in situations where the shape of the grid is such that shading makes the grid (or portions of the grid) difficult to see.

Colour Scale Legend: Show or hide the colour scale legend (shown along the bottom of the grid).

Show All Pings: When selected, all pings are displayed. When not selected, only the most recent ping is displayed. Deselecting this options can reduce the CPU load of this display significantly (depending on the ping rate).

Use Gray Scale Coloring: Display the Waterfall in grayscale. This mode requires less CPU than the full colour mode.

Across Track Units: Select the units for the horizontal axis.

- Beams: Unit for the across track scale is beams
- Meters: Unit for across track scale is meters

Depth Scale Factor: Factor to multiply the depth with. This has the effect of stretching the waterfall grid along the depth axis (e.g. a depth scaling factor of 2 stretches the waterfall grid to twice its normal height). This can e.g. make it easier to discover artefacts.

- x 1: No scaling
- x 2: Scale the depth by 2
- x 5: Scale the depth by 5
- x 10: Scale the depth by 10

View Point: Set the point from where the grid is viewed.

- Front Upper Left: Set the view point to the front upper left of the grid
- Front Upper Centre: Set the view point to front upper centre of the grid
- Front Upper Right: Set the view point to front upper right of the grid

- Front Middle Centre: Set the view point to front middle centre of the grid

Light Position: Set the position of the light source.

- Front Upper Left: Position the light source at front upper left of the grid
- Front Upper Centre: Position the light source at front upper centre of the grid
- Front Upper Right: Position the light source at front upper right of the grid
- Back Upper Centre: Position the light source at back upper centre of the grid

Waterfall Style: Set the style in which the waterfall grid is displayed.

- Filled: The grid is displayed as a surface
- Lines: The grid is displayed as a triangle mesh
- Points: The grid is displayed as a point set

Water column – Show/hide

Show/Hide button



Note

Please note that the Water column show/hide menu has a scroll bar that must be used to see all options.

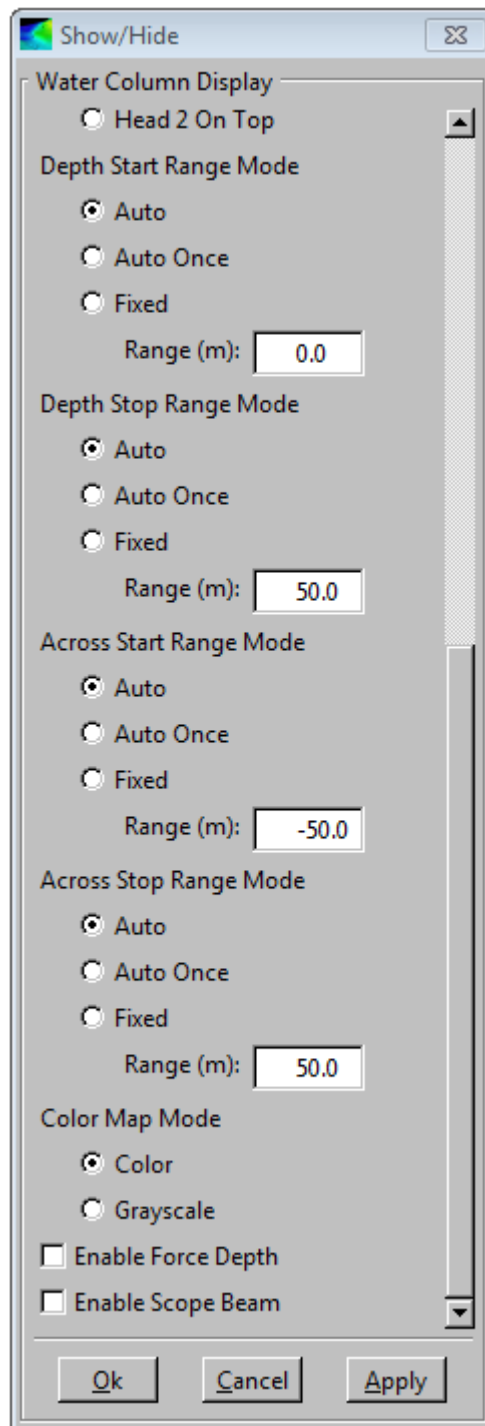
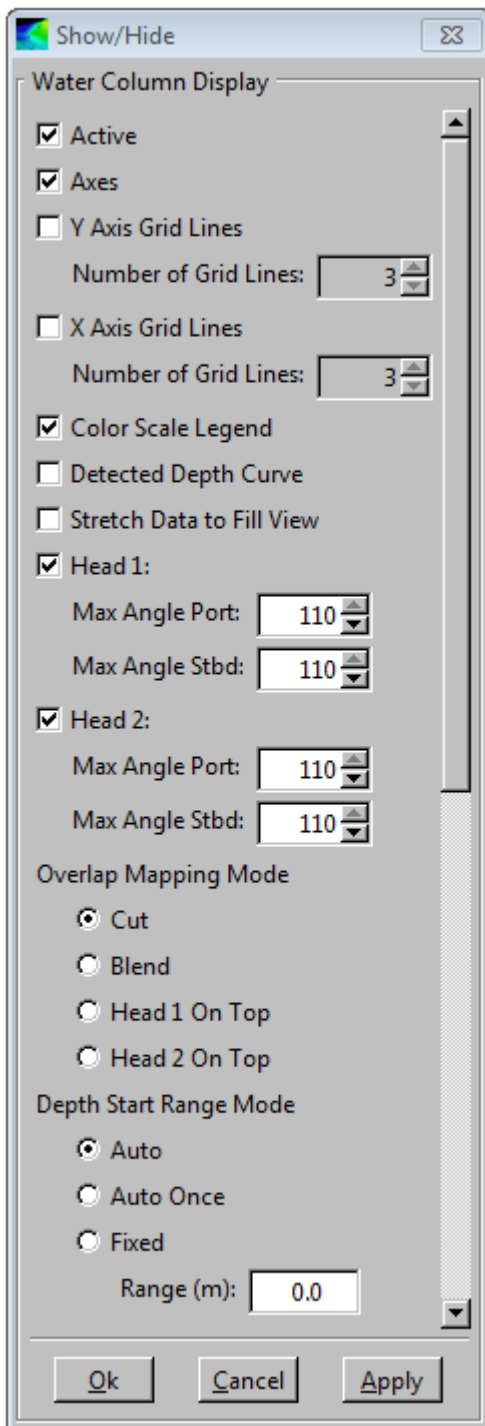

Active: Activate or deactivate the display. Deactivating the display will minimize the CPU usage of the display.

Axes: Show or hide the axes.

Y and X axis grid lines: Show or hide X and Y grid lines, and how many grid lines to show.

Colour Scale Legend: Show or hide the colour scale legend (shown along the bottom of the grid).

Detected Depth Curve: Show or hide a curve showing the detected depth for all beams. The curve is shown on top of the water column data.

Stretch Data to Fill View: When this option is not selected, the same scale is used for both the x- and y-axis. The data is displayed with correct proportions, but this may result in a lot of unused space in the view. When selecting this option, the x- and y-axis are scaled to fill the window.

Head 1: Show or hide the data from sonar head 1.

- Max Angle Port: The maximum beam angle to the port side for sonar head 1
- Max Angle Stbd: The maximum beam angle to the starboard side for sonar head 1

Head 2: Show or hide the data from sonar head 2 (applicable for dual sonar head sounders only).

- Max Angle Port: The maximum beam angle to the port side for sonar head 2
- Max Angle Stbd: The maximum beam angle to the starboard side for sonar head 2

Overlap Mapping Mode: Options for controlling how the data in the overlapped region is displayed (applicable to dual sonar head echo sounders only).

- Cut: The data from each head is cut vertically at 0 meters across
- Blend: The overlap area is blended using alpha blending.
- Head 1 on Top: The data from head 1 is displayed on top of the data from head 2.
- Head 2 on Top: The data from head 2 is displayed on top of the data from head 1.

Note

Blend Overlap Mapping Mode is not enabled if the background colour is any other colour than black. Although it is not possible to change the background colour using Water Column Display menus, the SIS application does provide means to change the background colour via the Colour Dialog menu.

Depth Start Range Mode: Options for controlling the start range mode of the depth axis scale.

- Auto: Automatically set the start range of the depth axis to match the minimum value of the data each time data is received.
- Auto Once: Automatically set the start range of the depth axis to match the minimum value of current data, then lock to this value in fixed range mode.
- Fixed: Use the start range for the depth axis entered in the Range (m) text box
 - Range (m): Fixed start range (in metres)

Depth Stop Range Mode: Options for controlling the stop range mode of the depth axis scale.

- Auto: Automatically set the stop range of the depth axis to match the maximum of the data.
- Auto Once: Automatically set the stop range of the depth axis to match the maximum range of current data, then lock to this value.
- Fixed: Use the stop range entered in the (Stop) Range text box.
 - Range (m): Fixed depth axis stop range (in metres).

Across Start Range Mode: Options for controlling the start range mode of the across axis scale:

- Auto: Automatically set the start range of the across axis to match the minimum value of the data each time data is received.
- Auto Once: Automatically set the start range of the across axis to match the minimum value of current data, then lock to this value in fixed range mode.
- Fixed: Use the range entered in the (Start) Range text box.
 - Range (m): Fixed across axis start range (in metres)

Across Stop Range Mode: Options for controlling the stop range mode of the across axis scale.

- Auto: Automatically set the stop range of the across axis to match the maximum value of the data each time data is received.
- Auto Once: Automatically set the stop range of the across axis to match the maximum range of current data, then lock to this value in fixed range mode.
- Fixed: Use the range entered in the (Stop) Range text box.
 - Range (m): Fixed across axis stop range (in metres).

Colour Map Mode: Select the type of colour mapping to be used by the display.

- Colour: Map a range of colours to a range of data. The range of colours and the data range to which the colours are mapped are set via the **Dynamic Colours** dialogue.
- Grayscale: Map a grayscale range (i.e. black to white) to a range of data. The grayscale range and the data range to which the grayscale is mapped are set via the **Dynamic Colours** dialogue.

Enable Force Depth: When enabled you may use the **Ctrl+left mouse** button to force the bottom detection to a depth selected from the water column display. This has the same effect as setting the **Force depth** parameter in the **Depth settings** field found under **Runtime parameters**→**Sounder main**→**Depth settings**.

Enable Scope Beam: When enabled you may select which beam to display in the **Scope display**. The beam number is selected by pressing the **Shift** button while clicking using **left mouse** button on the selected beam.

Water column – Logging

Water column data can selectively be logged to either the standard log file (.all) or to a separate water column file (.wcd). Water column datagrams can not be logged to both files simultaneously.

Water column logging to separate file must be enabled in the **Output setup** tab under **Installation parameters**.

Logging is toggled on/off from the **Main toolbar**.

Please note that the logged data amount is very large, that is, typically 1 to 2 Gigabytes per hour.

Separate water column data (.wcd) files may optionally be logged to a disk different from the one used for the raw data (.all) files. Water column data file locations are set from the **Logging** option accessed from **Tools**→**Custom**→**Set Parameters** for details.

Sound velocity profile – Show/hide

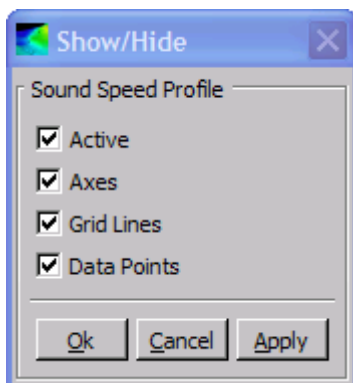

Active: Activate or deactivate the display. Deactivating the display will minimize the CPU usage of the display.

Axes: Show or hide the axes.

Grid Lines: Show or hide the grid lines.

Data Points: Show the sound velocity profile sample values on the sound velocity profile plot.

Scope display – Show/hide



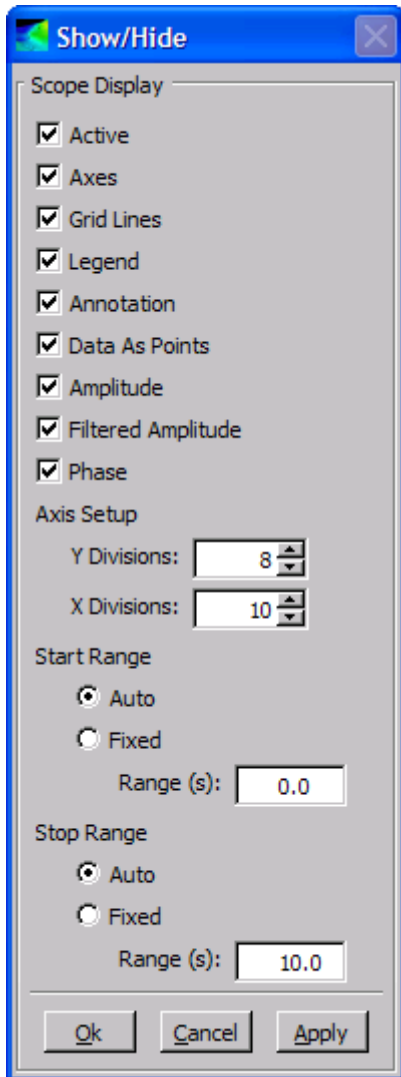

Active: Activate or deactivate the display. Deactivating the display will minimize the CPU usage of the display.

Axes: Show or hide the axes.

Grid Lines: Show or hide the grid lines.

Legend: Show or hide the legend.

Annotation: Show or hide the on screen text annotation.

Data As Point: Show the data series as a series of points, rather than a solid line.

Amplitude: Show or hide the amplitude plot.

Filtered Amplitude: Show or hide the plot of the filtered amplitude.

Phase: Show or hide the plot of the electrical phase difference between the two so-called half beams. This is also called the interferometric, or split beam, phase signal.

Axis Setup: Option for defining number of grid lines along the x and y axes.

- Y Division: Number of divisions along the y-axis
- X Division: Number of divisions along the x-axis

Start Range: Options for controlling the start range mode of the x-axis scale.

- Auto: Automatically set the start range of the x-axis to match the minimum value of the data

each time data is received.

- Fixed: Use the start range for the x-axis entered in the Range (s) text box
 - Range (s): Fixed start range (in seconds)

Stop Range: Options for controlling the stop range mode of the x-axis scale.

- Auto: Automatically set the stop range of the x-axis to match the maximum of the data.
- Fixed: Use the stop range entered in the (Stop) Range text box.
 - Range (s): Fixed stop range (in seconds).

Stave display – Show/hide

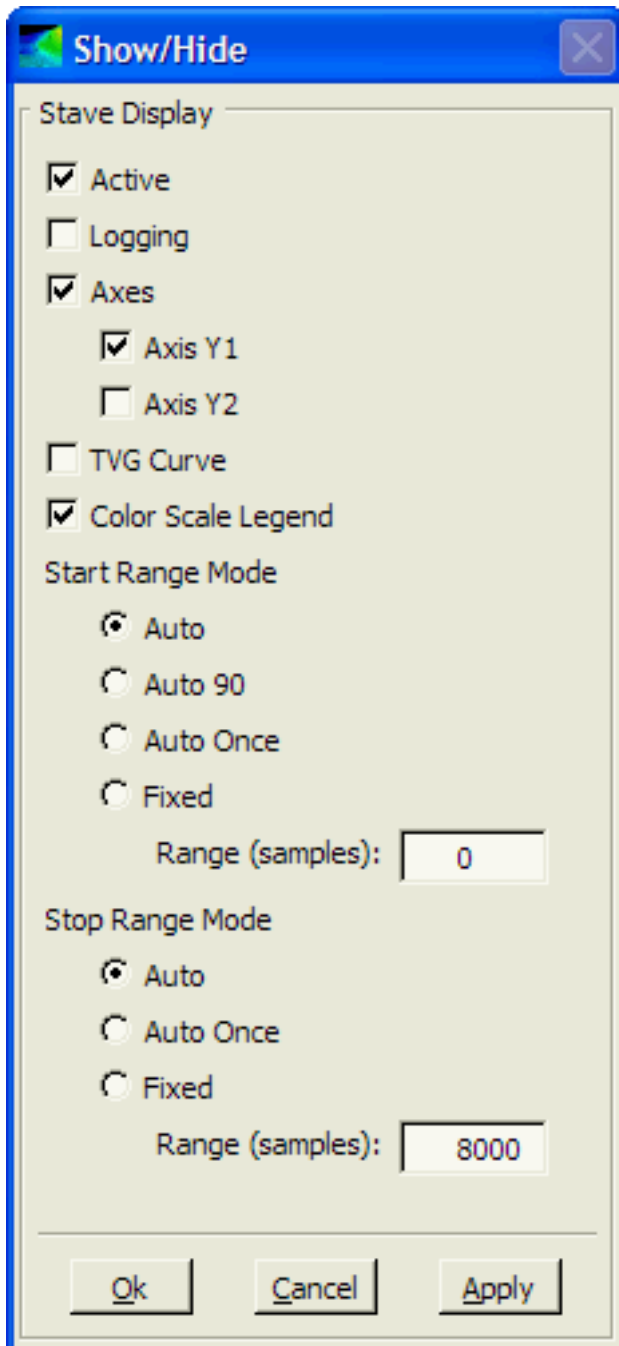

a single ping.

Active: Activate or deactivate the display. Deactivating the display will minimize the CPU usage of the display.

Logging: Enable/disable logging of stave data to the **.all** file.

- The **Stave display** must be open and remain open to log stave data.
- Standard logging must be started/active (i.e. the **Logging** button in the SIS main toolbar must be green).

Axes: Show or hide the axes.

- **Axis Y1:** Show or hide the Sample axis (the vertical axis to the left of the grid).
- **Axis Y2:** Show or hide the Range axis (the vertical axis to the right of the grid).

TVG Curve: Show or hide the TVG (time varying gain) curve. When shown, the TVG curve is displayed on top of the Stave data grid.

Colour Scale Legend: Show or hide the colour scale legend (shown along the bottom of the grid).

Paused: Pause or continue the display of stave data. While paused, the display is visible, but it is not updated with new data. This may be useful for example if you want to look at the cell information of more than one cell in the grid for

Start Range Mode: Options for controlling the start range mode for the vertical scale(s).

- Auto: Automatically set the start range to match the minimum range of the data each time data is received.
- Auto 90: Automatically set the start range to be 90 percent of the range to normal incidence each time data is received.
- Auto Once: Automatically set the start range (once) to match the minimum range of the data, then keep this fixed range.
- Fixed: Use the range entered in the Range (samples) text box.
 - Range (samples): Fixed start range (in samples).

Stop Range Mode: Options for controlling the stop range mode for the vertical scale(s).

- Auto: Automatically set the stop range to match the maximum range of the data each time data is received.
- Auto Once: Automatically set the stop range (once) to match the maximum range of the data, then keep this fixed range.
- Fixed: Use the range entered in the Range (samples) text box.
 - Range (samples): Fixed stop range (in samples).

Planning – Jobs

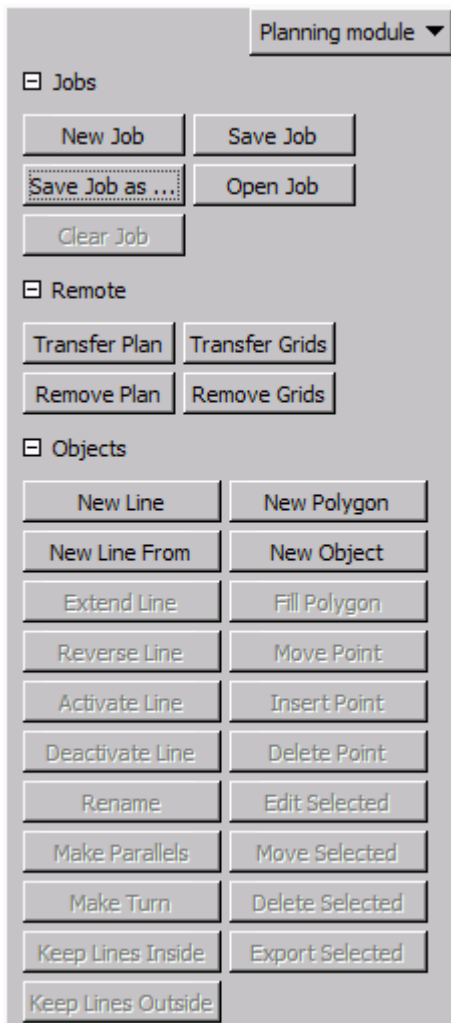

These buttons are used to create and save a new job, or to reactivate an existing job.

A job is a collection of planned lines and possibly one or more polygons. Each job is given a unique name. A job must first be selected as the current job before any other operations can be performed. The selected job can either be new, or you can continue to work on an existing job.

The following options are available:

- **New Job:** Create a new job
- **Open Job:** Open an existing job
- **Save Job:** Save the current job
- **Save Job as...:** Save the current job using a different name
- **Clear Job:** Clear the current job from the graphical display

Planning – Remote

These buttons are used to transfer data to a remote Helmsman Display, see *Remote Helmsman Display* on page 206.

Whenever data is transferred to the remote display it will replace whatever is already there. All defined lines, polygons and grids will automatically be transferred if **Transfer Plan** or

Transfer Grids is selected.

The following options are available:

- **Transfer Plan:** Transfers lines and polygons to the remote display
- **Remove Plan:** Removes lines and polygons from the remote display
- **Transfer Grid:** Transfers the terrain data to the remote display
- **Remove Grid:** Removes the terrain data from the remote display

Planning – Object

Object

These buttons are used to create and manipulate lines and polygons within an existing job. Buttons are enabled/disabled depending on allowed actions. As an example, a line must be activated in order to be able to deactivate it.

The following options are available:

- **New Line:** Create a new line by holding the Ctrl key down while clicking the left mouse button for each new point. At the end of the line, click the right mouse button to accept or cancel the operation.

This option is active until the **New Line** button is pressed again or **New Polygon** is selected.

- **New Polygon:** Create a polygon by holding the Ctrl key down while clicking the left mouse button for each new point in the polygon. Note that a polygon must have at least three nodes. When last point is defined, click the right mouse button, still holding down the Ctrl key, to accept or cancel the operation.

This option is active until the user changes to another option or presses the button once more.

- **New Line From:** Create a new line by entering the start position, it's azimuth and distance. The start coordinates can be given in geographical or projection coordinates.

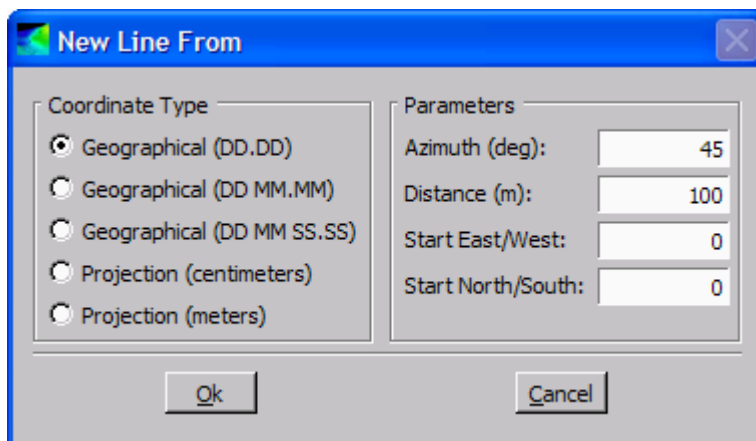

- **New Object:** Create lines or polygons by entering the coordinates. The following features are available:
 - Object type: Select Line or Polygon
 - Coordinate type: Select Geographical or Projection coordinates
 - Name: Give the object an identifying name
 - Add: Add coordinates for a new point
 - Delete: Delete point from the list
 - Up/Down: Change the order of the points

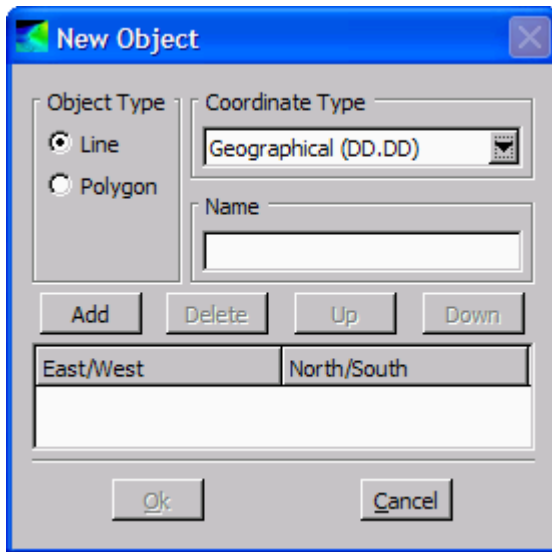

- **Extend Line:** This option is only allowed if one line only is selected.

Press the **Extend Line** button to show the two end points of the line. Select which end you want to extend by holding the Ctrl key down while clicking on it with the left mouse button.

Click the right mouse button to accept or cancel the operation. When accepting, the object is deselected.
- **Activate Line:** First select the line, then press the **Activate Line** button to make the line active. The activated line will have a new colour and be deselected. This line will be sent to the Helmsman display (if present).
- **Deactivate Line:** First select the line, then press the **Deactivate Line** button to make the line inactive. This line will be removed from the Helmsman display (if present).
- **Reverse Line:** Every line has a defined direction, shown by a dot at the start of the line. Pressing the **Reverse Line** button will reverse the direction of all selected lines. Accepting this action will deselect the lines. Click the right mouse button to accept or cancel the operation. When accepting, the object is deselected.

This option is only allowed if one or more lines are selected. Any selected polygons are ignored.
- **Rename:** Press the **Rename** button to open a dialogue where you can change the object's name. The object will remain selected.

This option is only allowed if one object only is selected.
- **Make Parallels:** A user defined number of lines parallel to a selected line can be created using this option. Select a line and then press the button to open the **Parallel Lines** dialogue. This dialogue allow you to define how many lines to create in both directions (port and starboard). The distance and spacing between the lines (in metres) must be specified. Click the right mouse button to accept or cancel the operation. When accepting, the line is deselected.

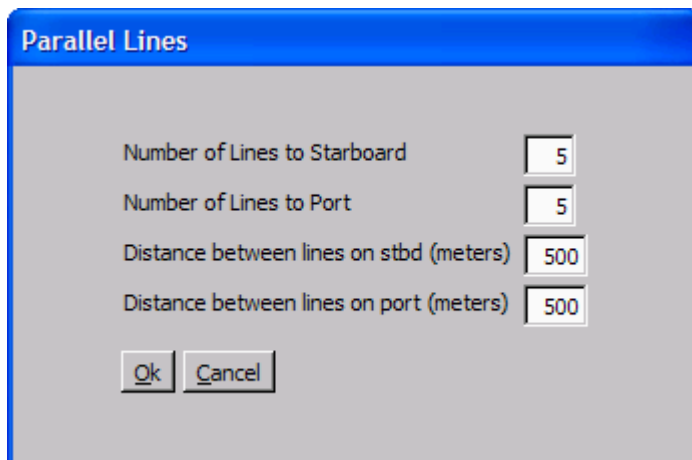

This option is only allowed if one line only is selected. Any selected polygons are ignored.

- **Make Turn:** This option is used to create a turn between two lines. Pressing the **Make Turn** button will create a turn by adding a new line between the end point of the first line and the start point of the second line.

This option is only allowed if two (and only two) lines are selected.

- **Keep Lines Inside:** This option is used to clip the parts of a line lying outside the borders of a polygon.

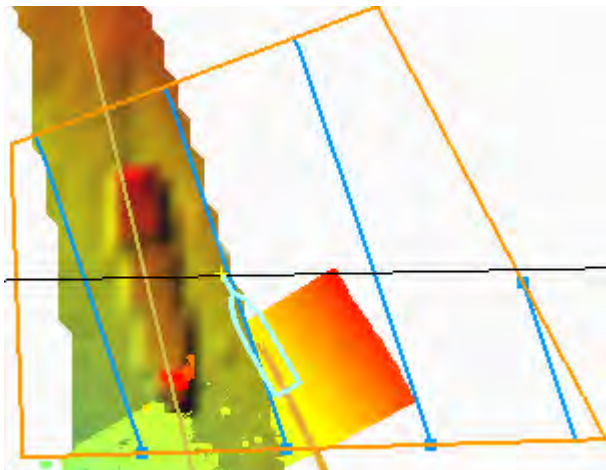

When accepting, the objects are deselected. Multiple lines can be selected.

- **Keep Lines Outside:** This option is used to clip the parts of a line lying inside the borders of a polygon. When accepting, the objects are deselected. Multiple lines can be selected.
- **Fill Polygon:** This option is used to fill a polygon.

Select a polygon and a line and select **Fill Polygon**. This dialogue allow you to define the distance and spacing between parallel lines to be created (both port and starboard directions). The lines will be clipped at the polygon's border. When accepting, the objects are deselected.

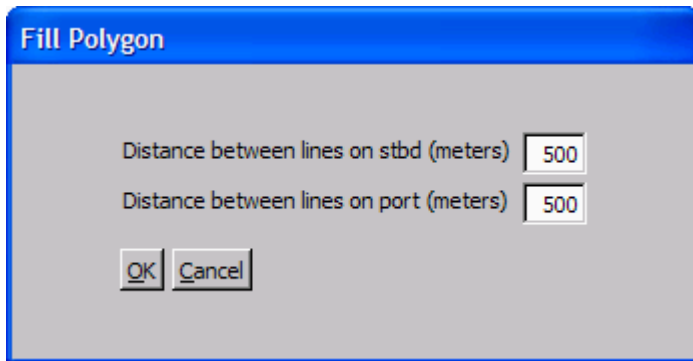

- **Move Point:** Any point can be moved. Select a line or a polygon and press the **Move Point** button to show all points of the selected object. Select which point you want to move by holding the Ctrl key down while pressing the left mouse button and moving the mouse. The selected point will move with the mouse cursor until left mouse button is released. Pressing the left mouse button again elsewhere in the view, will continue moving the point with the mouse cursor until the mouse button is released again. This action needs to be confirmed prior to moving other points. When accepting, the line is deselected.

This option is only allowed if one object only is selected.

Note

It may be difficult to hit a point on an object if the point is directly on top of another object. Zooming in on the point may help.

- **Insert Point:** A point can be inserted to an existing line or polygon. Select a line or a polygon and press the **Insert Point** button to show all points of the selected object. Insert a point by holding the Ctrl key down and clicking on one of the line segments using the left mouse button. After inserting the desired number of points, click the right mouse button to accept or cancel the operation. When accepting, the object is deselected.

This option is only allowed if one object only is selected.

Inserting a point may be found difficult. You may alternatively edit the SIS database as follows:

- 1 Get the current threshold value by calling:

```
getParameter.bat
GEOVIEW_PLANNING_INSERT_VERTEX_THRESHOLD 1
```
- 2 Increase this value by 20 and update the database by calling:

```
"setParameter.bat
GEOVIEW_PLANNING_INSERT_VERTEX_THRESHOLD 1 N"
```

 where "N" is the new value.
- 3 Open the **Show/Hide** button in the **Geographical** display, deselect the **Planning** check box, press **Apply**, then check **Planning** and press **OK**.

If this did not help, try to increase the value a bit more.

- **Delete Point:** Any point can be deleted. Select a line or a polygon and press the **Delete Point** button to show all points of the selected object. Delete a point by holding the Ctrl key down and clicking on it using left mouse button. After deleting the desired number of points, click the right mouse button to accept or cancel the operation. When accepting, the object is deselected.

Note that when deleting points, you must leave at least two points on a line and three points on a polygon.

This option is only allowed if one object only is selected.

Note

If you find it difficult to delete a point in an object, the point may be directly on top of another object. Zooming in on the point may help.

- **Edit Selected:** This option is used for editing objects. Select an object and press the button to open the **Planning Edit Module** dialogue.

This dialogue allow you to change, delete or add points as well as renaming the object. After updating, the object is deselected.

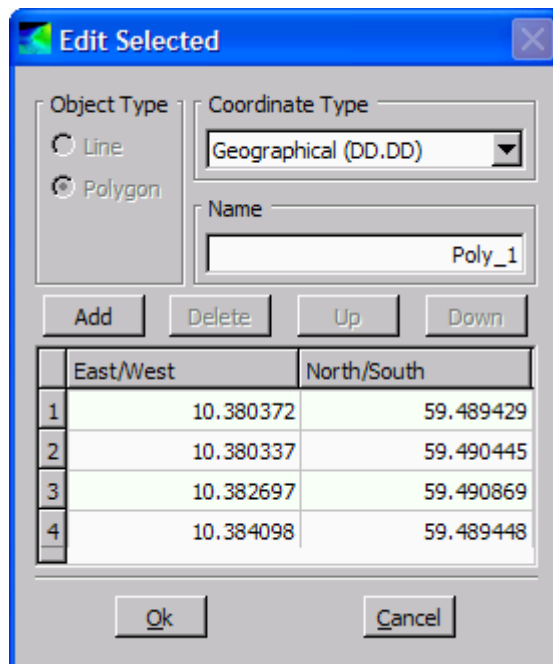

This option is only allowed if an object only is selected.

- **Move Selected:** Any object can be moved. Select one or more objects and press the **Move Selected** button. Move the objects by holding the Ctrl key down, pressing the left mouse button and then moving the mouse. The objects will move with the mouse cursor until releasing the left mouse button.

After moving the objects to the wanted location, click the right mouse button to accept or cancel the operation. When accepting, the objects are deselected.

This option is only allowed if at least one object is selected.

- **Delete Selected:** Press this button to remove all selected objects from memory. No confirmation is required.

This option is only allowed if at least one object is selected.

- **Export Selected:** Press this button to append all selected objects to an already existing job (to file).

This option is only allowed if at least one object is selected.

Sensor layout – Show/hide



Note

Please note that the Sensor layout show/hide menu has a scroll bar that must be used to see all options.

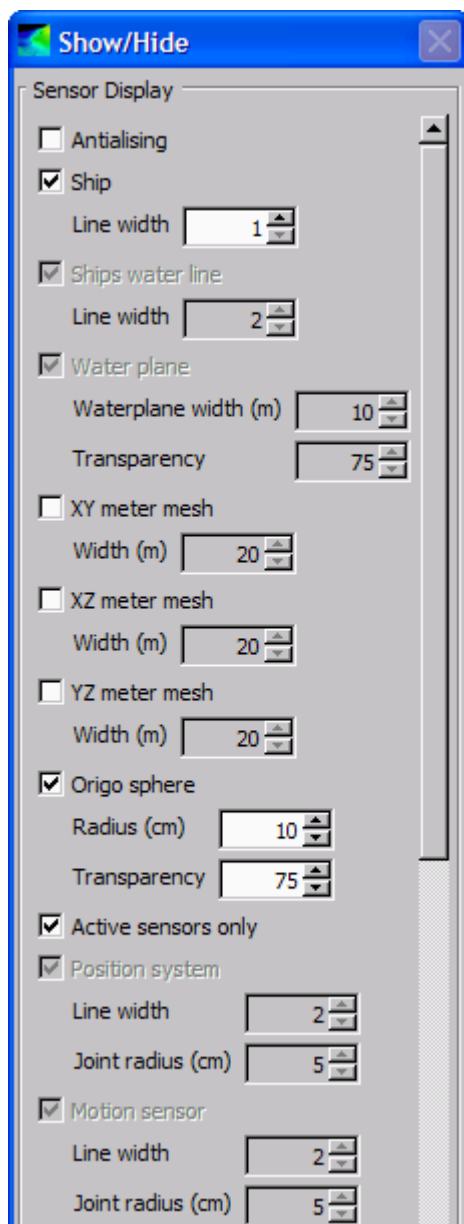

Antialiasing: Apply antialiasing to make the drawing appear smoother on the screen

Ship: Show or hide the ship

- Line width: in pixels

Ships water line: Show or hide the ship's water line

- Line width: in pixels

Water plane: Show or hide the water plane

- Water plane width: in meters
- Transparency: scaled from 1 to 100, where 100 is fully transparent and 1 is not transparent

XY meter mesh: Show or hide mesh in XY plane

- Width (m): Mesh width in metres

XZ meter mesh: Show or hide mesh in XZ plane

- Width (m): Mesh width in metres

YZ meter mesh: Show or hide mesh in YZ plane

- Width (m): Mesh width in metres

Origo sphere: Show or hide the ship's reference point as a small sphere

- Radius (cm): Radius of sphere, max 25 cm
- Transparency: scaled from 1 to 100, where 100 is fully transparent and 1 is not transparent

Active sensors only: Show or hide all system defines sensors

Position system: Show or hide the location of the position system

- Line width: in pixels

- Joint radius (cm): Position system is shown as a sphere with given radius. Max radius is 20 cm

Motion sensor: Show or hide location of motion sensors

- Line width: in pixels
- Joint radius (cm): Motion system is shown as a sphere with given radius. Max radius is 20 cm

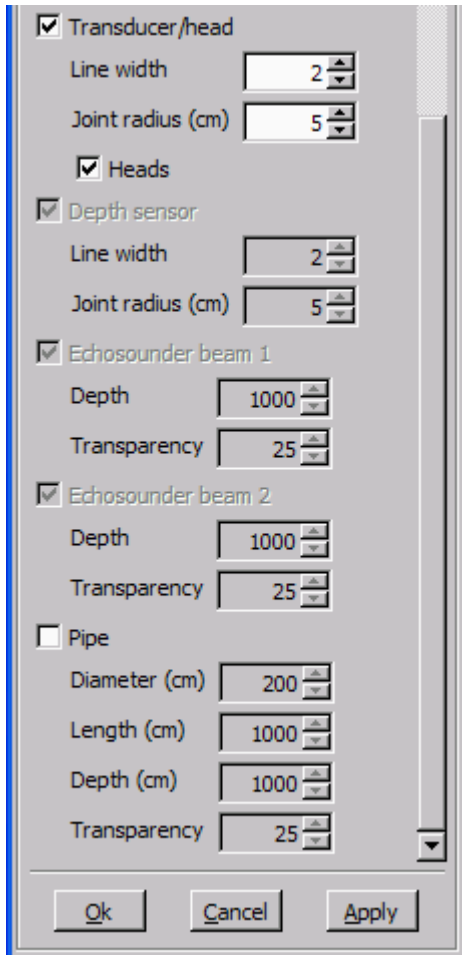

Transducer/head: Show or hide location of transducer or head

- Line width: in pixels
- Joint radius (cm): Transducer or head is shown as a sphere with given radius. Max radius is 20 cm

Depth sensor: Show or hide location of depth sensor

- Line width: in pixels
- Joint radius (cm): Transducer or head is shown as a sphere with given radius. Max radius is 20 cm

Echo sounder beam 1: Show or hide visualisation of beam 1

- Depth: To what depth the beam is visualised (in metres)
- Transparency: scaled from 1 to 100, where 100 is fully transparent and 1 is not transparent

Echo sounder beam 2: Show or hide visualisation of beam 2, if applicable

- Depth: To what depth the beam is visualised (in metres)

- Transparency: scaled from 1 to 100, where 100 is fully transparent and 1 is not transparent

Pipe: Show or hide a visualisation of a seabed pipe

- Diameter (cm): of pipe (true size)
- Length (cm): of pipe
- Depth (cm): of pipe
- Transparency: scaled from 1 to 100, where 100 is fully transparent and 1 is not transparent

Calibration parameters

Related operational procedures

- *How to determine calibration values using SIS Calibration frame on page 181*
- *How to determine calibration values using SeaCal automatic calibration on page 184*

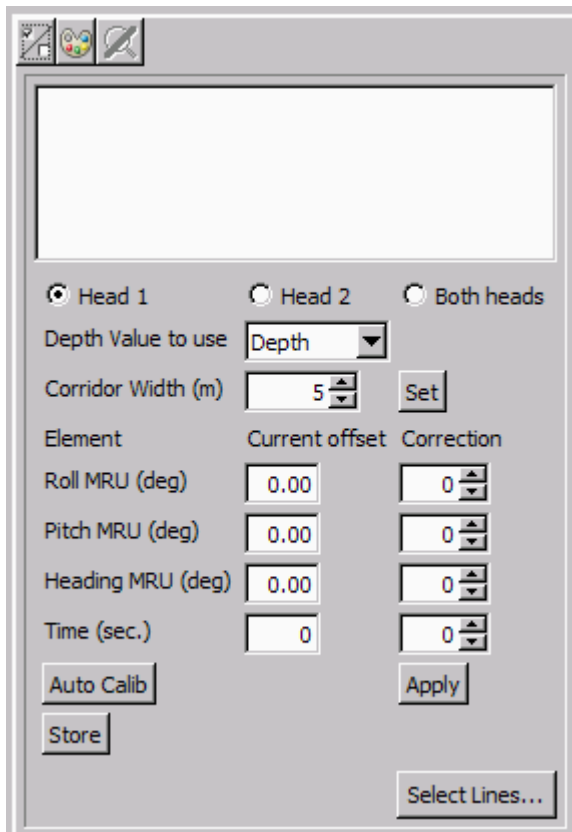

The following calibration parameters may be set:

- **Head 1 / Head 2 / Both heads:** Select the sonar head(s) to be calibrated. Head 2 applies to dual head systems only.
- **Depth Value to use:** Choose between depth, tide corrected depth and depth referred to vertical reference point.
- **Corridor width (m):** Use the slider or the textfield to give a new value. Press **Set** to activate.
- **Current offset:** The Current offsets fields are used to show the offset values used when the data was logged. This field can not be changed.
- **Correction:** Set the correction value you believe give best fit between the curves. Press **Apply** to activate.

Note

Only one element must be corrected for each set of lines

- **Roll MRU (deg):** Use the slider or the textfield to give a new value. Press **Apply** to activate.
- **Pitch MRU (deg):** Use the slider or the textfield to give a new value. Press **Apply** to activate.
- **Heading MRU (deg):** Use the slider or the textfield to give a new value. Press **Apply** to activate.
- **Time (ms):** Use the slider or the textfield to give a new value. Press **Apply** to activate.
- **Auto Calib:** Press this button to launch **Seacal** auto calibration.
- **Store:** Press this button to add the entered calibration values to the existing ones set from **Installation parameters**→**Sensor setup**→**Angular offset**.
- **Select lines...** opens a dialogue box showing all lines in the calibration survey. You may select the lines to compute the calibration values from in the list that appear. Press **OK** to confirm.

Note

*The **Select lines...** dialogue box can only be opened when SIS is in calibration mode.*

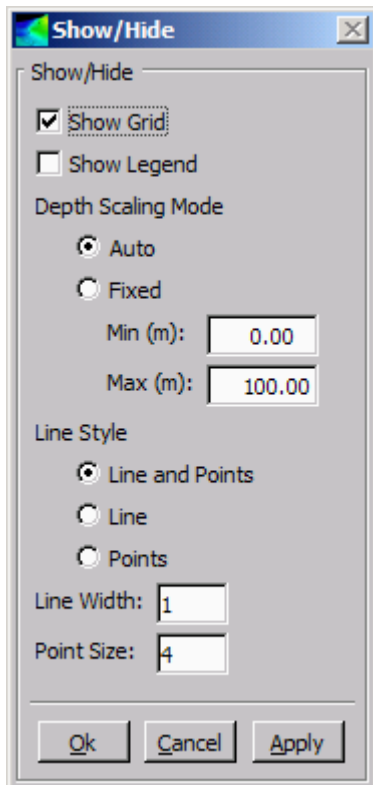
Show/Hide button

Show grid: Show or hide the grid.

Show legend: Show or hide the legends

Depth Scaling mode: Options for controlling the scaling mode for the depth axis.

- Auto - Automatically adjust the start and stop ranges to show the entire range of data each time data is received.
- Fixed - Use the start and stop ranges entered in the min and max text boxes.
 - Min (m): Fixed start (min) range in meters.
 - Max (m): Fixed stop (max) range in meters.

Line style: Select whether to show the calibration lines as lines, points or a combination of both.

Line width: Set line width in pixels.

Point size: Set point size in pixels.

Seacal auto calibration

The following **Auto Calib** parameters can be entered:

- Roll
- Pitch
- Heading
- X0 (translation alongships)
- Y0 (translation athwartships)
- Roll scale
- Y scale
- Relative tide
- Beam sector
- Maximum sea depth

For each parameter to be used, the corresponding On/Off button must be checked.

- **Resolution:** The resolution of the grid model applied in the calculation affects the computing time. The **Auto** option asks **SeaCal** to compute the resolution, but you can also define the resolution manually.

- **Max Iterations:** Usually, SeaCal needs two or more iterations to compute the calibration. You can define the maximum number of iterations manually, or you select Auto, i.e. SeaCal iterates until the solution is stable.
- **Type of computation:** It is also possible to select calibration with or without a reliability test. It is recommended to run this test, as it gives a comprehensive control of the calibration.

Survey parameters

This section contains a description of the dialog boxes and parameter settings provided by the **New survey** and the **Survey administration** frames in SIS.

Topics

- *Basic parameters* on page 263
- *Storage options* on page 265
- *Background data* on page 267
- *Projection parameters* on page 269
- *GridEngine parameters* on page 269
- *User handling* on page 272
- *CUBE parameters* on page 273

The survey parameters that can be set and administrated from these dialogs partly overlap each other, but differs slightly depending on whether a new survey is being set up or the survey parameters are being modified.

Related operational procedures

- *How to enter parameters for a new survey* on page 118
- *How to enter survey parameters* on page 114
- *How to define a new projection and datum transformation* on page 122

Basic parameters

Basic parameters are accessed through **New survey**→**Basic Parameters** .

The survey name is mandatory when creating a new survey. Further, it is required that the parameters for the default surveys are maintained by the user.

The screenshot shows the 'New Survey' dialog box with the 'Basic Parameters' tab selected. The dialog contains the following elements:

- Buttons: 'Save new survey' and 'Continue on existing survey'
- Input fields: 'New Survey name' (text box)
- Dropdown menus: 'Select survey-template' (Default), 'User' (SIS user), 'Existing Surveys'
- Text area: 'Comment'

Parameters

- **New Survey name:** Give a unique name to your survey (mandatory)
- **Select survey-template:** Loads **Storage** and **Advanced Options** parameters defined in a template
- **User:** Select the identification of the user. To add new user(s), refer to *User handling* on page 272.
- **Existing Surveys:** Select an existing survey. Press **Continue on existing survey** button before the survey can be changed
- **Comment:** Give additional information about the survey
- **Save new survey:** Create the new survey. All parameters stored under the **Storage options** tab and the **Advanced options** tab are stored in the database for this new survey

The **Basic parameters** are also located under the **Survey templates handling** tab in the **Survey administration** frame. The look and parameters differs slightly from when accessed from **New survey**.

The Survey template handling manages the default surveys used as template.

The screenshot shows a web-based interface for 'Survey administration'. At the top, there are three tabs: 'User handling', 'Background data', and 'Survey templates handling'. The 'Survey templates handling' tab is selected. Inside this tab, there are three sub-tabs: 'Basic Parameters', 'Storage options', and 'Advanced options'. The 'Basic Parameters' sub-tab is active. It contains the following elements:

- Add/Change survey template** section:
 - 'New Survey template': A dropdown menu.
 - 'Select survey-template': A dropdown menu with 'Default' selected.
 - 'User': A dropdown menu with 'SIS user' selected.
 - 'Comment': A large text input area.
 - 'Update': A button.
- Delete survey template** section:
 - 'Survey template': A dropdown menu with 'empty' selected.
 - 'Delete': A button.
- Survey type as default** section:
 - 'Survey type as default': A dropdown menu with 'Default' selected.

Parameters - Add/Change survey template

- **New Survey name:** Select the survey you want to add/change from
- **Select survey-template:** Select a survey template you want the new template to be based upon for the parameters for **Storage options** and **Advanced options**.

- **User:** Select a user. To add new user(s), you must use the **User handling** tool, see *User handling* on page 272.
- **Comment:** Write your own comment for the survey template
- **Update:** Update the existing default survey or add a new default survey to the database. This includes the parameters stored under the **Storage options** tab and the **Advanced options** tab.

Parameters - Delete survey template

- **Survey name:** Select the survey you want to delete
- **Delete:** Delete the selected survey

Parameters - Survey type as default

- **Default/Previous:** Define which default survey is to appear in the **Select survey-type** combo box

Related operational procedures

- *How to enter parameters for a new survey* on page 118
- *How to enter survey parameters* on page 114

Storage options

Storage options are accessed through the **New survey** frame or through the **Survey administration** frame on the **Survey template handling** tab.

Observe the default storage locations of raw and gridded (survey) data. We recommend that you stick to the default storage structure, unless you have specific requirements. Sub-directories will be added according to your selections in the raw data structure dialog field.

The screenshot shows the 'New Survey' dialog box with the 'Storage options' tab selected. The 'Survey data storage location' is set to 'C:\sisdata\grids' and the 'Raw data root location' is 'C:\sisdata\raw'. The 'Current rawdata storage structure' is 'SURVEYNAME'. There are buttons for 'Use current structure' and 'Clear new structure'. The 'Build rawdata storage structure from tickboxes' section has checkboxes for SHIP, YEAR, MONTH, SOUNDERTYPE, SERIALNUMBER, and DAY. The 'Shipname' field contains 'ShipName' and the 'Use as postfix in filename' checkbox is checked. An 'Apply to all survey templates' button is at the bottom.

Parameters

- **Survey data storage location:** Specify the location to store Survey Data files. Enter the folder identification directly, or use the browse button to navigate
- **Raw data root location:** Specify the location to store Raw Data files. Enter the folder identification directly, or use the browse button to navigate. Press the **Apply to all default surveys** button to apply
- **Current raw data storage structure:** Description of current structure
- **Use current structure:** Keep current structure
- **Clear new survey:** Create a new structure
- **Build raw data storage structure from tickboxes:** Build a new storage structure by enabling the check boxes you want to use. The new structure will appear in the text field behind **New raw data storage structure**
- **Shipname:** To identify the data files by your ship's name if the **Use as postfix in filename** check box is ticked off
- **Apply to all survey templates:** Update these parameters for all survey templates in the database. If you want to store these parameters to a particular survey, you must select a different survey template from the **Basic Parameters**

Related operational procedures

- *How to enter parameters for a new survey* on page 118
- *How to enter survey parameters* on page 114

Background data

Background data is found under three different tabs under the **New survey** and under the **Survey administration** display view:

1 Survey Administration→Background data

The **Background data** tab located directly under the **Survey Administration** frame is used for enabling and disabling file locations where your background data is stored.

2 Survey Administration→Survey templates handling→Advanced options→Background data

This is where you select the background data you want to use for the survey template you currently are setting up.

3 New survey→Advanced options→Background data

This is where you select the background data you want to use for the survey you currently are setting up.

The **Background data** dialog boxes selected from (2) and (3) above appears identical, but applies to the survey template or current survey depending of where you are accessing the dialog from. The parameters from this dialog box are described in the following.

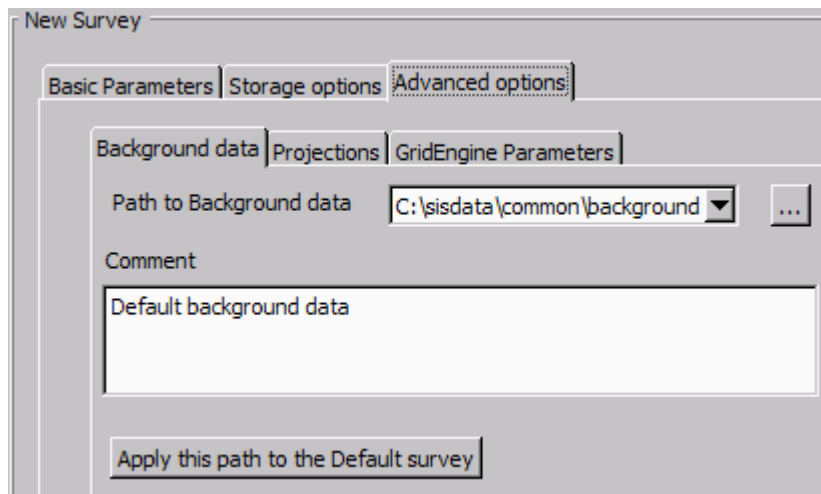

Parameters

- **Path to Background data:** Choose the path you want to use for the background data. You can use the browse button to find a path
- **Comment:** Write your own comment for the background data
- **Apply this path to Default survey:** Apply the path.

If you want to store these parameters to a particular survey, you must use the **New Survey→Basic parameters** or **Survey Administration→Basic parameters**.

In the background data directory the following files can be stored:

- Projection setup: **proj.txt** used to define the geographic projection for the survey.
- KSGPL background data: ***.ksgpl**. KSGPL formatted files with background data to be shown in the Geographical display.
- Predicted tide: **predictedtide.tide**, predicted tide file.

- Geoid model: **geoidmodel.geoid**, geoid model.

Background data can also be accessed from **Survey administration** frame and is used for enabling and disabling file locations where your background data is stored.

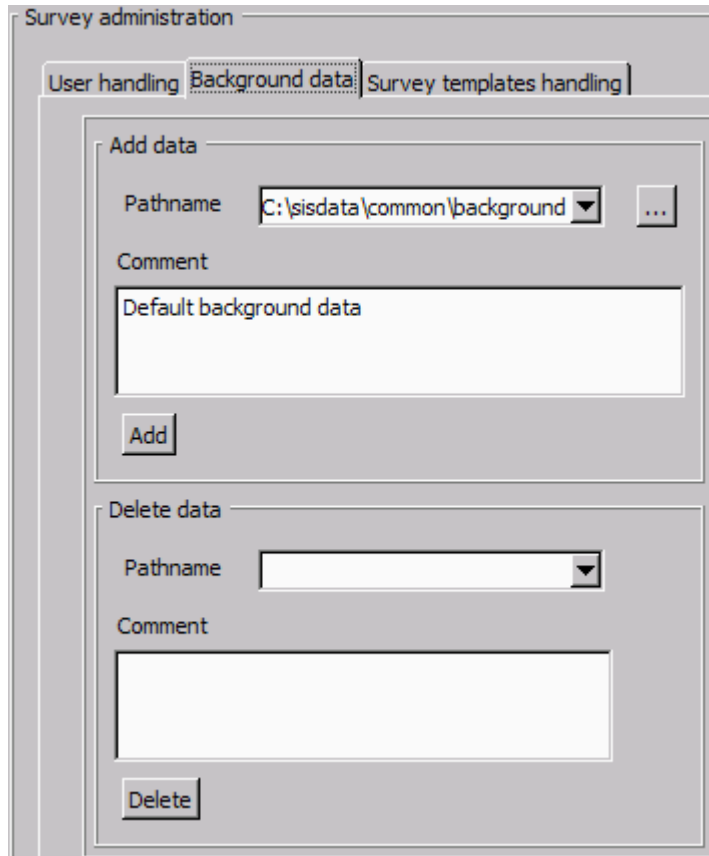

Parameters – Add data

- **Pathname:** Set the path to the background data
- **Comment:** Write your own comment for the background data
- **Add:** Add the selected path

In the background data directory these files can be stored:

- Predicted tide: `predictedtide.tide`, predicted tide file.
- Geoid model: `geoidmodel.geoid`, geoid model.
- Background image: Tiff and geotiff files.

If you want to store these parameters to a particular survey, please refer to *Basic parameters* on page 263.

Parameters - Delete data

- **Pathname:** Select the path you want to delete from the combo box
- **Comment:** See information given about the selected path
- **Delete:** Delete selected path

Related operational procedures

- *How to enter parameters for a new survey* on page 118
- *How to enter survey parameters* on page 114

Projection parameters

Projections is located under the **Advanced options** tab on the **New survey** display view and under the **Advanced options** tab under the **Survey templates handling** tab on the **Survey administration** display view.

When defining a survey or a survey template, you have to define what projection to use in that survey or survey template. New projections can be created and tested using the **Projection setup** application available from the **Tools**→**Custom** menu.

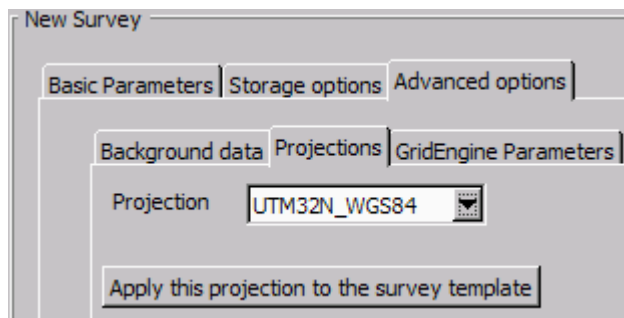

Parameters

- **Projection:** Select a projection from the drop-down combo box
- **Apply this projection to the Default survey:** These projections will be saved in the database for all default surveys

If you want to store these parameters to a particular survey, you must use the **New Survey**→**Basic parameters** or **Survey Administration**→**Basic parameters**.

If a survey is loaded into SIS, the user is prompted to change projection. If yes, all earlier surveys loaded into SIS will be removed, before activation of the new survey.

It is possible to change projection after a projection has been set.

Related operational procedures

- *How to define a new projection and datum transformation* on page 122

GridEngine parameters

The **GridEngine parameters** is located under the **Basic Parameters** tab on the **New survey** display view and under the **Advanced options** tab under the **Survey templates handling** tab on the **Survey administration** display view.

When defining a survey or a survey template, you have to define what parameters to use for the GridEngine.

Parameters

The terrain modelling module in SIS uses an internal Processing Grid. Nine Processing Grids may be loaded into RAM simultaneously. The Processing Grid is a square, and the size of one side should be approximately the expected swath width.

The following factors have influence on the selection of the cell number and cell size:

- Depth
- Achieved swath width (shown in numerical display)
- Survey speed
- Coverage area per beam (footprint)

If the cell size is set too large the resolution in your geographical view will be poorer than necessary. If you set the cell size too small you may experience that there are not sufficient data points in the cells to compute a valid depth value, and no depth value is displayed. Too small cell size may also overload the computer and give you delays in the real time display.

Note

The grid resolution applies to displayed data only, the raw data is not affected.

The grid resolution can not be changed during the survey, and should therefore be carefully set to apply to the whole survey area.

The following rule of thumb have proven to be reasonable:

Normal resolution

- Cell size = average swath width/100
- Number of cells in processing grids: 64x64

High resolution

- Cell size = average swath width/200
- Number of cells in processing grids: 128x128

Example: If depth is 100 meters and sector coverage is set to $\pm 70^\circ$, the swath width is 550 meters. Cell size computed from above rule of thumb for may then be set to 5.5 meters for normal resolution and 2.8 meters for high resolution.

Note

The cell size settings applies to highest possible display resolution, i.e. LOD0.

- **Depth variable:** If you are applying real time data cleaning, select what depth to use in the processing.

The real time data cleaning module will use the given depth plane to identify outliers in the data and remove them.

Note

We recommend that you set the real time data processing depth to either tide corrected depth, Z_v , or to geoid and RTK corrected depth, Z_v , in order to avoid unwanted depth rejections caused by natural variations such as the tide.

The depth variable can be set to:

- Z: Depth, sea surface to sea bottom distance.
 - Zt: Tide file corrected depth, vertical datum to seafloor distance.
 - Zv: Geoid and RTK corrected depth, vertical datum to seafloor distance.
 - Zg: Seafloor to geoid distance.
 - Zr: Seafloor to ellipsoid distance.
- **Number of cells:** Set number of cells in the processing grid:

- 16 x 16
 - 32 x 32
 - 64 x 64
 - 128 x 128
 - 256 x 256
 - 512 x 512
- **Cell size (cm):** Set the cell size (in m). The selectable range is from 0.1 to 150 m
 - **Processing parameters:** Set the Ping processing and Grid processing rules. These rules are explained under the **Data Cleaning** tab. See *Data cleaning* on page 317
 - **Apply to all survey templates:** This will update the grid engine parameters for all survey templates currently in the database.

If you want to store these parameters to a particular survey, you must use the **New Survey**→**Basic parameters** or **Survey Administration**→**Basic parameters**.

Related operational procedures

- *How to enter parameters for a new survey* on page 118
- *How to enter survey parameters* on page 114

User handling

User handling is located under the **Survey administration** display view.

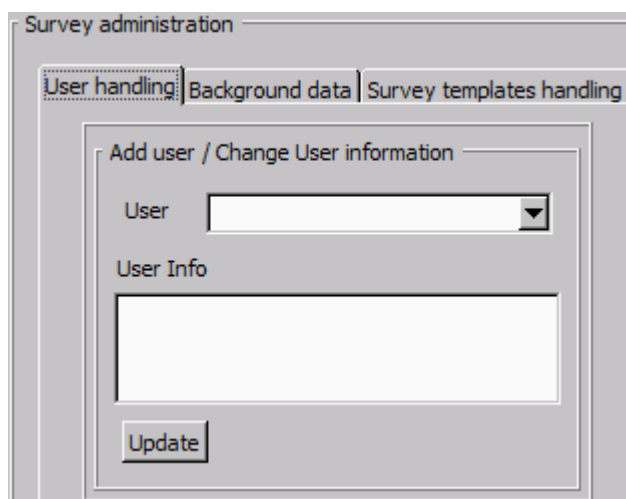

Parameters – Add user/Change user information

- **User:** Type the name of the new user
The user parameter is logged in the raw survey format files (.all-files). This makes it possible to recall who was responsible for the survey.
- **User Info:** Type any additional information about the user
- **Update:** Apply your changes

Related operational procedures

- *How to enter survey parameters* on page 114

CUBE parameters

The CUBE (Combined Uncertainty and Bathymetry Estimator) algorithm is developed at The Centre for Coastal and Ocean Mapping (C-COM)/Joint Hydrographic Centre (JHC) at University of New Hampshire. The algorithm is available as a library and is used inside one separate module in SIS. The CUBE algorithm can be used as an alternative data gridding and data cleaning method in SIS. The gridding and data cleaning is a default process done by the GridEngine.

A CUBE grid can be generated for all the raw data files in a survey when logging is completed. This requires that all necessary parameters are defined in the survey template.

The screenshot shows a multi-level menu system for 'Survey administration'. The top level includes 'User handling', 'Background data', and 'Survey templates handling'. The 'Survey templates handling' menu is open, showing 'Basic Parameters', 'Storage options', and 'Advanced options'. The 'Advanced options' menu is also open, showing 'Background data', 'Projections', 'GridEngine Parameters', and 'Cube parameters'. The 'Cube parameters' window is active, displaying the following fields:

Cube parameters		
Depth variable:	<input type="text" value="Z"/>	
Origin North	<input type="text"/>	deg.decimal degree
Origin East	<input type="text"/>	deg.decimal degree
Width	<input type="text"/>	km
Height	<input type="text"/>	km
Grid cell size	<input type="text"/>	meter

Related topics

- *CUBE* on page 464

Related operational procedures

- *How to enter survey parameters* on page 114

Installation parameters

This section contains a description of the dialog boxes and parameter settings provided by the **Installation parameters** frame in SIS.

Note

*Any changes to the installation parameters have to be confirmed. When a parameter value has been changed the **OK** button turns yellow. You have to confirm your change by pressing the yellow **OK** button. The button will return to its original colour.*

Note

*Whenever the **OK** button is pressed from the **Installation parameters** frame a backup file containing current PU parameters is generated. The backup file can be Imported through **File**→**Import PU parameters...** The backup files are stored in `\sisdata\common\backup-settings` with the naming convention `Backup_<echo_sounder_name>_<serial number>_<YearMonthDay>_<HourMinuteSecond>.txt` e.g. `Backup_EM_2040_402_20090430_105852.txt`.*

Note

*The **PU – Processing Unit** may be a separate hardware unit or an integrated part of the **TRU – Transceiver Unit** cabinet, depending on echo sounder system.*

For SIS it makes no difference whether the communication is with a PU or a PU inside a TRU. The term PU is used in this manual.

Topics

- *PU communication – Input setup on page 275*
- *PU communication – Output setup on page 279*
- *PU communication – Clock setup on page 281*
- *Sensor setup – Settings on page 283*
- *Sensor setup – Location for EM 2040 on page 288*
- *Angular Offsets for EM 2040 on page 290*
- *ROV Specific for EM 2040 on page 291*
- *System parameters for EM 2040 on page 292*
- *BIST – Built-In Self Test on page 293*

Related operational procedures

- *How to open the installation parameter interface on page 127*
- *How to modify the installation parameters on page 127*

PU communication – Input setup

Input Setup is located under the **PU Communication Setup** tab on the **Installation parameters** display view and is used to define the communication parameters for input data to the PU.

Note

When Input Setup configuration is changed, you should check that the parameters in the Sensor setup tab still applies.

The screenshot shows a 'Port settings' dialog box. At the top, there is a 'Port:' dropdown menu currently set to 'COM1'. Below this, the dialog is divided into two main sections: 'Com. settings' and 'Input Formats'. The 'Com. settings' section contains four dropdown menus: 'Baud rate' (set to 9600), 'Data bits' (set to 8), 'Stop bits' (set to 1), and 'Parity' (set to NONE). The 'Input Formats' section contains a 'Position' radio button group with 'None', 'GGK', 'GGA' (selected), 'GGA_RTK', and 'SIMRAD90'. To the right of the radio buttons are several checkboxes: 'Attitude', 'ZDA Clock', 'HDT Heading', 'SKR82 Heading', 'MK39 Mod2 Attitude, no heave', 'DBS Depth', 'DBT Depth', 'EA500 Depth', 'ROV. depth', and 'Height, special purpose only'.

Input setup parameters – Port settings

Port

Input port: This drop-down combo-box is used to select which of the PU (Processing Unit) ports the dialogue box is applicable to. Choose between the serial ports COM1 to COM4 or the network ports UDP2, UDP5 or UDP6.

- COM1: Normally used for position, clock and depth input.
- COM2: Designated to input from a motion sensor.
- COM3: Optional (position, motion and heading input).
- COM4: Optional (position and heading input).
- UDP2: Attitude/Position and EA 500 depth input.
- UDP5: Attitude velocity input 1 (applies to EM 122, EM 302, EM 710, EM 2040 and EM 2040C)
- UDP6: Attitude velocity input 2 (applies to EM 122, EM 302, EM 710, EM 2040 and EM 2040C)

COM port settings:

- **Baud rate:** Define the baud rate for the currently selected serial port.
- **Data bits:** Select the number of data bits for the currently selected serial port.
- **Stop bits:** Select the number of stop bits for the currently selected serial port.
- **Parity:** Select the parity for the currently selected serial port.

UDP port settings

The UDP port settings are given by the PU status and information datagram broadcasted by the PU.

The port settings are as follows:

Port	Port number
UDP2:	2022
UDP3:	2032 (not used)
UDP4:	2042 (not used)
UDP5:	Defined by attitude velocity sensor 1
UDP6:	Defined by attitude velocity sensor 2

Network addresses

Caution

You must ensure that the network addresses and ports are not used by other systems.

The Ethernet 1 network addresses for the different Kongsberg Maritime echo sounders are as follows:

System	Network address
EM 120:	157.237.14.60
EM 122:	157.237.14.60
EM 300:	157.237.14.60
EM 302:	157.237.14.60
EM 710:	157.237.2.71
EM 1002:	157.237.15.60
EM 2000:	157.237.2.58
EM 3000:	157.237.2.58
EM 3002:	157.237.2.61
EM 2040 / EM 2040C:	157.237.20.40
ME70/BO:	Defined by the Simrad ME70/BO system

UDP5/UDP6 Setup – Attitude velocity settings

When you set the **Input port** to **UDP5** or **UDP6** an additional dialog appears.

The system may be configured with one or two standard motion (attitude) sensors via COM ports. Both these sensors can also provide attitude velocity via UDP ports:

- UDP5 is associated with Attitude 1 using the setup information (i.e. location information) for Attitude on COM2.
- UDP6 is associated with Attitude 2 using the setup information (i.e. location information) for Attitude on COM3.

See *Sensor setup – Location for EM 2040* on page 288

Settings for both UDP5 and UDP6 ports are displayed simultaneously, but only the settings for the selected port (UDP5 or UDP6) can be changed, the other is disabled (greyed out). Also note that the Ethernet 2 settings, i.e. IP address and Net mask, may only be changed if the Use Ethernet 2 tick button has been set.

- If input from an Attitude Velocity sensor is required **Attitude/Velocity** in the **Input format** list must be ticked off. If not enabled, no UDP5 or UDP6 parameters will be received by the PU.
- **Use Ethernet 2** defines if the PU Ethernet 2 port is to be used or not. If not selected the sensor input is assumed to go via Ethernet 1 (same as used for the HWS). It is recommended to use Ethernet 2 for the attitude velocity. The UDP port number will be used in any case. The Ethernet 2 settings are the same for both UDP5 and UDP6.
- **IP addr.** sets the IP address to be used by the PU Ethernet 2 port. **Net mask** sets the net mask to be used. The IP address and network mask must be in the same subnet as the sensor.
- **UDP port settings** set the UDP port number used by the attitude velocity sensor when transmitting data according to the following available settings:

Sensor	Port number
Kongsberg Seatex Seapath 200:	3001
Applanix POSMV:	5602
CodaOctopus F180:	3000

Note

The Ethernet 2 settings are the same for both UDP5 and UDP6. Some Attitude/Velocity sensors have a hard coded port address. This restricts the use to only one such sensor in a two sensor configuration.

Note

When an Attitude/Velocity setup change has been completed in the Port Settings group it is necessary to check the Active Sensors selection group in the Installation and Test →Sensor Setup →Settings frame to make sure that the correct sensor is set as active.

As a reminder the Sensor →Sensor Setup tabulators are coloured red to advice the operator to check, and possibly modify, the selections.

Input formats

This area allows you to define what type of external sensor is connected to the serial or network port you selected in the **Input port** combo box.

Inputs in the following formats are available:

- GGK Positions (NMEA)
- GGA Positions (NMEA)
- GGA_RTK Positions (NMEA)
- Simrad90 Positions
- Attitude
- ZDA Clock (NMEA)
- HDT Heading (NMEA)
- SKR82 Heading
- MK39 Heading
- Ethernet AttVel
- DBS Depth (NMEA)
- DBT Depth (NMEA)
- EA500 Depth
- ROV Depth
- Height (special purpose only)

Refer to the Datagram Formats in the appropriate user documentation for a description of these formats.

Restrictions to sensor input

A number of restrictions apply to the selection of the PU (Processing Unit) input formats. These restrictions are integrated into the user interface and will be reflected in the enabling/disabling of check boxes for the different ports. The restrictions are as follows:

- Only one positioning system is allowed on each port, with a maximum of three positioning systems
- Positioning system 1 is by definition on COM1
- Positioning system 2 is by definition on COM3
- Positioning system 3 is by definition on COM4 or UDP2
- Only one motion sensor is allowed on each port, with a maximum of two motion sensors
- Motion sensor 1 is by definition on COM2
- Motion sensor 2 is by definition on COM3
- A motion sensor cannot share a serial line (COM) with other sensors
- The Sperry MK39 MOD2 motion sensor (roll, pitch, heading) can only be used on serial line COM3
- A stand alone heading sensor using SKR80/82 format can only be used on a COM (serial line) port. This port cannot be shared by others sensors when in use
- A stand alone heading sensor using SKR80/82 format can only be used on a COM (serial line) port. This port cannot be shared by others sensors when in use
- Only one clock input (normally ZDA) is allowed plus a single 1PPS clock sync. signal. See *PU communication – Clock setup* on page 281
- Only one depth sensor is allowed (pressure sensor for ROV)
- The EA500 format can only be used on UDP2

PU communication – Output setup

Output Setup is located under the **PU Communication Setup** tab on the **Installation parameters** display view.

Output setup is used to defined what datagrams to be output from the PU (Processing Unit) to the following:

- SIS raw data logging
- Raw data logging to PU disk
- User defined selection to third party systems (e.g. QINSy or HYPACK)

Enabling of water column data logging to separate file is enabled from here.

The screenshot shows a configuration window for the Seafloor Information System. On the left, there are several options: 'UDP Host Port' is set to 'SIS Logging', 'Port addr.' is '16149', 'Enable PU logging to disk' is unchecked, 'Log watercolumn to separate file' is unchecked, and 'PU broadcast enable (on port:1999)' is checked. On the right, a 'Datagram subscription' box contains a list of datagrams with checkboxes: Depth, Raw range and beam angle, Seabed Image, Central Beams (unchecked), Position, Attitude, Heading, Height, Clock, Single beam echosounder depth, Sound Speed Profile, Runtime Parameters, Installation Parameters, BIST Reply, Status parameters, PU Broadcast, Detection quality, and Internal, Scope Data.

Output setup parameters

UDP host port: Available options depend on system connected.

- **SIS Logging** is used by the system to define what SIS raw data to log. The settings for this link should normally not be changed. Mandatory datagrams are disabled from deselecting
- **User defined** can be set up to contain any datagrams selected from the list. By using the given port address these datagrams can be picked up by any third party systems with access to the same network.

Port address: Can NOT be changed.

Note

Port number 2999 is reserved for internal use.

Log watercolumn to separate file enables logging of water column data to a *.wcl file. Water column data file locations is set from the **Tools**→**Custom**→**Set Parameters** menu.

See *How to log water column data* on page 170 for details.

Enable PU logging to disk applies to systems where internal logging to PU disk is possible.

PU broadcast enable: Tell the PU (Processing Unit) to broadcast its presence on the network, using port 1999. The PU will send out a broadcast datagram every second to port 1999. This function can not be turned off.

Datagram subscription on the UDP port: The table below shows datagram subscriptions available for various multibeam echo sounders.

Datagram	Echo sounder											
	EM 120	EM 122	EM 300	EM 302	EM 710	EM 1002	EM 2000	EM 3000	EM 2040	EM 2040C	EM 3002	ME70 /BO
Depth	x	x	x	x	x	x	x	x	x	x	x	x
Raw range and beam angle	x	x	x	x	x	x	x	x	x	x	x	x
Seabed image	x	x	x	x	x	x	x	x	x	x	x	x
Central beams	x		x									
Position	x	x	x	x	x	x	x	x	x	x	x	x
Attitude	x	x	x	x	x	x	x	x	x	x	x	x
Heading	x	x	x	x	x	x	x	x	x	x	x	x
Height	x	x	x	x	x	x	x	x	x	x	x	x
Clock	x	x	x	x	x	x	x	x	x	x	x	x
Single beam echo sounder depth	x	x	x	x	x	x	x	x	x	x	x	x
Sound Speed Profile	x	x	x	x	x	x	x	x	x	x	x	x
Runtime parameters	x	x	x	x	x	x	x	x	x	x	x	x
Installation parameters	x	x	x	x	x	x	x	x	x	x	x	x
BIST Reply	x	x	x	x	x	x	x	x	x	x	x	x
Status parameters	x	x	x	x	x	x	x	x	x	x	x	x
PU broadcast	x	x	x	x	x	x	x	x	x	x	x	x
Detection quality		x		x	x				x	x	x	
Stave display		x		x	x				x	x	x	
Water column		x		x	x				x	x	x	x
Hull unit						x						
Internal, Scope Data	x	x	x	x	x	x	x	x	x	x	x	x

Related procedures

- *How to log water column data* on page 170
- *How to log stave data* on page 170

PU communication – Clock setup

Clock Setup is located under the **PU Communication Setup** tab on the **Installation parameters** display view.

Clock Setup is used to set the PU clock based on selected input source.

Please refer to *Timing* on page 498 for detailed description about timing in SIS.

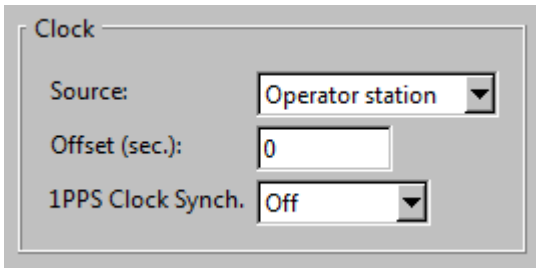

The echo sounder system has an internal clock with 1 millisecond resolution. This clock is used to time stamp all logged data. The clock will drift, typically some seconds per day, unless it is synchronized to a 1PPS (one pulse per second) input signal. The 1PPS signal will determine the clock's drift rate, and in practice reduce it to zero using a GPS receiver as source.

The clock may be set in three situations:

- 1 When the PU is initialized during start-up of PU from SIS.
- 2 When the Clock Source is changed.
- 3 When a new survey is started.

A fully correct clock is only necessary if the output data are later to be combined with other time critical data logged or created by other systems, for example an accuracy of up to one minute would be necessary to apply tidal changes.

If the timestamp supplied in the position input datagrams is to be used, it is imperative that the system clock is correctly set and that 1PPS synchronization is used.

Clock setup parameters

Source: This selector is used to define the source for the synchronization of date and time. The following options are available:

- External ZDA clock (UTC time received in ZDA format)
- Active Positioning System (time stamp of position datagram)
- Operator Station
- No sync

Note _____

External ZDA can only be selected if ZDA input is selected. See PU communication – Input setup on page 275.

*When **External ZDA clock** is selected both the PU Communication Setup and the Clock Setup tabulators are changed to red to indicate that you need to check current clock setup.*

The red tabulator setting is turned off when the OK or the CANCEL button is pressed

In the case that the ZDA Clock input is turned off and the clock source setting is External ZDA Clock the (fall back) clock source is automatically set to Active pos. system.

Offset [sec]: Offset (sec) is used if you want to refer to a different time zone than your time reference. This may be useful e.g. if you have tide data referred to Local time, whereas you are synchronizing to UTC time.

It is possible to use the **Offset** to adjust the echo sounder clock to a local time zone. If a local time zone is set, there are restrictions: **Time to use** located under the **Sensor setup**→**Settings** tab for active positioning must be set to **System**. If not, no data will be displayed in the geographical view. The data it self will be correct regardless of the selected Time to use. The problem is that SIS will not take the time offset into account when reading position time tags.

1PPS Clock Sync: This selector is used to turn on the 1 pulse per second external clock synchronization and select if the synchronisation should occur on a rising or falling edge transition. The following options are available:

- **Off** the 1 pulse per second external clock synchronization is turned off (this is the default value)
- **Falling edge** synchronisation on a falling edge transition
- **Rising edge** synchronisation on a rising edge transition

1PPS input signal is normally “resting” at a high level. Each second, a low going 100 mS-1000 mS pulse adjusts the second counter in the PU (Processing Unit). Since 1PPS is a TTL-signal, a high level at the input connector must be higher than 2.7 Vdc (the margin is then 0.3 Vdc) and a low level (during the pulse) must not exceed 0.6 Vdc (the margin is then 0.2 Vdc).

Sensor setup – Settings

Settings (of sensors) is located under the **Sensor Setup** tab on the **Installation parameters** display view and contains the following dialog fields:

- Position system settings
- Motion system settings
- Active sensors

Note

When the Input Setup configuration is changed the Settings must be verified!

Positioning systems parameter settings

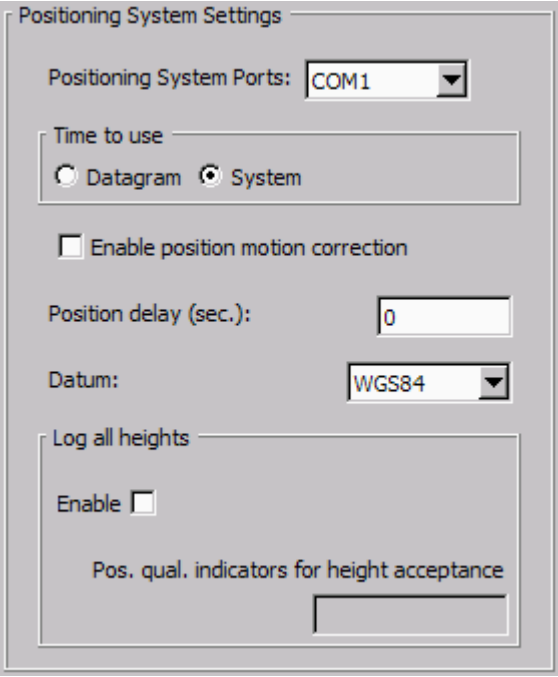

You can connect three positioning systems to the multibeam echo sounder, but only one can be active at a time. One positioning system can be connected using a network port instead of a serial line.

Data from all positioning systems are logged, and may all be used in post-processing. However, only the positioning system selected as active will be used in the realtime displays. (See *Active sensors parameter settings* on page 287).

For each of these positioning systems, some basic parameters must be defined.

Positioning System Ports: Use this drop-down combo box to choose which positioning system you wish to set the parameters for. The positioning system is not identified by its name, but by the port it is connected to.

The following ports are available:

- COM1 (positioning system 1)
- COM3 (positioning system 2)
- COM4 (positioning system 3)
- UDP2 (positioning system 3)

Time to use: Usually the input datagram's timestamp is used. However, it is then assumed that the multibeam echo sounders clock is set from **External ZDA clock**, that both the PU system clock and the positioning system clock are synchronized with the 1PPS signal and that there is no time difference between the two clocks.

Any time difference can be set from the **Installation parameters**→**PU communication setup**→**Clock setup tab**. This is also where you set the PU clock to be synchronized with **External ZDA clock**.

Select Datagram or System:

- **Datagram:** The time of the observation read from the position datagram.
- **System:** The multibeam echo sounder will use its own internal time stamp when applying positions to the real time display.

Note

Both time stamps are stored, hence the time reference can be changed or corrected in post processing.

Enable position motion correction: When the vessel moves due to roll, pitch and heave, the antenna on the positioning system moves as well. This parameter allows the system to compensate for this movement by adjusting the values from the positioning system based on current information from the motion sensor(s).

Correct timing of the positions is very important if motion correction is to improve position accuracy.

Position delay (sec): This parameter is used to define the age of the position in the position datagrams.

The relative timing of vessel position data and system depth data is critical to the total achievable accuracy. The best solution is if it can be assured that the position datagrams are always received by the system with a fixed and sufficiently constant age with respect to the time of validity of the enclosed positions. This age is the position delay to be entered. Such a solution will make the use of any clock synchronization of the system with the positioning system unnecessary.

Datum: This parameter enables you to set the internal datum identical to what the positioning system sends to the echo sounder. This will also be logged onto the harddisk. The projection reference in the survey module must also be set accordingly.

Log all heights: When enabled the PU will send height datagrams for the selected positioning system, i.e. the COM port selected.

Pos. qual. indicators for height acceptance: Enter the quality indicator numbers (comma separated) that you want to interpret as accepted height observations. The quality factor applies to GGA and GGK position data only.

Attitude sensor parameter settings

You can connect two motion systems to the multibeam echo sounder, but only one can be active at a time. Data from both systems will be logged. The motion system you have selected as active will be used in the real time displays. For each of these motion systems some basic parameters need to be set.

Attitude Sensor Ports: Choose which motion sensor you wish to set the parameters for. The motion system is not identified by name, but by the port it is connected to.

The following ports are available:

- COM2 (motion sensor 1)
- COM3 (motion sensor 2)
- UDP5 (attitude 1) Applies to EM 122, EM 302, EM 710, EM 2040 and EM2040C
- UDP6 (attitude 2) Applies to EM 122, EM 302, EM 710, EM 2040 and EM2040C

Roll reference plane: The roll reference plane is used to define the reference plane against which the roll angle is measured.

Select Horizontal or Pitch/Roll Plane:

- **Horizontal:** Select this alternative if roll is measured against the horizontal plane, i.e. against the plane normal to the gravity vector. This is the convention used by the Hippy 120, often emulated by other sensors.
- **Rotation:** Select this alternative if roll is measured against a plane defined as horizontal in the across-track direction, but following the vessel pitch in the along-track direction, i.e. as a rotation around the forward pointing axis of the vessel coordinate system. This is the convention usually used by inertial systems such as the POS/MV (the Tate-Bryant convention).

Attitude delay (msec): This parameter is used to define the expected time delay of the motion data.

If the data from the attitude sensor are delayed with respect to when they were valid, this may be corrected by the system provided the delay is known. This delay may be due to filtering and/or processing time in the sensor, and should be provided by its manufacturer. Some sensors are able to compensate for such delays by a prediction, but it is not advisable to use such a feature.

Active sensors parameter settings

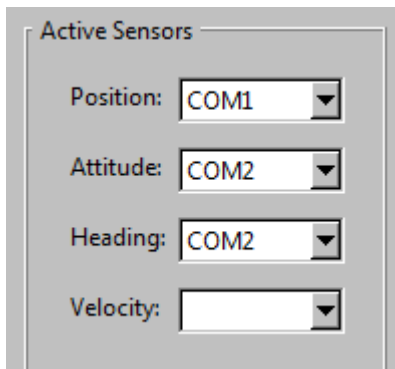

Only one positioning system, one motion sensor, one heading sensor and one velocity sensor can be active at a time.

The selection of which system/sensor to be active is performed by selecting which input port the relevant equipment is connected to. The available choices for each system/sensor is dependant on the settings made in the Input Setup configuration of the PU (Processing Unit).

Refer to *PU communication – Input setup* on page 275 for more information.

There is a drop-down combo box for each of the system/sensor types.

Note

When the Input Setup configuration is changed the Active Sensor setting must be checked.

Position: Select port number of active positioning system.

Motion: Select port number of active motion sensor.

Heading: Select port number of active heading sensor.

Velocity: Select port number of active velocity sensor.

Sensor setup – Location for EM 2040

Locations (of sensors) is located under the **Sensor Setup** tab on the **Installation parameters** display view.

Location offset (m)			
	Forward (X)	Starboard (Y)	Downward (Z)
Pos, COM1:	0.00	0.00	0.00
Pos, COM3:	0.00	0.00	0.00
Pos, COM4/UDP2:	0.00	0.00	0.00
TX Transducer:	0.00	0.00	0.00
RX Transd. port:	0.00	0.00	0.00
RX Transd. starb.:	0.00	0.00	0.00
Attitude 1, COM2:	0.00	0.00	0.00
Attitude 2, COM3:	0.00	0.00	0.00
Waterline:			0.00
Depth Sensor:	0.00	0.00	0.00

In order to make correct computations, SIS must know the physical location of all sensors, including it's transducers.

The locations must be referred to the vessel's reference point. The location of each system must therefore be given as a forward (x), downward (z) and starboard (y) position relative to the reference point. The coordinate system assumes that the x-axis follows the vessel's keel, and that the x-y plane is horizontal while the vessel is in normal trim.

Location parameters

Positioning systems (Pos): These settings are used to define the physical location of the selected positioning system's position point, i.e. the point on the ship where the position is valid.

Note

The position data you define here may however not necessarily be the physical location of the antenna. This is because settings in the positioning system's own software may redefine the location of the antenna. The xy values of the soundings are referred to the location of the active positioning system, and it is this virtual position that you must enter.

The downward locations are required if the bottom is being determined with respect to a vertical datum.

The downward position will also be used if the positions are to be corrected for vessel attitude. This requires that the actual physical antenna position is entered and that the given position is at the antenna.

TX/RX Transducer: Use these settings to define the physical location of the centre of the face of the respective transducer arrays.

Attitude (motion): The Attitude Sensor parameters allow you to define where the sensor is physically located, or where its data are valid, e.g. in case the attitude sensor is programmed to calculate heave at a different location than where it is actually mounted.

Waterline: Enter the vessel's waterline (in normal trim) related to the vessel's reference point. The value should be an average of two measurements; one on each side of the vessel. The measurement must be made at the same alongship location as the physical location of the motion sensor.

Note _____

If the vessel's displacement or trim changes during a survey, this value must be updated accordingly.

Depth sensor: Position of depth sensor.

Angular Offsets for EM 2040

Angular Offsets (of sensors) is located under the **Sensor Setup** tab on the **Installation parameters** display view.

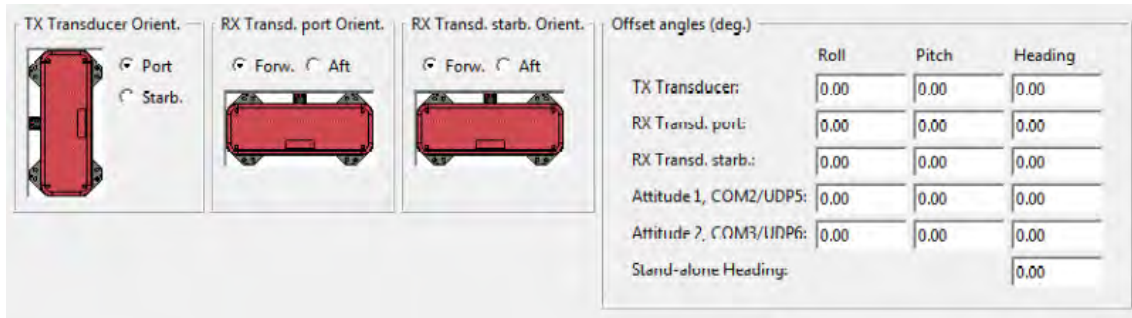

Note

*For a dual RX system the RX parameters are to be entered for **RX Transducer port** and **RX Transducer starboard**.*

In order to make correct measurements, the system must know the physical installation angles for the transducers and sensors relative the vessel coordinate system.

Offset angles are partly determined during installation and partly during calibration.

Angular offset parameters

Transducer orientation Use these settings to select the orientation of the TX and RX arrays. If the TX array is mounted with cables pointing to starboard side, select **Starb.** If the TX array is mounted with cables pointing to port side, select **Port**. If the RX array(s) is mounted with the cables pointing towards the stern, select **Aft**. If the RX array(s) is mounted with the cables pointing towards the bow, select **Fwd**.

TX Transducer/RX Transducer Use these settings to enter the installation angles. These settings are normally entered once and for all, but if the vessel undergoes repair or maintenance etc. and the array is moved, the installation measurements must be repeated and new angles defined.

Motion sensors (Attitude): Use these settings to set a correction offset for the corresponding values received from the motion sensors. The settings are added to the values received from the sensors.

Stand-alone Heading: Use this setting to set a correction offset from the values received from the heading sensor. It is only allowed to enter positive values. Example: If the offset is -0.15, you must enter 359.85.

ROV Specific for EM 2040

ROV Specific is located under the **Sensor Setup** tab on the **Installation parameters** display view.

This dialog box applies to depth determination from either depth or pressure sensors. If a pressure sensor is used, scaling and offset of the pressure sensor must be entered. **Scaling and Offset** parameters are located in **Runtime parameters**→**Sound Speed** frame, see *Sound speed for EM 2040* on page 305.

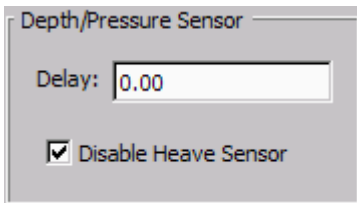

Depth/Pressure sensor parameters

The parameters are available only if ROV depth is selected in the *PU communication – Input setup* on page 275. Otherwise they are disabled. Also note that when deselecting the ROV depth selection in the Input Setup frame these parameters will be reset to default and disabled.

- **Delay:** This parameter is used to define the expected time delay (in ms) of the sensor data.
- **Disable Heave Sensor:** This must always be unchecked unless the effect of heave is taken into account by another sensor. An example is the depth of an ROV measured by a pressure sensor whose output also includes any heave effect unless the depth is large.

System parameters for EM 2040

System parameters is located on the **Installation parameters** display view.

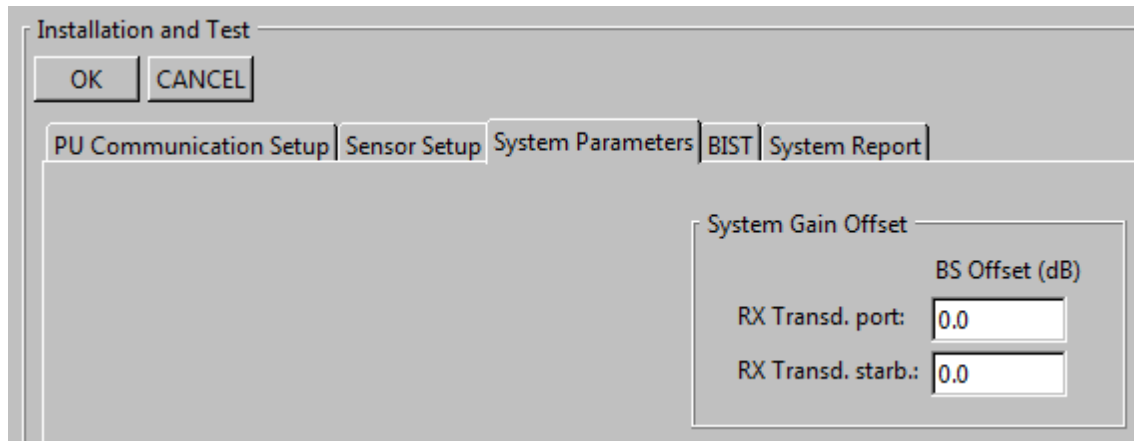

Note

*For a dual RX system the RX transducer BS offset are to be entered for **RX Transducer port** and **RX Transducer starboard**.*

Parameters

- **BS (Backscatter) Offset (dB) - RX Transducer:** The acoustic backscatter strength of the bottom is calibrated in our factory, and have a typical accuracy of ± 1 dB.

However, this value may be offset from zero to serve as a correction factor, for example if there is a change with the age of the system, or if data from two different systems are merged and there is a systematic offset between the two systems.

BIST – Built-In Self Test

The **BIST (Built-In Self Test)** options provide a number of automatic tests that may be started to check the operation of the echo sounder system.

Note

*The tests may be automatically run at echo sounder startup provided that this option is set to On from the **Tools**→**Custom**→**Set parameters**→**Startup options for the system** page.*

BIST is located on the **Installation parameters** display view.

Various test are available, and the test presented will depend on what system you have.

Parameters

- **Clear all:** Press to clear results of previous BIST tests.
- **Run all BISTs:** Press to run all available BIST tests.

Note

When the button is pressed, all BIST tests will be run, without any further questions.

- **BIST test buttons:** Single BIST tests can be run by pressing the corresponding test buttons.

The button turns green if the test results are OK, it turns yellow if the test is not successfully carried out. The button will turn red if the test fails.

Note

When a button is pressed, the selected BIST test will be run, without any further questions.

- **Save:** The results of the BIST tests may be saved to file. Press **Save** to set file name and storage location.
- **PU BIST Result area:** The results are presented in this area with the following information for each test:
 - Date: Date when the test was run.
 - Time: Time when the test was run.
 - Ser. No: Serial number of the transceiver unit.
 - BIST: The number of the BIST test that has been run.
 - Result: The overall result of the test.
 - Description: A description of the test returned from the PU (Processing Unit).

EM 2040 BIST

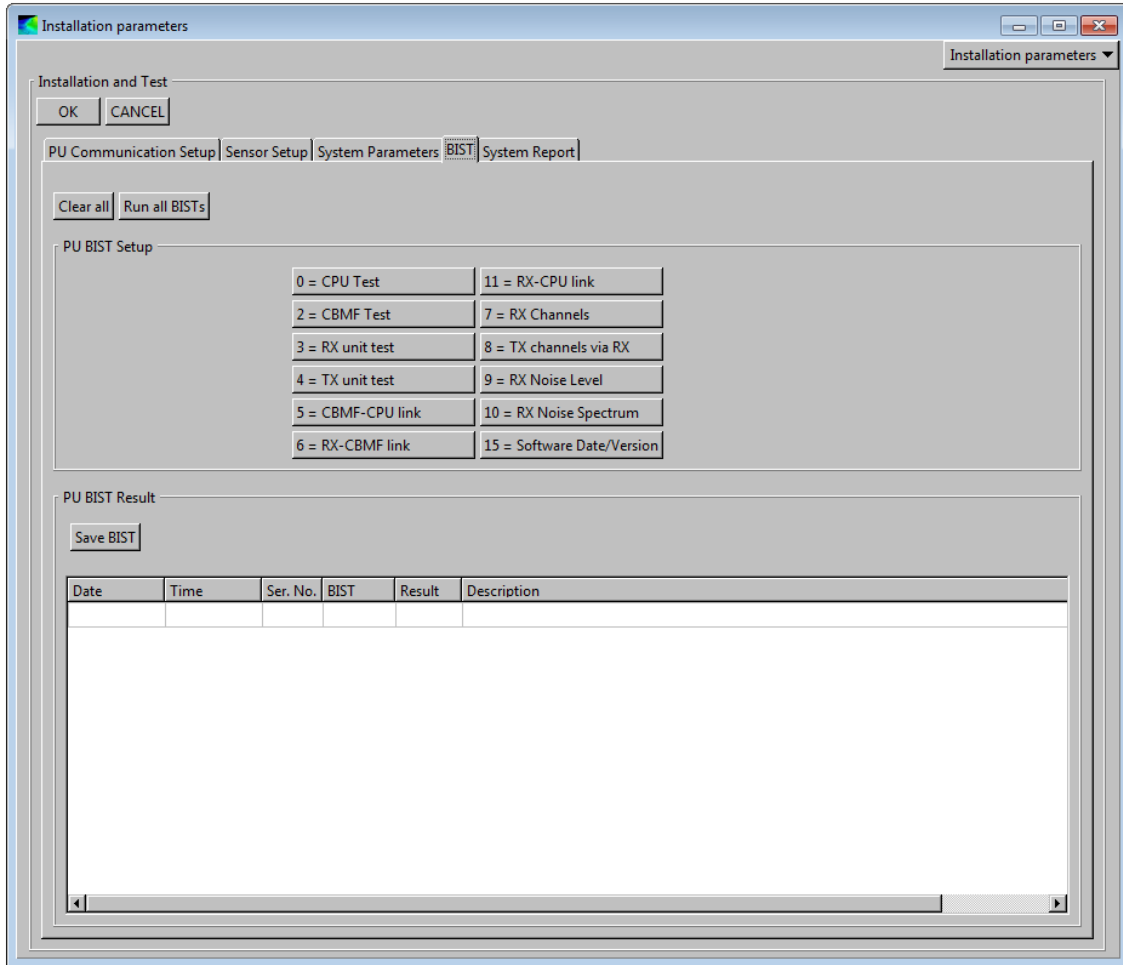

The following tests are available:

EM 2040 BIST

0	CPU Test
1	BSP Test
2	IO 2040 Test
3	RX unit test
4	TX unit test
5	IO 2040-BSP link
6	RX unit-BSP link
7	RX Channels
8	TX channels via RX
9	RX Noise Level
10	RX Noise Spectrum
15	Software Date/Version
16	System info

For description of the tests please refer to the Instruction Manual

System report

The **System Report** function will produce a status summary of all serial numbers and versions of the echo sounder. In addition a selection of tests (e.g. BISTs — Built In Self Tests and other tests) may be executed internally in the echo sounder and the results returned.

The result file name will be generated automatically by SIS and contains the echo sounder id and the date and time as part of the name. The file extension is .txt. This file name can not be changed by the operator.

The default location of the result is `...\\sisdata\\common\\bist`. The location of the result file might be changed by the operator.

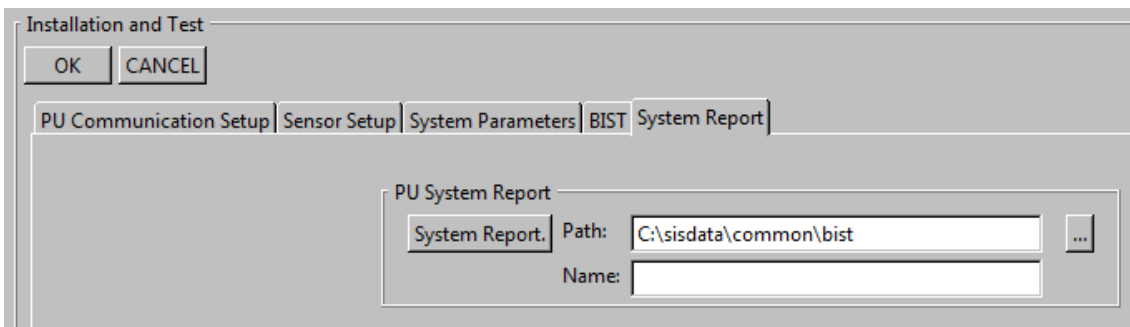

Parameters

- **Path:** Location of the result file. To change the directory, use the browse button [...] to find or make the relevant directory for storing the report.
- **Name:** Name of the result file will be shown. The file name can not be changed.

Runtime parameters

This section contains a description of the dialog boxes and parameter settings provided by the **Runtime parameters** frame in SIS

Note

*The **PU – Processing Unit** may be a separate hardware unit or an integrated part of the **TRU – Transceiver Unit** cabinet, depending on echo sounder system.*

For SIS it makes no difference whether the communication is with a PU or a PU inside a TRU. The term PU is used in this manual.

Topics

- *Sounder main for EM 2040 on page 297*
- *Sound speed for EM 2040 on page 305*
- *Filter and gains for EM 2040 on page 310*
- *Data cleaning on page 317*
- *GPS and delayed heave on page 323*
- *Simulator for EM 2040 on page 329*
- *Survey Information on page 332*

Related operational procedures

- *How to open the runtime parameter interface on page 134*
- *How to modify the runtime parameters on page 134*
- *How to collect the sound velocity profile on page 141*
- *How to convert your sound velocity profile to SIS format on page 143*
- *How to modify and load a sound speed profile into SIS on page 151*

Sounder main for EM 2040

Sounder Main is located on the **Runtime parameters** display view. The **Sounder Main** parameters allow you to:

- Define the pingmode, the desired swath coverage and the beam spacing
- Define maximum port and starboard coverage
- Define the maximum and minimum depth for the echo sounder
- Force a desired depth
- Select stabilization (pitch, yaw) and transmit control

Parameters – Sector coverage

	Port	Starboard
Max Angle (deg):	75	75
Max. Coverage (m):	500	500
Angular Coverage mode:	AUTO	
Sector Mode:	NORMAL	
Beam Spacing:	HD EQDST	

Port <-> Starboard: This button allows the settings for the port and starboard sector coverage parameters to be swapped. This is convenient when logging along a shoreline and the vessel is turning around.

Max angle (deg), port/starboard: These parameters allow you to define the maximum swath width by setting the maximum port and starboard angles. The values are entered in degrees.

Max coverage (m), port/starboard: These parameters allow you to define the maximum swath width to each side by selecting values in meters. The port and starboard angles (as defined above) will then be adjusted accordingly by the system. To make use of these settings, you must set **Angular Coverage mode** to Auto.

Angular Coverage mode: Choose between Manual and Auto.

- **Manual:** If Angular Coverage is set to manual, the values defined as Max port and starboard angle above (in degrees) are used directly. The Max coverage port and starboard settings (in meters) are not used in this case. Be aware that the outermost beams may be lost if the angular coverage set is larger than the coverage capability at the current depth.
- **Auto:** If Angular Coverage is set to Auto, the maximum coverage (in meters) and the maximum angles will set the swathwidth limit. The most limiting of the two criteria will be used. If the system is not able to fulfil the above, it will reduce the swath width further and as a consequence nearly all the beams will be valid. You may observe this in the **Numerical display**, as the numbers of beams accepted should almost equal to the number of beams available.

Sector Mode: This parameter controls the use of transmit sectors. The sector mode parameter may have one of the following values:

- **Normal:** All sectors are transmitted simultaneously.
- **Sngl port:** When single port mode is selected the starboard RX head is automatically turned off.
- **Sngl cent:** When single centre mode is selected only the centre sector is used.

- **Sngl stb:** When single starboard mode is selected the port RX head is automatically turned off.
-
- **Scanning:** One sector is transmitted per ping. This can reduce multipath problems in areas with soft sediments together with strong reflectors. The negative effect is a reduced ping rate.

Single sector and **Scanning** modes may use shorter pulse length to increase resolution.

When using the **Port < - > Starboard:** swap button, both for single and dual head configurations, the sector mode port and starboard selections are also swapped automatically.

Note

You must manually turn on the affected head when returning to SNGL CENT, NORMAL or SCANNING selections.

Beam spacing: Depending on the purpose of the survey, you may define the distribution of the beams on the seafloor.

- **Equidistant:** This setting gives a uniform distribution of soundings on the seafloor, and it is the normal mode for a bathymetric survey.
- **Equiangle:** The beams are distributed with an equal angular spacing based on the angular coverage used. This gives many soundings close to the centre of the survey line, and few on the edge of the swath.
- **High density Equidistant:** In this mode the number of soundings are increased. This is achieved by directing some of the beams closer to the centre of the survey line and performing several soundings per beam on the edge of the swath. This results in an equidistant distribution of the soundings.

Parameters – Depth settings

The screenshot shows a 'Depth Settings' dialog box with the following controls:

- Force Depth (m):** Text input field containing '1'.
- Min. Depth (m):** Text input field containing '1.00'.
- Max. Depth (m):** Text input field containing '150.00'.
- Dual swath mode:** Dropdown menu set to 'OFF'.
- Ping Mode:** Dropdown menu set to '300kHz'.
- Pulse Type:** Dropdown menu set to 'AUTO'.
- FM disable:** An unchecked checkbox.
- Detector Mode:** Dropdown menu set to 'NORMAL'.

Force depth (m): If there is a lot of acoustic interference or if the water is very aerated, the echo sounder may not find the correct depths. In order to help, you can then enter the approximate depth. This depth may be taken from your navigational charts, or from a navigation sounder elsewhere on the vessel. Forcing the depth will cause the system to set its gain and range windows accordingly, and ignore its own findings about where the bottom is.

There is a short-cut to forcing the depth. In the Water column display you may select the forced depth simply by holding down the **Ctrl** button while clicking at the selected depth using **right mouse** button. This assumes that **Force depth** has been enabled in the **Water column**→**Show/Hide** menu. See *Water column – Show/Hide* on page 243.

Min./Max. depth (m): These parameters define the operational depth range. This range should normally be wide enough to cover all depths encountered during the survey, as only depths within this range will be accepted by the system.

A narrow range will help the system in bottom tracking under difficult conditions. In some cases it may be necessary to temporarily narrow the range to assist the system in bottom tracking. However, you must then monitor the actual depth closely, and adjust the depth window as often as required.

Note _____

It is very important that valid depths are entered here when the echo sounder starts “pinging”. If the bottom depth exceeds the limits with more than 10%, the sounder will not lock. It may therefore be useful to enter larger values in the beginning to accept a more dynamic depth, even though this may slow down the initial bottom detection when the system is started.

If the bottom depth exceeds the limits given here it will simply loose track. The true depth should therefore be monitored and compared with the settings during the survey.

- **Minimum depth (m):** Set the minimum limit of the depth range.
- **Maximum depth (m):** Set the maximum limit of the depth range.

Dual swath mode: Using dual swath implies that two fans are transmitted, one in front of the other. The intention is to obtain a better coverage of the seafloor, for example when the highest pingrate is already used and without decreasing vessel speed. The following settings are available:

- **OFF:** Dual swath is disabled (i.e. standard single swath).
- **FIXED** The alongship angle between the two transmit fans is equal to the alongship opening angle of each fan.
- **DYNAMIC** The alongship angle between the two transmit fans is determined based on vessel speed, ping rate and depth in order to provide uniform alongship sampling of the seafloor.

Note _____

Some modes or pulse lengths may not allow for dual swath.

Ping mode: This parameter defines the operational frequency of the multibeam echo sounder. Depending on your application you can select frequencies:

- 200 kHz – for deeper waters
- 300 kHz– for normal operation
- 400 kHz – for very high resolution inspection
- 300 kHz: Three transmit sectors are used per swath. Different frequencies are used to separate the sectors. With short pulse length each sector needs a large bandwidth. This means that frequencies used may be e.g. 260, 290 and 320 kHz. With long pulses a reduced band width is required. To extend the coverage, low frequencies are selected, like 270, 275 and 280 kHz. For each mode and pulse length the system is tailored for optimum use of the bandwidth.
- 200 kHz: At 200 kHz the transmit sectors are wider, so only two sectors are needed per swath. Compared to 300 kHz mode the maximum range is increased caused by lower attenuation in the water, whilst the beam widths are increased by a factor of 1.5.
- 400 kHz: Due to the high frequency the beam opening angles becomes narrower, and the range coverage is decreased, compared to 300 kHz. Shorter transmit pulses are used. This requires correspondingly higher bandwidth and gives increased resolution.

Pulse type: The pulse can be set to be of the following types:

- *Auto*: When selected the system will automatically use a pulse length according to current depth
- *Short CW*: Shortest CW (Continuous Wave) pulse length for set frequency
- *Medium CW*: Medium CW (Continuous Wave) pulse length for set frequency
- *Long CW*: Longest CW (Continuous Wave) pulse length for set frequency
- *FM*: Frequency modulated pulses for deeper waters

Table 2 Pulse lengths

	200 kHz		300 kHz		400 kHz	
	CW	FM	CW	FM	CW	FM
Normal mode	70/200/600 μ s	3/12 ms	70/200/600 μ s	2/6 ms	50/100/200 μ s	N/A
Single sector mode	35/70/150 μ s	1.5 ms	35/70/150 μ s	1.5 ms	25/50/100 μ s	N/A

FM disable: This control button can be used to turn off the use of FM pulses. It is recommended to keep this button unchecked. The FM pulses are used to extend the detection range capability without losing range resolution. For the 400 kHz mode the **FM disable** control has no effect.

Note

FM mode requires a 3D velocity input to compensate for a range shift caused by the Doppler effect.

Detector mode: Select detector mode to optimize the systems ability to recognize the bottom, wreck, structures, etc., depending on water condition. Select from:

- *Normal*: The normal bottom detection mode

- *Waterway*: Suitable for shallow channels and rivers
- *Tracking*: A general shallow water mode for tracking of targets and sudden depth changes
- *Minimum depth*: Designed for detecting wrecks etc.

The *Waterway*, *Tracking* and *Minimum depth* modes are mainly intended for use in shallow waters. In shallow waters special TVG may improve the performance. A tracking routine is used instead of the ping-ping filter. This means that the bottom tracking does not depend that much on the previous pings and will easier track sudden depth changes. Range gate, based on previous pings, still limits the search.

Note

Surveying on vertical objects should be done with a wide coverage setting. For the Waterway, Tracking and Minimum depth modes it is important that the normal incidence is within the receiver fan. Use at least 90 degrees coverage along pier walls to ensure that strong normal incidence from the pier is detected.

Normal mode is based on the standard detector, but with improved multipath rejection. A ping-ping filter is used to guide the bottom tracking. If there is a problem with aeration, Normal mode is recommended. The ping-ping filter will then help the detector to keep track of the bottom.

Parameters – Transmit control

The screenshot shows a 'Transmit Control' panel with the following settings:

- Pitch stabilization
- Along Direction (deg.):
- Yaw Stabilization:
 - Mode:
 - Heading:
 - Heading filter:
- Max. Ping Freq. (Hz):
- Min. Swath Dist. (m):
- External Trigger
- 3D Scanning:
 - Enable scanning
 - Min. (deg.):
 - Max. (deg.):
 - Step (deg.):

The maximum electronic tilt is limited to ± 10 degrees. The ship's attitude and the applied transmitter tilt is always used to calculate the x, y and z parameters for each bottom detection. This assures that the x, y and z values are correctly calculated, even if more tilting was needed to do a full pitch and yaw stabilization.

Pitch stabilization: At open sea, the swath area on the bottom will move back and forth following the vessel pitch. This will lead to loss of sampling regularity, and thus also limit the vessel speed at which 100% bottom coverage is possible. To account for this effect the system's transmit angle may be set to vary with the pitch in order to stabilize the direction of the emitted vertical transmit fan. This option should thus normally be ON.

Along Direction: This function can be used to tilt the transmit sector forward and backwards. This can be used to avoid a too strong echo at the normal incidence.

Yaw stabilization: The yaw stabilization creates even alongship sounding spacings when the vessel's course is variable. The parameter is implemented with variable tilt angles on the individual transmitter beams. Yaw stabilization is only possible with Dual Head installations. With Dual Head the two transmit sectors are steered individually. The echo sounder operates most efficiently when the transmission angle is as close to 0 degrees as possible relative to the vessel's heading.

Figure 20 External forces acting on a vessel

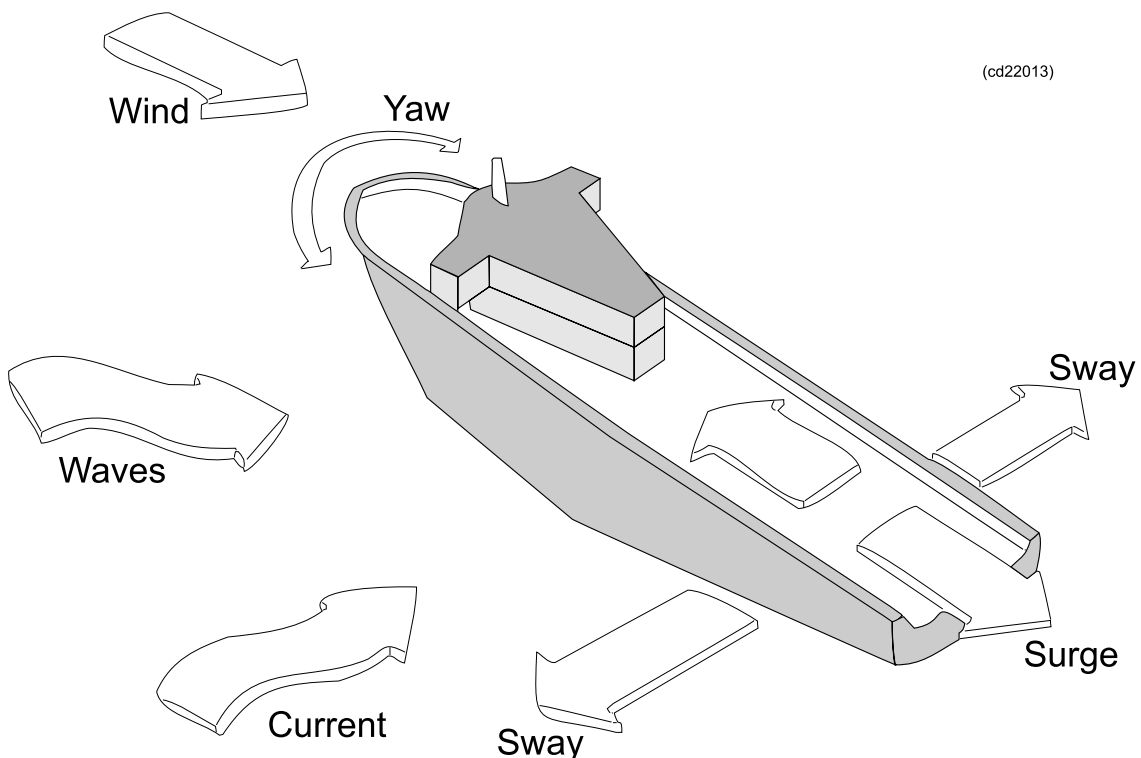

Mode: Three stabilization modes are available.

- *Off*: No heading stabilization takes place. The transmitter sector follows the current heading of the vessel. Unless the vessel's heading is 100% straight you may experience blind zones on the survey coverage when you operate in deeper waters (exceeding 300 to 500 meters).
- *Manual*: The transmit fan is placed perpendicular to a manually selected course. This course is selected with the Yaw Compensation parameter described above. The setting should only be used on long and straight survey lines, but it is also useful if you need to compensate for a crab angle caused by current or wind.
- *Rel. mean heading*: This setting places the transmitter sector perpendicular to a filtered course corresponding to the vessel's current mean heading. The course input is then taken from the gyro, and filtered with the **Heading Filter** parameter described below.

Rel. mean heading is the recommended yaw stabilization mode. With this setting the average yaw steering will be close to zero, avoiding an offset caused by e.g. a crab angle. (Also the operator does not have to remember to set the course line.)

Heading: Allows you to enter the vessel's heading manually.

Heading filter: This parameter specifies the level of filtering of the heading

Applying this filter will even out minor course adjustments due to wind, sea or current. The filter strength required depends upon the vessel properties, and how well the vessel is steered.

The heading filter controls how fast the filtered heading used during logging will follow the actual heading of the vessel.

Max. Ping Freq (Hz): The ping rate is normally limited by the acquisition time (two way travel time) of the receive data plus a little overhead. Dual swath can be enabled to increase the alongship sampling rate. With the **Max. ping freq** setting is possible to limit the maximum ping rate. This can be used to lower the amount of logged data, for example when running at slow speed, or if 100% alongship coverage is not required.

Typical data rate (Mbyte/hour) per swath for one RX transducer:

Depth below transducer	Bathymetry	Seabed image	Water column	Velocity	Mode
10 m	850	350	5500	43	Very shallow
45 m	225	165	3200	43	Shallow
200 m	100	50	1700	43	Deep (FM)

Minimum Swath Distance

Min. Swath Dist. (m): You can set a minimum swath distance, i.e. a minimum distance between consecutive “footprints” on the sea floor or river bottom in the direction of the moving vessel.

The aim of this function is to ensure that a survey will contain logged data with a minimum and constant data density. To obtain the required data density the PU will adjust the ping frequency depending on the measured depth and the vessel speed. Dual swath capability, available for some echo sounders, will also be taken into consideration.

The default value is 0, indicating not used. The legal range is 0.1 — 1000.0 meter. The resolution is 0.1 meter.

When the **Min. Swath Dist. (m)** has been set the actual achieved swath distance is registered and displayed in the **Numerical Display** frame in the **Swath Dist.** item. The displayed format is Required dist./Achieved dist. in meters.

A warning will be issued by default if the required data density can not be obtained. A second warning can be issued if the data density is too high, this warning is disabled by default. Configuration of these warnings is made in the **Tools** → **Custom...** → **Set Parameters** → **Logging** menu.

External trigger

External Trigger: When selected, an external trigger signal causes the echo sounder to send a ping. The Pinging on/off function must be on.

3D Scanning

This function allows the transmitter to be steered back and forth in the alongship direction.

Enable scanning: Enables and disables the 3D Scanning function.

Min. (deg): The Min. (deg.) parameters sets the minimum scan angel relative to the TX array.

Max. (deg): Max. (deg.) parameters sets the maximum scan angel relative to the TX array.

Step. (deg): The Step (deg.) parameter sets step size. A step size of 0.0 stops the scanning even if the **Enable scanning** selection is set.

When scanning is active a manually set Along Direction (deg.) and the Yaw Stabilization settings are neglected (see both parameters in the picture above).

Note

*Note that the **Special mode** functionality will affect the **3D Scanning** operation: selection of **Passive mode** will disable **3D Scanning**.*

Sound speed for EM 2040

Sound Speed is located on the **Runtime parameters** display view.

The accuracy of the depth data obtained from the system depends on the use of a correct sound speed profile. You must ascertain that the applied profile always corresponds to the real conditions. On the average, errors in the sound speed profile is recommended to be kept below 0.5 m/s.

Parameters – Sound Speed Profile

The screenshot shows a dialog box titled "Sound Speed Profile". It has three rows of controls:

- The first row has a button labeled "Use Sound Speed Profile" followed by a text box containing "default.asvp" and a small square button with three dots (the browse button).
- The second row has a label "Abs. coeff. files, salinity" followed by a text box containing "C:\sisdata\common\svp_abscoeff\default".
- The third row has a label "Abs. coeff. files, CTD" followed by a text box containing "C:\sisdata\common\svp_abscoeff\default".

Use Sound Speed Profile: The Sound Speed Profile parameter allows you to select the sound speed profile file to be used in the echo sounder’s depth calculations.

If you want to change to a different profile, click the **browse** button on the right-hand side (button with three dots). When the correct profile is selected, press **Use Sound Speed Profile**.

A standard sound speed profile file has the extension `.asvp`, but other formats with other extensions are also supported. When a file is selected, an `.asvp` file will always be generated if necessary. The ROV file format has the extension `.actd`. This file format also contains a density profile necessary for automatic calculation of a “Scaling” factor.

If you manually select a sound velocity profile, or a profile is received for instant use (i.e. S0x datagrams), SIS will check if the number of entry points in the profile satisfies the criteria defined in the **Sound speed profile format**.

Note

If the profile is too big according to given criteria, a warning will be issued and the profile will not be used.

If SIS is running several sounders, the maximum number of allowed entry points is set according to the most restrictive echo sounder in use.

If the intended profile is too long, it must be thinned manually before use.

The used sound speed profiles (`.asvp` files) and the associated absorption coefficient profiles (`.abs` files) are stored with the raw data files on the same directory. The files are stored when the **Use Sound Speed Profile** button is pressed and the files will be named using the current date and time preceding the original `.asvp` and `.abs` file names. The file name `20110920_113610_ProfileName.asvp` tells that the file `ProfileName.asvp` was selected for use 20th of Sept. 2011 at 11 hours 36 min. and 10 sec. The used profiles will be available for post processing purposes.

Absorption coefficient files: When selecting a new sound speed profile, this will affect the absorption coefficient settings in the system. Each sound speed profile is associated with sets of absorption coefficient files, either based on salinity input or based on CTD input. The files may already exist, or they may be created at the moment new input of salinity or CTD information is given. Salinity is input in the **Filter and Gains** tab in the **Runtime parameters** frame.

New input of CTD based absorption coefficients will normally be given through the SOX datagrams. Input of salinity or CTD will create new directories for the Absorption coefficient files. The paths are shown in the **Sound Speed** tab as

- Abs. coeff. files, salinity
- Abs. coeff. files, CTD

Note

A user provided sound velocity profile (with a user defined name) does not normally have a set of associated absorption coefficient files initially. The files will therefore be generated automatically based on the current salinity value. The name of the files will contain salinity as a part of the file name, and this will show up in the salinity text field. In this case the Sound Speed Profile text field will show the original user selection.

If a datagram of format S00, S01, S02, S03, S04, S05, S06 or S07 is received this implies that the data should be used immediately. The Absorption coefficient files field are updated automatically. The Use Sound Speed Profile text field will be updated with the name of the new sound velocity profile. In the case of a S00 datagram it will contain salinity as part of the name.

Parameters – Sound Speed at Transducer

The screenshot shows a control panel titled "Sound Speed at Transducer". It contains four input fields:

- Source:** A dropdown menu currently showing "PROFILE".
- Sound Speed (m/sec.):** A text box containing the value "1500.0".
- Sensor Offset (m/sec.):** A text box containing the value "0.0".
- Filter (sec.):** A text box containing the value "60".

When the sound speed in the surface area is rapidly changing with time and position, it is recommended to install a sound speed sensor close to the transducer face. This particularly applies to installations with tilted sonar head(s).

The sound speed at the transducer depth is used by the beamformer when calculating the beamformer coefficients. The same sound speed is also used as a starting point in the ray bending corrections. If a sound speed error is present only for a thin layer at the transducer depth, the ray bending, using Snell's law, will correct for the error made by the beamformer as long as the array is horizontal. But if the array has a roll angle, there will be an angular error that increases with the beam steering angle and the roll angle.

If the sound speed value at the transducer derived from the sound speed profile deviates too much from the probe or manual values this will be indicated in the Numerical display (Tr. svp and Tr. sensor).

Source: Select the source for the Sound Speed at Transducer. Choose between Manual, Profile and Sensor/Probe.

- **Sensor:** The system will use a filtered sound speed value derived from the sound speed sensor at the transducer. The filter is configured as described below. This option will only be available if the sound velocity probe is used

Note

Please note that the sensor must be enabled from the External Sensor setup.

- **Manual:** The echo sounder system will use the sound speed you define.

Caution

The manual setting is intended for experienced operators only!

- **Profile:** The system will use the sound speed profile to derive the sound speed near the transducer/sonar head. If no matching depth is found in the profile, an interpolated value is used.

Sound Speed (m/s): Set the sound speed at transducer directly to a fixed value. This function is only available if **Manual** is selected.

Sensor Offset (m/s): This parameter is used to set a correction offset if Source is set to **Sensor**. The offset will be added to the used sound speed values.

Note

*When a new profile is taken into use, always set the offset so that the sensor value is the same as that in the profile at the transducer depth. This is most easily done using the values from **Numerical display**.*

Filter(s): The length of the filtering of the sound speed sensor data can be selected. This also sets the update rate i.e. how often a new sound speed value derived from the filter is set. The filter is a median filter. Values outside 1300 to 1800 m/s are removed before the filter is run.

Parameters – Depth/Pressure Sensor

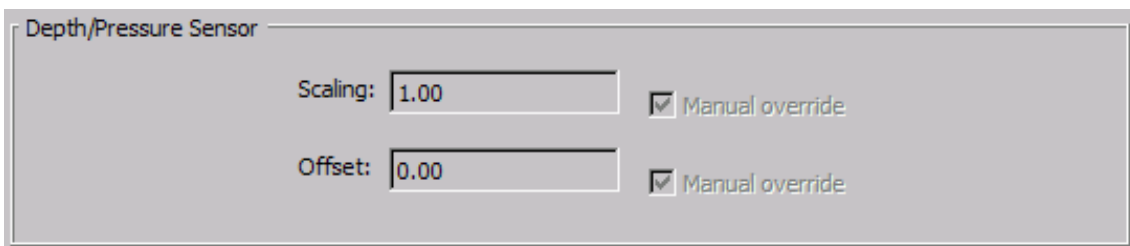

Depth/Pressure Sensor

Scaling: Manual override

Offset: Manual override

Scaling and Offset: The Scaling and Offset parameters are used for ROV operation and can be changed at any time during pinging and logging operations.

In addition to setting the parameters manually, these parameters may also be set automatically:

- 1 SIS can receive Offset data (i.e. barometer) from an external source, via a serial line, to the HWS. This input is converted from an external user defined format to an internal format used by SIS. The conversion is currently performed by a separate process which may easily be changed if the input format is changed. The resulting input information is displayed in the Offset field.

- 2 The Scaling may be automatically calculated based on an `.actd` file and the current ROV depth and position. The result is displayed in the Scaling field.

Manual override: The automatic updates may be enabled/disabled by a **Manual override** button for each parameter. These buttons may be operated independently. The PU is updated with the Scaling and Offset parameters (whether set manually or automatically) only when they are changed and with a minimum of 3 sec. intervals.

When mode is automatic the corresponding field (Scaling and/or Offset) is updated with new calculated (Scaling) or received (Offset) values. When in manual mode, the value set by the operator is displayed.

Note

*The calculation of **Scaling** is only performed as long as an `.actd` file is selected in the **Sound Speed Profile** field in the **Sound Speed Profile** group. That is if a standard `.asvp` file, or any other file format, is selected, the calculation stops (as the necessary density information will be missing).*

Note

*The **Scaling** and **Offset** parameters are only enabled as long as **ROV depth** input has been selected on an input port in the **Installation Parameters** frame.*

*Reminder: **ROV** input selection must be confirmed using the **OK** button. When the **ROV, depth** selection in the **Installation parameters** is turned off, the **Scaling** and **Offset** settings are reset.*

Before the barometer input can be received it is necessary to prepare the system by setting the input serial port:

- 1 Stop pinging.
- 2 Select **Tools**→**External Sensors** from the Main menu bar.
- 3 Enable **Barometer** from the displayed window.
- 4 Select the relevant input port
- 5 Press **OK**.

The barometer input will be received by SIS on the selected port. See Numerical display – Barometer item.

Related topics

- *Numerical display* on page 68
- *Filter and gains for EM 2040* on page 310
- *External sensors* on page 371
- *PU communication – Input setup* on page 275
- *Sound speed profile formats* on page 544
- *Implementation of absorption coefficients* on page 504
- *Handling of SSP datagrams* on page 539

Filter and gains for EM 2040

Filter and Gains is located on the **Runtime parameters** display view.

Parameters – Filtering

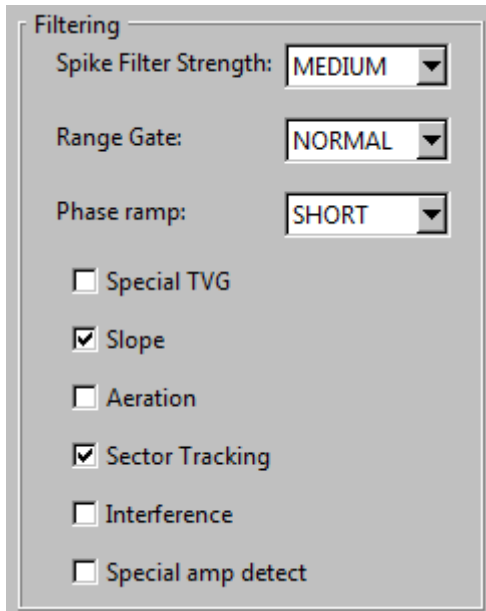

The screenshot shows a 'Filtering' dialog box with the following settings:

- Spike Filter Strength: MEDIUM
- Range Gate: NORMAL
- Phase ramp: SHORT
- Special TVG:
- Slope:
- Aeration:
- Sector Tracking:
- Interference:
- Special amp detect:

There is always a small risk of false detections in a multibeam echo sounder. This is due to external factors such as fish shoals, acoustical interference from other systems, passing over vessel wakes, etc. According to bottom conditions, you can apply the included filters to assist the system in discriminating against erroneous measurements. It is recommended to use different filter settings than those recommended only if the occurrence of false detections is higher than expected.

The recommended settings are:

- **Spike Filter Strength:** Medium
- **Range gate:** Normal
- **Phase ramp:** Normal
- **Special TVG:** Off
- **Slope:** On
- **Aeration:** Off
- **Sector tracking:** Off
- **Interference:** Off
- **Special amp detect:** Off

Spike Filter Strength: Choose between *OFF*, *WEAK*, *MEDIUM* and *STRONG*.

This is used to define to what degree a non-smooth bottom is to be accepted. The filter remove beams with depths that deviate too much from a smoothed bottom profile as derived from the detected beams. The stronger filtering, the less deviation is accepted.

If you select OFF, no filtering will take place.

For detection of objects in the water column, like free spans on a pipe line, it may be better to reduce the spike filter strength.

Range Gate: Choose between *SMALL*, *NORMAL* and *LARGE*.

When the system detects the bottom, it will perform the search within a predefined depth window, where the depth limits are based on the information from the previous pings. The range gate setting is used to determine the size of this window.

If the depth varies considerably alongtrack it may be useful to select a large range gate, but this may also increase the chance for false echoes from side lobes, interference or other noise sources.

Selecting a large range gate may reduce the ping rate slightly.

Phase ramp: Choose between *SHORT*, *NORMAL* and *LONG*.

This parameter is used to specify the amount of range overlap between the detections.

When set to *SHORT*, the number of samples used for phase detection will be equal to the range distance between the beam and it's neighbours. As a result, there will be no averaging of phase detections between beams. (Note that this is provided that a minimum number of phase samples are available to do proper phase detection.)

When set to *NORMAL*, the number of samples used for phase detection will normally be equal to twice the range distance between the beam and it's neighbours. As a result, there will be a slight averaging of phase detections between beams.

When set to *LONG*, a fixed portion of the phase curve, corresponding to ± 40 degrees phase angle, is used for the phase detection. This will result in an increasing averaging of phase detections between beams with increasing beam angle.

SHORT phase ramp gives the best resolution, but a side effect can be that the detected bottom will have increased noise. Recommended setting is *NORMAL*.

In the bottom detector a Time Varying Gain is applied. Enabling the Special TVG option in the **Filter and Gains** menu will normally reduce problems with multipath at shallow water.

Note

Remember to turn Special TVG off when going to deeper water, if not, coverage will be reduced caused by to little gain.

Slope: With this filter enabled, the system checks for bottom slopes that tilt inwards. These slant towards the vessel, and they are removed because the filter requires that the athwartships distance increases for every beam from the centre. Such detections are normally false, and after removal a new bottom detection is performed searching for a value with increased range

The slope filter should normally be enabled.

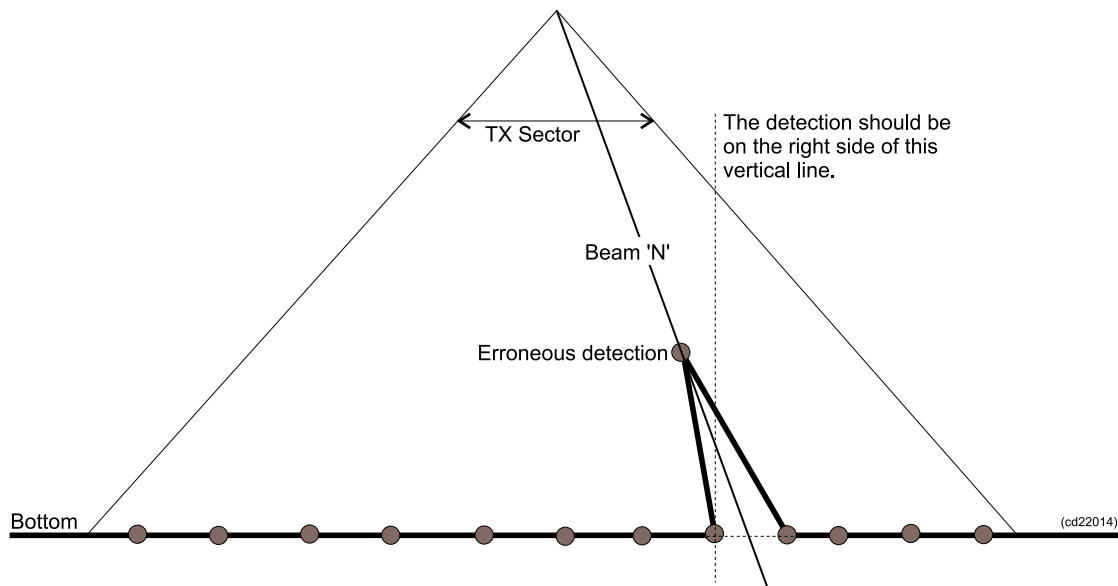

Aeration: If the transducer installation suffers from air bubbles close to the transducer, the system may have problems with bottom tracking. Activating this filter will force the system to keep tracking the same depth for a longer period. If you have aeration problems in areas with relatively constant depths, this filter will increase the performance of the system. However, if the bottom depth varies considerably, the filter may have an adverse effect.

Sector tracking: The transmitter operates with several pulses within each ping. Each pulse covers different sectors of the total swath. This setting will turn on an automatic gain compensation to avoid amplitude offsets between these sectors. During normal operations, the Sector Tracking should be on. However, if the survey specifications demand a fully calibrated system for sidescan image, this function should be turned off. This setting does not affect the depth measurements, only the backscatter strengths.

Interference: If the vessel is equipped with other echo sounders or sonars operating on frequencies close to the echo sounder, you may experience interference. The best solution is to synchronize the operation of the different systems. If synchronization is not possible, this filter may reduce interference problems.

Special amp detect: This button enables an alternative detection mode for beams close to the normal incidence. This detector mode can reduce noise spikes in the data on some bottom types.

Parameters – Absorption coefficient

The absorption coefficient depends upon depth, water temperature, salinity and frequency. A correct value is important with respect to the validity of the bottom backscatter data measured by the system.

The absorption coefficient as a function of the depth must therefore be calculated for the frequencies used by the echo sounder.

Source: There are three alternatives:

- **Salinity** – absorption coefficient based on salinity input.

If the source is set to salinity, the average absorption coefficient is calculated using the current sound profile (to find the temperature profile), the depth based on the previous pings and the specified average salinity. The average absorption coefficient will then be calculated by SIS for the relevant frequency and it will be updated and displayed with changing depths. If the salinity in the water is constant, this is the recommended setting.

- **CTD Profile** – absorption coefficient based on profile input.

The absorption coefficient can be calculated from a sound speed profile that includes information necessary to calculate an absorption profile.

The sound speed input datagram (SSP) must be used. When using a CTD profile from an SSP datagram, the absorption coefficient profile will automatically be calculated by SIS for the required frequencies.

It is also possible to specify the absorption coefficient directly in the SSP datagram, but then one datagram must be made for each frequency used by the echo sounders (i.e. the full range of 12, 31.5, 60, 70, 80, 90, 95, 100, 200, 250, 300, 350 and 400 kHz), and the frequency must be specified in each datagram. These datagrams must have the same acquisition date and time and must be sent with no more than 10 seconds interval.

Using this CTD Profile option, which will increase the accuracy of the bottom reflectivity data; SIS will calculate the average absorption coefficient through the

water column. The absorption coefficient values displayed will change continuously depending upon the depth.

- **Manual** – manually selected absorption coefficient

It is possible to manually specify the absorption coefficient for the relevant frequency. This must be the average absorption coefficient for the water column.

Salinity (parts per thousand): If the source is set to Salinity, the average salinity can be entered in this field.

200.0 / 250.0 / 300.0 / 350.0 / 400.0 kHz: If the source is set to Manual, the manual or calculated absorption coefficient for each frequency from 200.0 to 400.0 kHz (in steps of 50 kHz) can be entered in these fields.

If the source is set to Salinity or CTD, the frequency field is disabled (greyed), but it will show the current value of the absorption coefficient (dB/km) used for the frequency.

Parameters – Normal incident sector

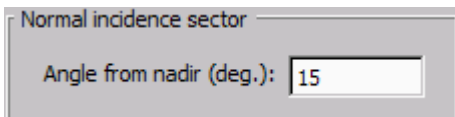

Angle from nadir [deg.]: This value is used to define the angle at which the bottom backscatter can be assumed not to be affected by the strong increase at normal incidence. The optimum crossover angle will vary with the bottom type.

For seabed imaging, it is important to adjust this angle so that a minimum of angle dependent amplitude variation is seen. This is to give best use of its dynamic range. The bottom backscatter strengths in the ping display are not affected by this setting.

Parameters – TX Power

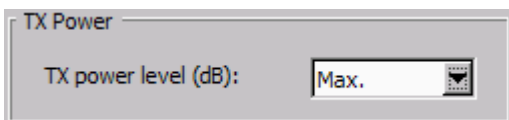

TX power level (dB): TX power can be lowered 10 or 20 dB to avoid saturation in shallow water.

The echo sounder will automatically reduce power level at shallow depths. You may reduce the maximum power level by this setting. Recommended setting is Max. Using -10 or -20 dB the max coverage will be limited.

Parameters – Water Column

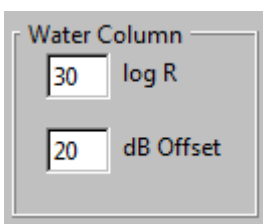

Water Column Time Varied Gain (TVG) function.

In active mode the applied TVG function is $X \log R + 2 \alpha R + C$. The X and C parameters can be set by the operator. The log function can be set from $10 \log R$ up to $40 \log R$. The default value is 30. In the water column datagram the amplitude is represented by 8 bits (to save storage space) with 0.5 dB resolution. The dynamic range is -64 to +63.5 dB, well suited for normal bottom echoes. But echoes in the water column can be weaker than -64 dB. To be able to record these echoes, an offset, C, can be added. This offset is as default set to 20 dB. This means that the dynamic range is changed to -84 to +43.5 dB.

The parameters are stored in the water column datagram. SIS corrects for the offset (C), so the echo level in the display will remain unchanged when C is changed. To utilize the increased dynamics, the water column color pallet (default -50 to 0 dB) must be adjusted, for example to -70 to 0 dB.

log R: X, range is 10 – 40, default is 30.

dB Offset: Offset, range is 0 – 40, default is 20 dB.

Parameters – Special Mode

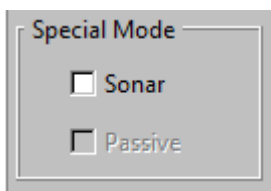

Sonar mode is a special mode intended for inspection purposes. The main output is the water column. The multibeam sounder will act like a sonar with manually selectable acquisition range and sector coverage. The bottom detector will still be active, but is not used to automatically select sector width and range.

Sonar mode is controlled by using existing parameters in the **Runtime** → **Sounder Main** menu:

- The sonar range is selected using the **Depth setting** → **Max. Depth (m)** parameter
- The sector width(s) is selected by using the **Sector Coverage** → **Max Angle port and starboard** parameters

The WC display will, like a sonar, show the same range for all beams. The TX pulselength and modes can be selected as in standard mode. If auto pulse mode is selected, the pulselength is adjusted dependent on the operator set sonar range (Max Depth parameter).

In sonar mode it is possible to select passive mode (this turns off the transmit pulse). The water column TVG is then turned off. The echo level shown is the spectral isotropic noise level. This means that receive transducer sensitivity, receive beam directivity and receive bandwidth is compensated for ($NL = EL - M + DI - 10 \log BW$). To be able to keep the same colour scale in the water column display as in active mode (used for BS), an offset of 100 dB is subtracted (45 dB noise level will then be displayed as -55 dB). Frequencies and RX bandwidth are used as in active mode. The RX beam patterns are corrected for. The “display gain” can be selected in the SIS water column window

as usual (Default = -50 to 0 dB). In passive mode the bottom detector is disabled. This mode can for example be used to search for noise and interference sources (direction and frequency). The ships flow noise and propeller noise can be checked.

The **Special Mode** selection status will be displayed in the main SIS display bar.

Sonar: This control button is used to turn **Sonar** mode on and off.

Passive: This control button is used to turn the **Passive** option on and off. The **Passive** option is disabled when **Sonar** mode is off.

Note

*Selecting **Passive** mode will disable 3D Scanning.*

Data cleaning

The **Data Cleaning** tab is located under the **Runtime parameters** display view.

The RTDC (Real Time Data Cleaning), uses rules to process the echo sounder data. A rule is a set of parameters that controls the algorithms used in the processing.

Seabed image processing in the Grid Engine may also be set up from the **Data Cleaning** frame

Note

The Real Time Data Cleaning module does not delete any depths, but flags depths that are invalid according to the rules. You have full control of this processing at all times.

The data cleaning interface is organized in a basic setup display and an advanced setup display.

Selecting predefined data cleaning levels

The basic setup allow you to choose the data cleaning level by a simple selection from a range of predefined levels.

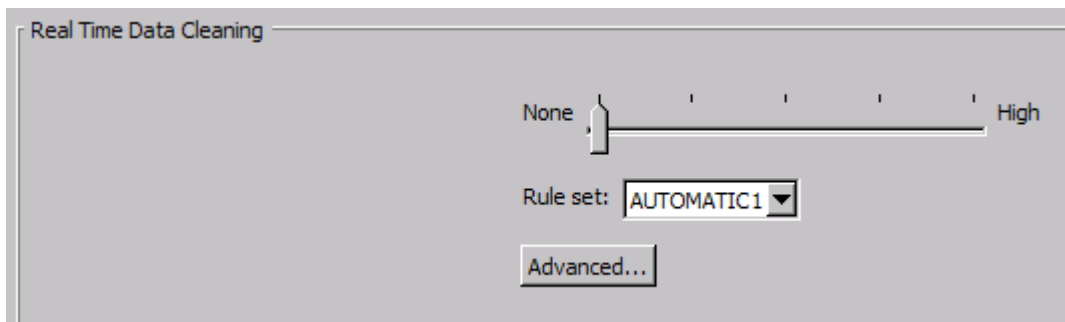

Slide selector: Used to select the level of data cleaning simply by using a slider within a range going from **None** to **High**. The range consists of five levels where each level is identified by a rule set predefined by Kongsberg Maritime. The rule sets are named *AUTOMATIC1*, *AUTOMATIC2* up to *AUTOMATIC5*. When a level has been selected the corresponding rule set is sent to the Grid Engine where the RTDC operation is performed.

Rule set: A pull down list containing all the predefined rule sets and, in addition, any custom made rule sets defined by the operator using the advanced setup display. See below. When a rule set has been selected it is made active and it is transferred to the RTDC module.

Advanced...: When this button is pressed the basic setup is replaced with an advanced setup allowing you to define new rule sets and modify or delete existing rule sets.

Advanced data cleaning

The RTDC (Real Time Data Cleaning) module processes the data in real time using two different kinds of processing, ping based and grid based processing. Ping based processing uses a buffer of the last pings to process current ping, also known as line-based processing. Grid based processing uses all points from all lines, current and all previous, to process the data in one grid cell. Various parameters are set to control these processing types.

Note

The real time data cleaning uses additional parameters which are not available to the user.

The advanced setup is organized with four different groups of rule parameters (ping processing, DTM processing, grid processing and seabed image processing) and one group for rule set administration/handling.

Rule set: A pull down list containing all rule sets, both predefined by Kongsberg Maritime (i.e. the rule sets within the 'None' to 'High' range) and custom made rule sets as defined by the operator. The parameter values for the selected rule set are shown in the parameter fields. I.e. by selecting a rule set, it's parameter values may be inspected or changed. Note however that the rule set is not automatically made active. Use the **Apply** or **OK** buttons to activate the parameter settings.

Delete: Delete the current rule set.

Note

Predefined rule sets (i.e. the rule sets within the "None" to "High" range defined by Kongsberg Maritime) or the current active rule set, can not be deleted. A warning is issued on an attempt to delete such a rule set.

Save as: When pressed a new rule set is created based on current rule set and parameter values. A rule set name must be given in the text field. The new rule set is made active by pressing **Apply** or **OK** and transferred to the RTDC module.

Note

The names of the predefined rule sets are not legal names for saving. A warning is issued on an attempt to use such a name.

OK: When pressed current settings will be saved to current rule set and the Advanced setup will be closed.

Apply: When pressed current settings will be saved to current rule set.

Note

*Predefined rule sets can not be changed. **Save As** must be use to make changes.*

Cancel: When pressed the advanced setup is closed without any changes. If **Apply** was pressed any changes since will not take effect.

Ping processing rules

Ping-based processing, flags wrong depths as early as possible in the processing chain. Ping processing is performed right after the depths arrive into the RTDC module. The **Time** rule and the **Overhang** rule use the current ping only.

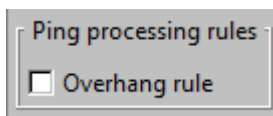

- **Overhang rule:** This rule flags beams that create an overhang situation, illustrated in the figure below.

Figure 21 Overhang rule

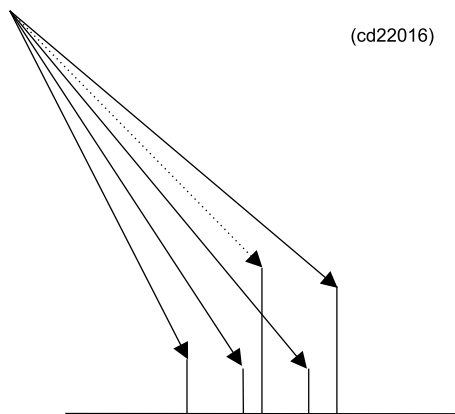

It is not unambiguously determined which beams to flag to remove the overhang. E.g. in the figure, it is possible to flag either the dotted beam or the beam to the left of the dotted beam. The strategy in SIS is to consider the alternatives that imply

flagging the fewest beams, and to keep the points that most likely define the seabed by minimizing the distances between the depths in the ping. If necessary, more than one beam is flagged to remove the overhang.

DTM processing rules

When the gridding starts, the operator has already defined the minimum grid cell size for the processing grid. However, the RTDC module checks if it needs to redefine this grid. It can do so by collapsing several grid cells into larger grid cells called **Cell Processing Units**. How many cells to process together is dependent on the median depth of the cells and the parameter Split factor.

The DTM and grid processing rules are applied to all depths in each grid cell. A grid cell defines an area, and all depths in this area are processed together regardless of the survey line they belong to. Every time a new depth is added to the grid cell, all depths (old and new) in the grid cell are reprocessed. Previous flagged out depths may be set to valid and vice versa during this process.

- **Min. no. points:** The parameter Min. no. points defines number of points in a grid cell. If a cell has fewer than this number of depths, all depths will be flagged out if the check button **Remove cells** is enabled.
- **Split factor:** Defines how many cells to process together. The value depends on the median depth of the cells.
- **Remove cells:** The parameter Min. no. points defines minimum points in a grid cell. If a cell has fewer points than the minimum number defined, all depths will be flagged out if this check button is enabled.
- **Surface fitting:** Sets parameters for a best fit plane. These parameters are discussed in detail in *Real time data cleaning* on page 492.
 - **Polynomial order:** This parameter controls the shape of the surface. This parameter is normally set to 1. Setting the polynomial order to 2 may give a better surface, but requires significantly more processing power. 3 may be used in very difficult terrain.
 - **Tukey constant:** This parameter controls the weight each point is given. Increasing this value means that more points will be considered into the solution, but the process will be slower.

- **Max. iterations:** This parameter controls how many times the Tukey algorithm will try to find a solution. 1 means that there will be only one pass. After 3 passes the surface is normally well defined. The search for a solution will stop when the algorithm has tried Max. iterations times.
- **Conv. criterion:** This parameter will stop the Tukey algorithm when the change in the results from the current and the previous run is very small. Only points with weight are considered, so the Tukey constant will have an influence on this.

Grid processing rules

Rule	Parameter	Value
<input type="checkbox"/> Residue depth rule	Factor	0.050
<input type="checkbox"/> Residue vertical error rule	Factor	1.000
<input type="checkbox"/> Residue avg. vertical error rule	Factor	1.000
<input type="checkbox"/> Residue std. rule	Factor	2.000
<input type="checkbox"/> Grazing angle rule	Min. angle	20.000

When the surface fitting for each Cell Processing Unit has been performed, points can be flagged out based on the following rules:

- **Residue depth rule:** Each depth in the Cell Processing Unit is multiplied with a Factor. The result is a limit, and if the residue is larger than this limit, the point is flagged out. This rule will adapt to changing depths, the factor is recommended set approximately to the accuracy of the echo sounder.
- **Residue vertical error rule:** Each depth has a vertical error estimate. This error estimate is multiplied with Factor and the result is a limit. If the residue is larger than this limit, the point is flagged out. This rule is also adaptive because the vertical error will change with the range and beam pointing angle.
- **Residue vertical avg. error rule:** In each cell the average vertical error is calculated, and the average vertical error for the Cell Processing Unit is then calculated. Further, a limit is calculated from the average vertical error in the Cell Processing Unit multiplied with Factor. If the residue is larger than this limit, the point is flagged out. Note that it is the average vertical error for the Cell Processing Unit that is used, not the cell's value.
- **Residue std. rule:** The standard deviation of the residue is also calculated. This is the standard deviation in the Cell Processing Unit, not the cell. A limit is set by multiplying Factor to this standard deviation. Residue larger than the limit are flagged out.

- **Grazing angle rule:** For each depth the angle between the beam and the bottom surface is calculated. Then the parameter **Min. angle** can be set to flag out all depths where the angle is less than this limit.

Seabed Image processing

When **Seabed Image Processing in GridEngine** is selected the seabed image data is also sent to the GridEngine and a seabed image mosaic is created.

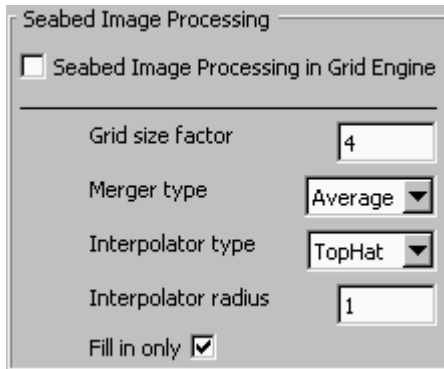

- **Grid size factor** is used to set the size of the sonar grid cells relative to the processing grid cells. E.g. if **Grid size factor** is set to 4, there will be 4 sonar grids for each processing grid.
- **Merger type** determines what action to be taken when more than one line fills a cell:
 - **Average** will calculate the average sidescan values for all passings over a cell
 - **Last Wins** will use last value only
- **Interpolator type:** Sometimes data is missing in an area. This can be filled with data from the surroundings using an interpolator. The interpolator type used is **Top Hat**.
- **Interpolator radius** determines the distance from an empty point in terms of number of cells that will be used in the interpolation. The less distance, the less interpolation will be done.
- **Fill in only** determines the interpolation to be carried out. If enabled, empty points only will be filled. If not enabled, the entire dataset will be smoothed.

Related operational procedures

- *How to display seabed imagery data in the Geographical view on page 162*

More information

- *Real time data cleaning on page 492*

GPS and delayed heave

The **GPS and delayed heave** parameters are located on the **Runtime parameters** display frame and contain options for logging of data files related to position and attitude data. These data can be used in post processing to improve the final seabed data.

The **GPS and delayed heave** options are the following:

- **Javad and Trimble setup** for setting up logging of raw observation data from either a **Javad** or a **Trimble** type GPS receiver. The Javad or Trimble raw data are logged in the **RTCM 3.0** raw data format that can be used in post processing to improve the position data.

Note

SIS does not support Precise Point Positioning based on Javad or Trimble raw data.

- **RTCM log parameters** for setting up logging of GPS raw data in the **RTCM 3.0** raw data format from a **Seapath 300** system. The logged GPS raw data is automatically formatted into **RINEX** format. SIS then offers a set of utility programs that further can be used to post process the GPS data to obtain sub-decimetre position data. In this process, the post processing software **TerraPOS** is used for applying precise clock and orbit corrections to the position data.

This method of improving the position accuracy is generally referred to as **Precise Point Positioning (PPP)**.

For description of Precise Point Positioning in SIS and description of how to use this utility, please refer to *Precise Point Positioning (PPP) in SIS* on page 476.

- **ATH log parameters** used to configure raw data logging from the **Applanix POSMV True Heave** system.
- **SRH log parameters** used to configure **Seapath Real Heave (SRH)** logging
- **PPP log parameters** for setting up logging of GPS raw data in the **PPP** raw data format from an **Applanix** system.

The logged GPS raw data is stored as **PPP** files and must be converted to **RINEX** format.

Note

The Rinex conversion is currently not available in SIS. This means that PPP processing is currently not fully implemented using PosMv-data even though the raw satellite data is logged.

If you attempt to change any of the parameters, the background colour of that field will change to yellow. The parameters are applied and used by pressing the **Apply** button, whereby the parameters are transferred to the logging process. The yellow background colour is removed.

When applying any parameter changes the any open log file is completed. The file interval timer is reset. If you want to continue the logging a new file is started according to the set parameters.

The **Cancel** button is used to revert any changes before using the **Apply** button

Parameters – Javad and Trimble setup

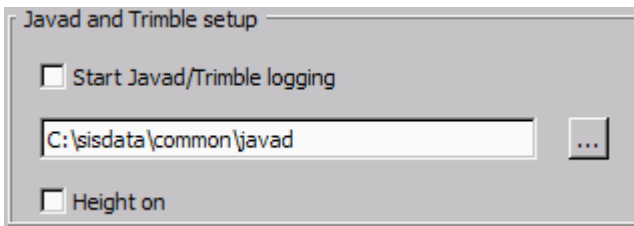

- **Start Javad/Trimble logging:** Enable/disable logging of stored Javad or Trimble GPS raw data.
- To specify the directory, use the browse button [...] to find or make the relevant directory.

Note

Note that the Javad/Trimble directory initially has a default setting. It is initially shown in the text field and it is also entered when the browse button is pressed.

- **Height on:** This tick button is used to turn fixed height on or off. Fixed height is on when ticked.

More information

- *Javad and Trimble details* on page 520

Parameters – RTCM log

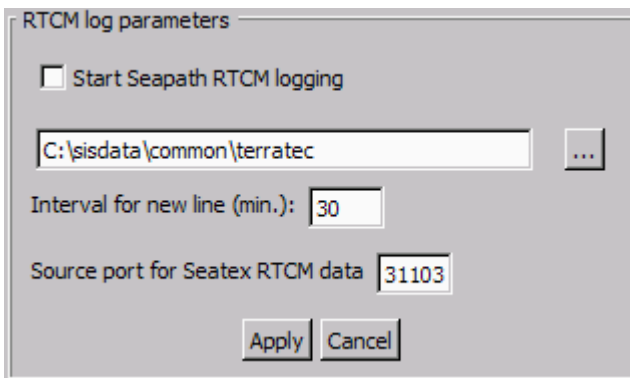

- **Start Seapath RTCM logging:** Enable/disable logging of GPS raw data in the RTCM 3.0 raw data format from a Seapath 300 dual frequency GPS system.
- To specify the directory, use the browse button [...] to find or make the relevant directory for storing the GPS raw observations.
- **Interval for new line (min):** Specifies interval in minutes between consecutive stored files, i.e. file size/length.
- **Source port for Seatex RTCM data:** UDP port number for the source data to be logged (according to Seapath configuration)
- **Apply and Cancel buttons:** Apply is used to confirm and activate the set parameters. Cancel is used to reset any changes before Apply is pressed.

When SIS is running the **Numerical display** frame, current **RTCM logging** status is displayed by selecting **RTCM Log**. The status is updated when a new file is created or as a result of changed RTCM logger parameter settings. When turning logging on for the first time the *ON* indication will not be displayed until the first RTCM signal is received from the Seapath.

A warning (pop-up) is issued if no logging input is received by the RTCM logger within 20 seconds.

More information

- *Precise Point Positioning (PPP) in SIS* on page 476
- *TerraPOS data format* on page 556

Parameters – ATH log

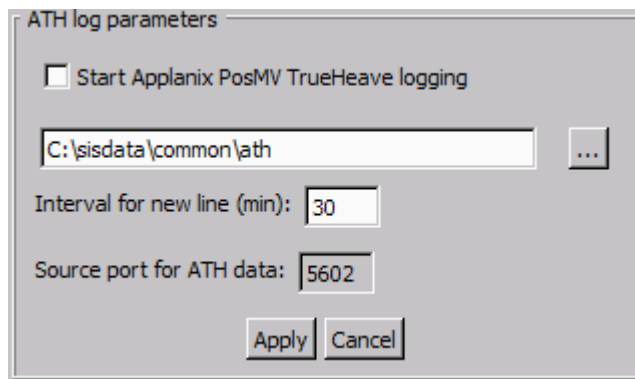

Note

ATH logging requires very accurate timing in the PU and it is recommended used only if ZDA clock and 1PPS is interface.

The SIS ATH process is designed to log the POSMV output on port 5602. A network connection between the POSMV and SIS must therefore be established. Please use the second network card in the HWS for this purpose, not the one connecting the HWS and the PU.

- **Start Applanix POSMV True Heave logging:** Enable/disable logging of ATH raw data from a POSMV attitude system.
- To specify the directory, use the browse button [...] to find or make the relevant directory for storing the ATH observations.
- **Interval for new line (min):** Specifies interval in minutes between consecutive stored files, i.e. file size/length.
- **Source port for ATH data:** Port number for the source data to be logged (according to POSMV configuration)
- **Apply** and **Cancel** buttons: Apply is used to confirm and activate the set parameters. Cancel is used to reset any changes before Apply is pressed.

ATH file format

The naming format of the logged files stored by the ATH logging process is as follows:

ATH_YYYY_MM_DD_SSSSSS_.ath

Where

- YYYY_ = Year (four digits)
- MM_ = Month (two digits)
- DD_ = Day (two digits)
- SSSSSS_ = Seconds since start of week (six digits)

e.g.:

ATH_20060915_123456.ath

More information

- *ATH data format* on page 551

Parameters – SRH log

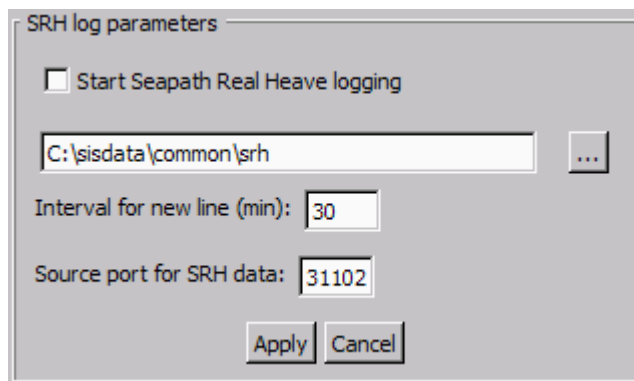

Seapath Real Heave (SRH) data is delayed by a few minutes due to internal processing. It can be logged by SIS and subsequently used in post processing. The **SRH logging** facility consists of two components: the **SRH logger process** and the **SIS SRH logger interface**. SRH logging must be started and controlled from the SIS SRH logger interface.

When SIS is started an SRH logger process is also started. Whether the actual logging operation is started or not depends on the last logger setting used.

When SIS is stopped the SRH logger process is also stopped.

- **Start SRH logging:** Enable/disable logging of realtime heave data from a Seapath system.
- To specify the directory, use the browse button [...] to find or make the relevant directory for storing the realtime heave observations.
- **Interval for new line (min):** Specifies interval in minutes between consecutive stored files, i.e. file size/length.
- **Source port for SRH data:** Port number for the source data to be logged (according to Seapath configuration)

- **Apply** and **Cancel** buttons: Apply is used to confirm and activate the set parameters. Cancel is used to reset any changes before Apply is pressed.

When SIS is running the **Numerical display** frame, current **SRH logging** status is displayed by selecting **SRH Log**. The status is updated when a new file is created or as a result of changed SRH logger parameter settings. When turning logging on for the first time the *ON* indication will not be displayed until the first SRH signal is received from the Seapath.

A warning (pop-up) is issued if no logging input is received by the SRH logger within 20 seconds.

Note that there is no initial 200 sec. wait for the SRH data to arrive, it is assumed that the Seapath system is up and running before logging starts (if not the 20 sec. warning will be issued, one or several times).

SRH file format

The name of the logged SRH file has the following format:

```
SRH_YYYYMMDD_EPOCHSEC.srh
```

where the date and time is the current UTC time at the time of file creation and EPOCHSEC is the number of seconds since the epoch, 1970-01-01, fetched from the first signal logged in the file.

The format of the information stored in the file is the length of the received signal (unsigned short, i.e. 2 bytes) and then the signal itself.

More information

- *SRH data format* on page 555

Parameters – PPP log

Precise Point Positioning (PPP)

- **Start Applanix PosMV PPP (raw GPS) logging:** Enable/disable logging of PPP files.
- To specify the directory, use the browse button [...] to find or make the relevant directory for storing the realtime heave observations.
- **Interval for new line (min):** Specifies interval in minutes between consecutive stored files, i.e. file size/length.

- **Source port for ATH data:** Port number for the source data to be logged (according to PosMV configuration)
- **Apply** and **Cancel** buttons: Apply is used to confirm and activate the set parameters. Cancel is used to reset any changes before Apply is pressed.

When SIS is running the **Numerical display** frame can display the current **PPP logging** status by selecting **PPP Log.** item. The status is updated when a new file is created or as a result of changed PPP logger parameter settings. When turning logging on for the first time the *ON* indication will not be displayed until the first PPP signal is received from the POSMV.

A warning (pop-up) is issued if no logging input is received by the PPP logger within a defined interval, currently set to 20 sec.

A warning is issued if the signal input rate falls to an unacceptable level.

More information

- *Precise Point Positioning (PPP) in SIS* on page 476
- *TerraPOS data format* on page 556
- *Sensor options* on page 348

Simulator for EM 2040

Simulator is located under the **Runtime parameters** frame.

Parameters – Simulation setup

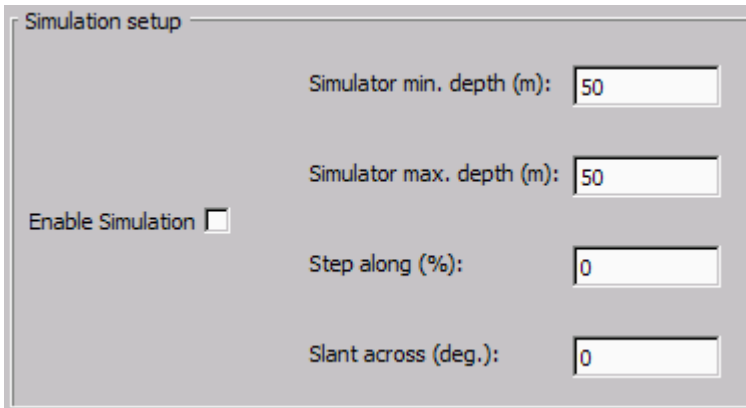

Simulation setup

Enable Simulation

Simulator min. depth (m): 50

Simulator max. depth (m): 50

Step along (%): 0

Slant across (deg.): 0

Enable Simulation: Select this parameter to enable simulation mode in the echo sounder.

Simulator min. depth (m): Set the minimum depth for simulation.

Simulator max. depth (m): Set the maximum depth for simulation.

Note

The simulation generates range samples only. All other inputs to the PU (Processing Rack in the Transceiver Unit) must be supplied via the normal PU input ports. Most important is the position data and roll, pitch and heave (i.e. attitude data).

Step along (%): The change in depth between each ping given in percent. The depth will vary within the set min/max range.

Slant across (deg.): The tilt of the sea bottom across track in degrees.

Figure 22 Step along

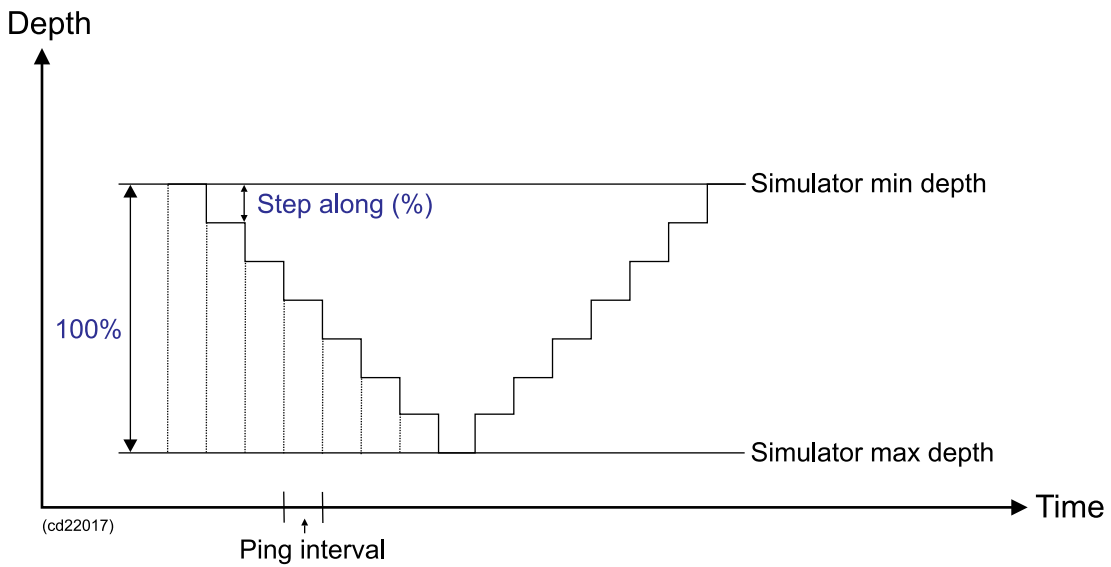
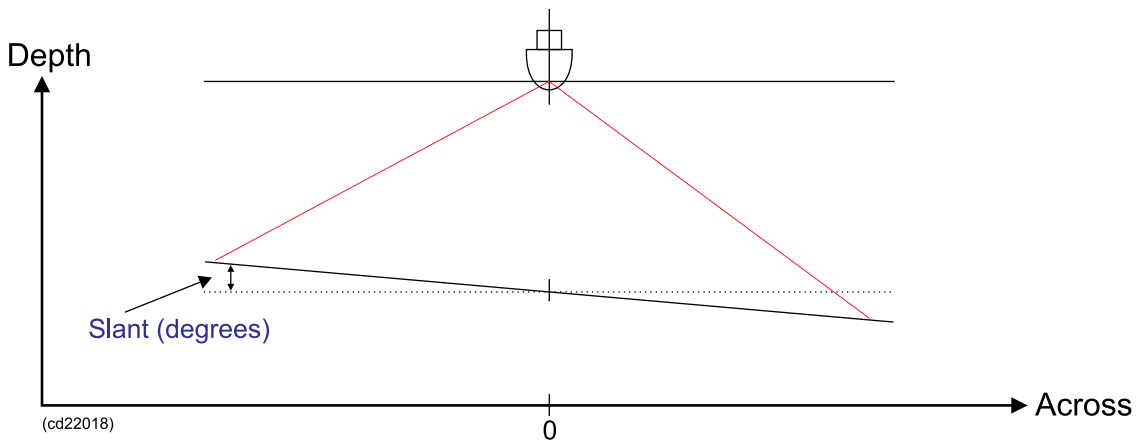
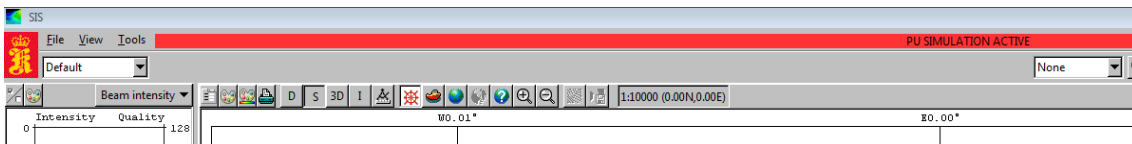

Figure 23 Slant across



When simulation is enabled (i.e. active), the transmit (TX) circuits in the processing unit will be disconnected and it is not possible to operate the echo sounder.

A red bar indication above the **Main toolbar** in the SIS application window will notify the operator when the system is running in simulator mode.



Parameters – Beam no. for Scope Display

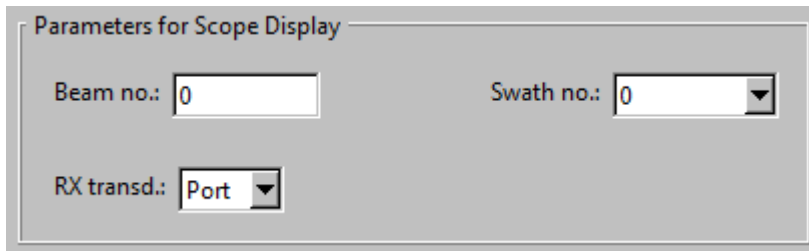

Parameters for Scope Display

Beam no.: Swath no.: ▼

RX transd.: ▼

Beam no.: Set beam number to be displayed in the **Scope Display**. Set beam number to zero (0) if you want to turn off this feature.

Swath no.: Set which swath number to be displayed. Set swath number to zero (0) if you want to display a scope beam from the foremost swath.

RX transd.: Select **Port** or **Starboard** transducer for the scope beam.

Survey Information

Survey Information is located under the **Runtime parameters** frame. The **Survey Information** tab displays survey parameters for the active survey. The information is automatically selected.

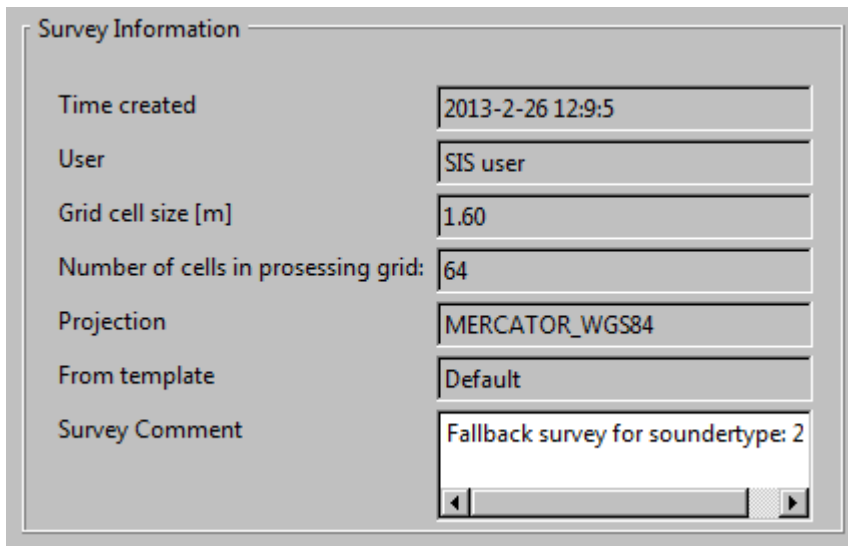

The screenshot shows a dialog box titled "Survey Information" with the following parameters:

Time created	2013-2-26 12:9:5
User	SIS user
Grid cell size [m]	1.60
Number of cells in processing grid:	64
Projection	MERCATOR_WGS84
From template	Default
Survey Comment	Fallback survey for soundertype: 2

Note

*The **Survey Information** for GPS do not show the **Grid cell size** and **Number of cells**:*

For more information about **Survey parameters** see:

Parameter references

- *Survey parameters* on page 263

SIS parameters – Set parameters

This section contains a description of the dialog boxes and parameter settings that are used to control the behaviour of SIS.

These parameters are all found from the main menu by selecting **Tools**→**Custom...**→**Set Parameters**.

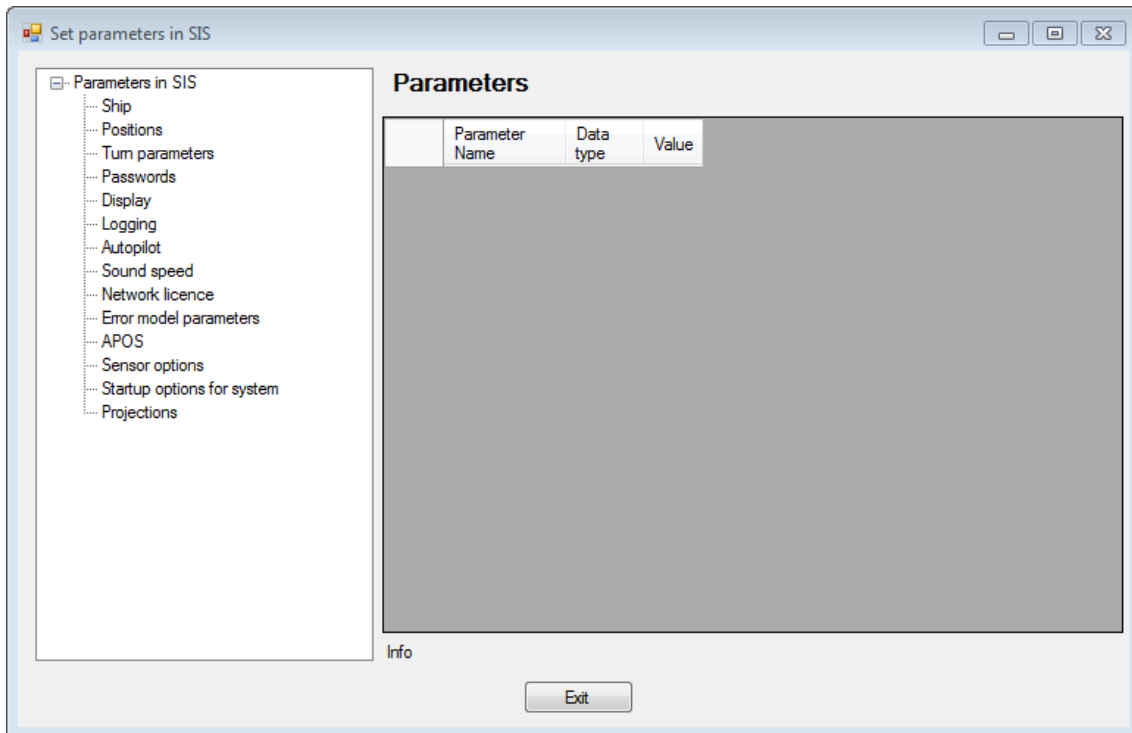

Select a topic on the branch in the tree to the left, and the window to the right will expand.

Select this topic	To
Ship	Define the appearance of the ship in the Geographical view
Positions	Error limits and filter settings for positions
Turn parameters	For planning turns in the Planning module
Passwords	Passwords for different users
Display	Parameters controlling the Geographical view
Logging	Define logging parameters. Select grid engine (GridEngine/CUBE)
Autopilot	Set autopilot parameters
Sound speed	Set sound speed masks
Network licence	Identify your license server
Error model parameters	Parameters for Total Propagation Error
APOS	Relay position computed by APOS software to SIS
Sensor options	Alarm threshold setting for loss of attitude data
Startup options for system	Set configuration of start-up behaviour in SIS and the PUs
Projections	Set location for Gauss-Krüger projection file

Ship parameters

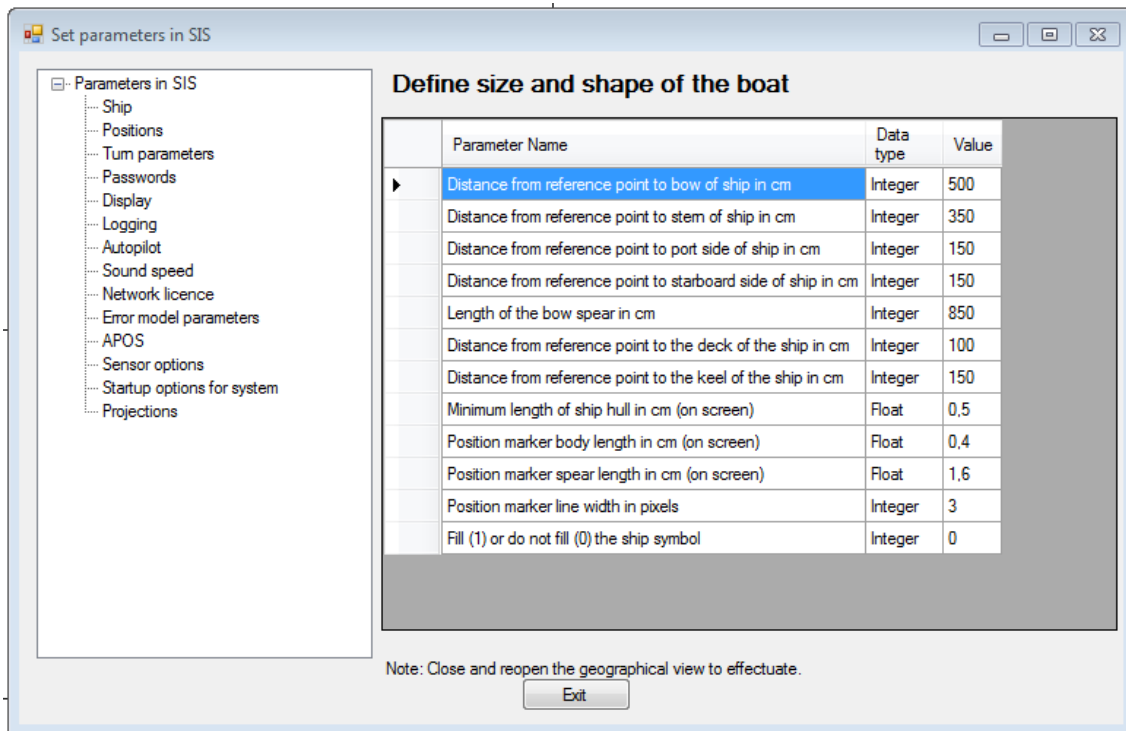

It is recommended to set the appearance of the ship to visualize the actual size of your ship. When the display is zoomed out beyond a set limit, the ship will appear as a position marker, i.e. a triangle, with a spear. The following ship parameters can be set:

- Fill
- Line width in pixels
- Position marker spear length – the length of the spear, in cm on the screen, when the ship is displayed as a position marker
- Position marker body length – the size of the position marker (triangle base and length) when the ship is displayed as a position marker
- Minimum length of ship hull – the scaled size of the ship, in cm on the screen, where the position marker will take over at further zooming
- Distance from reference point to the keel, to the deck, to starboard, to port, to stern and to bow – the actual size that defines your ship. Input the values in cm. E.g. if the distance from the reference point to the stern is 40 meters, 4000 centimetres must be entered.
- Length of the bow spear – the bow spear is a imaginary line in front of the ship to assist in steering it straight.

Note

The geographical view needs to be closed and reopened to effectuate any changes.

Note

The ship size will be scaled according to actual scale in the geographical view. The position marker size will remain unchanged.

Note

When a projection with scale factor is applied, e.g. UTM projection, the ship size will be scaled accordingly.

Note

Enter the values of the parameters according to the type shown for each field, i.e. integer number, float number or text.

Positions

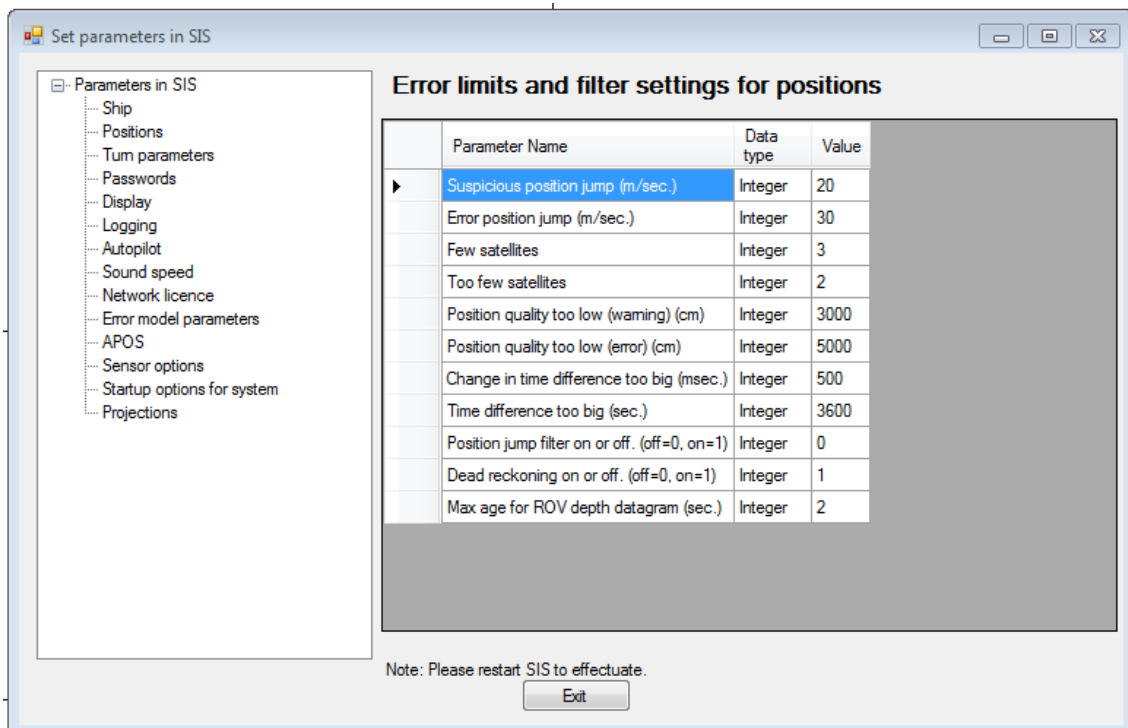

The following masks related to position input can be set:

- Max age for ROV depth datagram (sec.). Time before a missing ROV depth input datagram to the echo sounder (PU) is flagged in the numerical display. Must never be set to 0.
- Dead reckoning on or off. (off=0, on=1). If position input stops the dead reckoning feature will calculate predicted positions for a preset time interval before stopping. The predicted positions are based on the two last positions received and the (still) incoming heading, if available. If not, the last heading will be used

- Position jump filter on or off. (off=0, on=1). This filter is used to remove single spikes in the position input. If a position spike occur this position is disregarded and a predicted position used instead. This predicted position is based on the two previous (legal) positions and the heading.
- Time difference too big (sec): If the time difference between the timestamp and the time in the clock datagram is bigger than this value, an error is generated.
- Change in time difference too big (millisec): There is always a time difference between the timestamp and the time in the clock datagram. However, this time difference is expected to be almost constant. If there is a sudden change in the difference, an error is generated.
- Position quality too low (error) (cm): Lowest acceptable limit for the computed position quality (see position datagram output in the corresponding echo sounder manual).
- Position quality too low (warning) (cm): Warning limit for the position quality.
- Too few satellites: Lowest number of satellites before an error is generated.
- Few satellites: Lowest number of satellites before a warning is generated.
- Error position jump (m/s): Highest possible speed of the ship. This is used to generate error messages for position jumps.
- Suspicious position jump (m/s): Warning message is generated when position jump exceeds this limit.

Note

SIS needs to be restarted to effectuate any changes.

Turn parameters

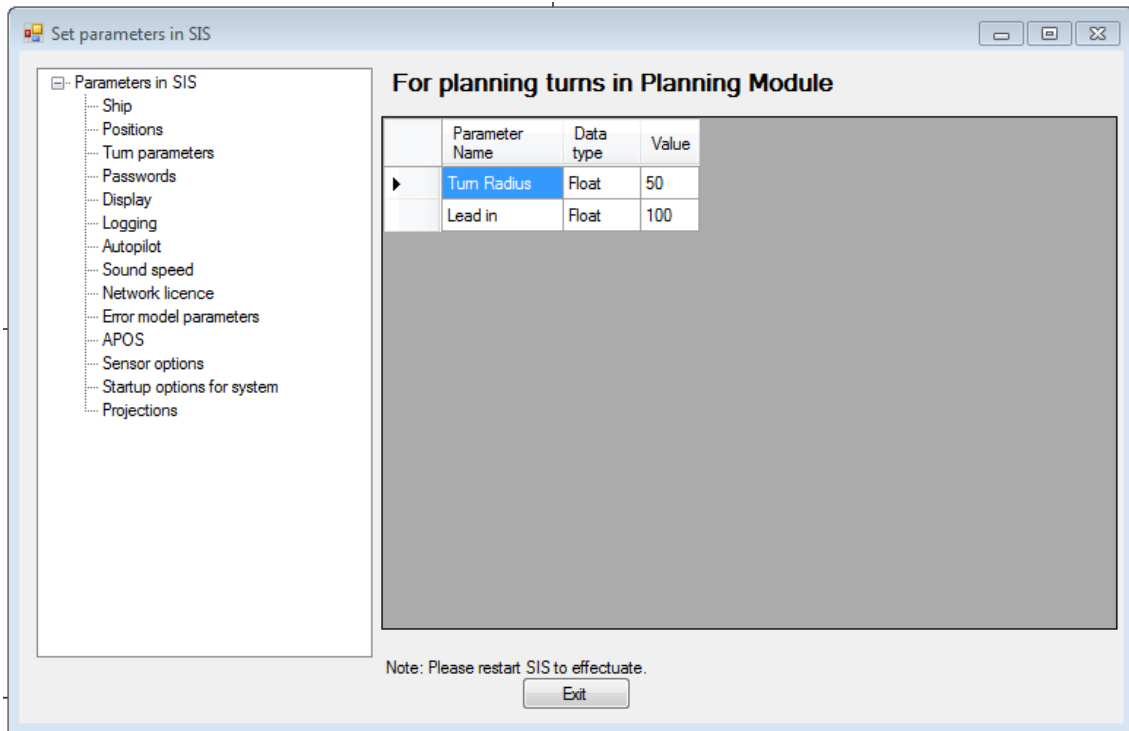

These parameters are used to control how generate turns from one planned line to the next in the SIS planning module

- Lead in: Extend each planned line to allow the ship to stabilize before entering the survey line.
- Turn radius: The minimum turn radius in meters that the ship can do.

Note

SIS needs to be restarted to effectuate any changes.

Password

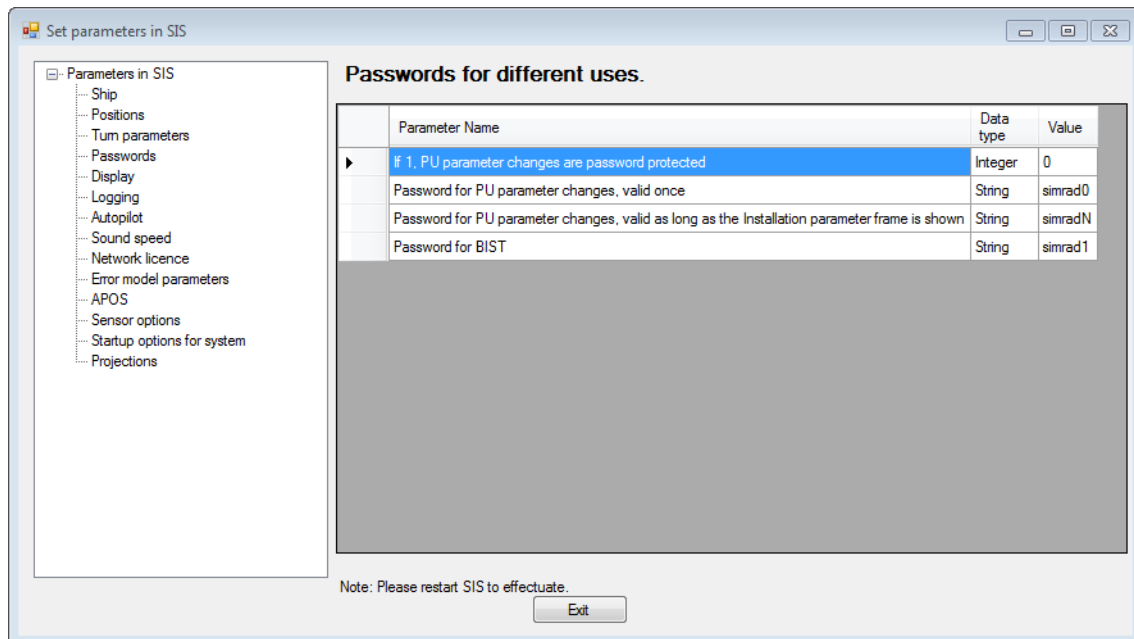

The **installation parameters** may be password protected. These parameters control the use of passwords in SIS.

- Password for BIST
- Password for installation menu, valid as long as the frame is shown
- Password for installation menu, valid once
- If 1: Installation menu is password protected: Set this parameter to 1 to enable the use of passwords, 0 to disable

Note

SIS needs to be restarted to effectuate any changes.

Display

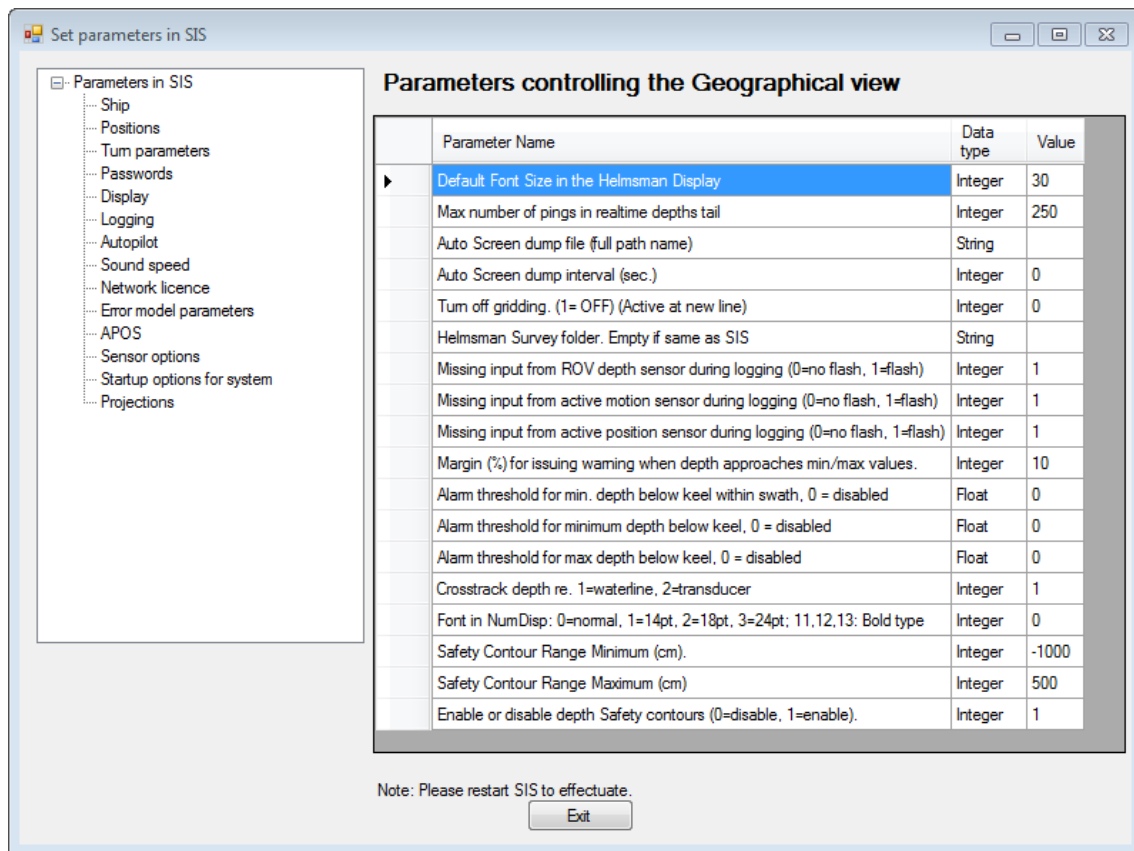

The **Display** parameters can be set as follows

- Default Font Size in the Helmsman Display. Control the font size in the Helmsman Display, both the display in SIS and the display in the Remote Helmsman application.
- Max number of pings in realtime depths tail. The length of the realtime depth tail behind the ship in the geographical view.
- Auto screen dump file (full path). File default extension is `.gif`. The file is updated with the interval defined above. The file is readable by e.g. a WEB application for periodic display
- Auto screen dump interval (in seconds) defines how often a screen dump of the SIS GUI is performed
- Turn off gridding – it is possible to turn gridding off when logging data.
- Helmsman Survey folder. Empty if same as SIS.

If the Remote Helmsman run on a separate computer, the survey folder on the SIS computer where the shiptrack and coverage files are stored, has to be shared and mapped on the remote PC. If the folder is mapped to a different drive letter on the Helm PC, the folder has to be set. The format of the folder name has to be "Drive Letter":\sisdata\grid or the complete folder name in front of the survey name. If the folder is `g:\sisdata\grid` on the SIS PC and accessible as `h:\sisdata\grid` on the Helm PC, you must enter `h:\sisdata\grid`.

- Missing input from ROV depth sensor during logging (0=no flash, 1=flash). SIS flashes red if set to 1 and ROV depth data is lost.
- Missing input from active motion sensor during logging (0=no flash, 1=flash). SIS flashes red if set to 1 and attitude data is lost.
- Missing input from active position sensor during logging (0=no flash, 1=flash). SIS flashes red if set to 1 and position input data is lost.
- Margin (%) for issuing warning when depth approaches min/max values. A warning will be given when you are within given margin of the min/max depth thresholds. The margin is entered as a percentage of the depth limit.
- Alarm threshold for min. depth below keel within swath (0=disabled). An alarm will be given if a depth within the swath is below given threshold.
- Alarm threshold for minimum depth below keel (0=disabled). An alarm will appear if you are in too shallow waters.
- Alarm threshold for max depth below keel (0=disabled). An alarm will appear if you are in too deep waters.
- Crosstrack depth re. 1=waterline, 2=transducer. Depth text optionally shown in the Crosstrack view will be referred to either of the parameters selected here.
- Font in NumDisp: 0=normal, 1=14pt, 2=18pt, 3=24pt; 11,12,13: Bold type. The font size used in **Numerical Display** can be changed. The following options are available:
 - 0 = Normal font
 - 1 = 14 points font size
 - 2 = 18 points font size
 - 3 = 24 points font size
 - 11 = 14 points font size, bold
 - 12 = 18 points font size, bold
 - 13 = 24 points font size, bold
- Safety Contour Range Minimum (cm). This parameter sets the minimum depth value of the Safety Contour range. This is the minimum value in the range and is generally a negative number which indicates that the value is above the waterline.
- Safety Contour Range Maximum (cm). This parameter sets the maximum range value of the Safety Contour. The maximum depth value of the Safety Contour range is computed by subtracting the current Tide value from this parameter.
- Enable or disable depth safety contours (0=disabled, 1=enable). This parameter enables the Safety Contour feature in **Geographical view**. The Safety Contour feature is enabled as default.

This feature provides a means to define a range of depth below which it is deemed too shallow for the survey vessel when accounting for the current tide. This range of depths can be shown in any single colour.

Note

SIS needs to be restarted to effectuate any changes.

Logging

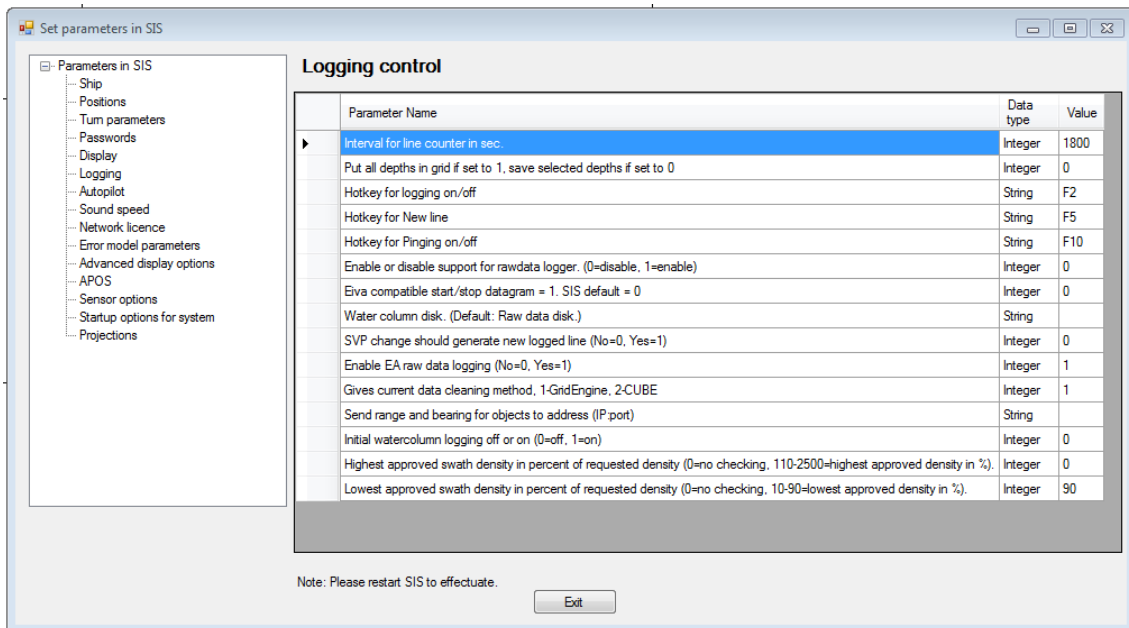

The following **logging** parameters can be set:

- Interval for line counter in sec.: Control when new survey lines are automatically generated.
- Put all depths in grid if set to 1, save selected depths if set to 0: The operator can choose to put all depths into the real time terrain model or not. If not, there is a maximum value of 25 soundings per grid cell, which normally is more than enough, but if set, this limit is overridden.
- Selection of hotkeys for pinging/logging/new-line.
- Enable/Disable support for raw data logger in PU.

Raw data logging can be performed by the PU itself to a local hard disk in parallel with the logging operation in SIS.

- Eiva compatible start/stop datagram = 1. SIS default = 0.
Eiva is a third party Remote Helmsman that requires a different start/stop identification than SIS Remote Helmsman uses.

- Water column disk. (Default: raw data disk)

It is possible to log the separate water column files to a separate disk instead of using the same location as for the raw data ('.all?') files. This will prevent fragmentation of both the raw data files as well as the water column files.

- SVP change should generate new logged line. Yes=1, No=0

Automatic creation of new logged line when a new SVP is activated. A new sound velocity profile is activated either when the user manually select it from **Runtime Parameter**→**Sound Speed** or when an SSP datagram for immediate use (S00 - S07) is received by SIS.

- Enable EA raw data logging (No=0, Yes=1): Must be enabled to do logging of raw data from the interfaced singlebeam system.

- Gives current data cleaning method, 1=GridEngine, 2=CUBE: This parameter controls if SIS shall use GridEngine or CUBE to generate terrain models.
- Send range and bearing for objects to address (IP:port): When the operator uses the Distance-tool (i.e. The Compass button) in the map-window to measure range and bearing to objects, this information is sent to an external port. This address can be set here.
- Initial water coloumn logging off or on (0=off, 1=on): If initial logging is turned on (1=on), SIS will always start with water column logging enabled. However, the operator is still allowed to disable water column logging at any time, if required.
- Highest approved swath density in percent of requested density: This parameter controls if and when a warning should be issued if the data density is to high. The default value is 0, which means no warning. The legal range is 110–2550% in 10% increments.
- Lowest approved swath density in percent of requested density: This parameter controls if and when a warning should be issued if the required data density can not be obtained. A value of 0 indicates that no warning for this feature are issued. The default warning limit is a swath density of 90% of the requested density. The legal range is 10–90% in 10% increments.

Note

SIS needs to be restarted to effectuate any changes.

Related operational procedures

- *How to interface a singlebeam echo sounder in SIS* on page 156
- *How to log water column data* on page 170
- *How to enter survey parameters* on page 114

Related topics

- *Hotkeys* on page 46
- *Geographical – Compass button* on page 223
- *CUBE* on page 464

Autopilot

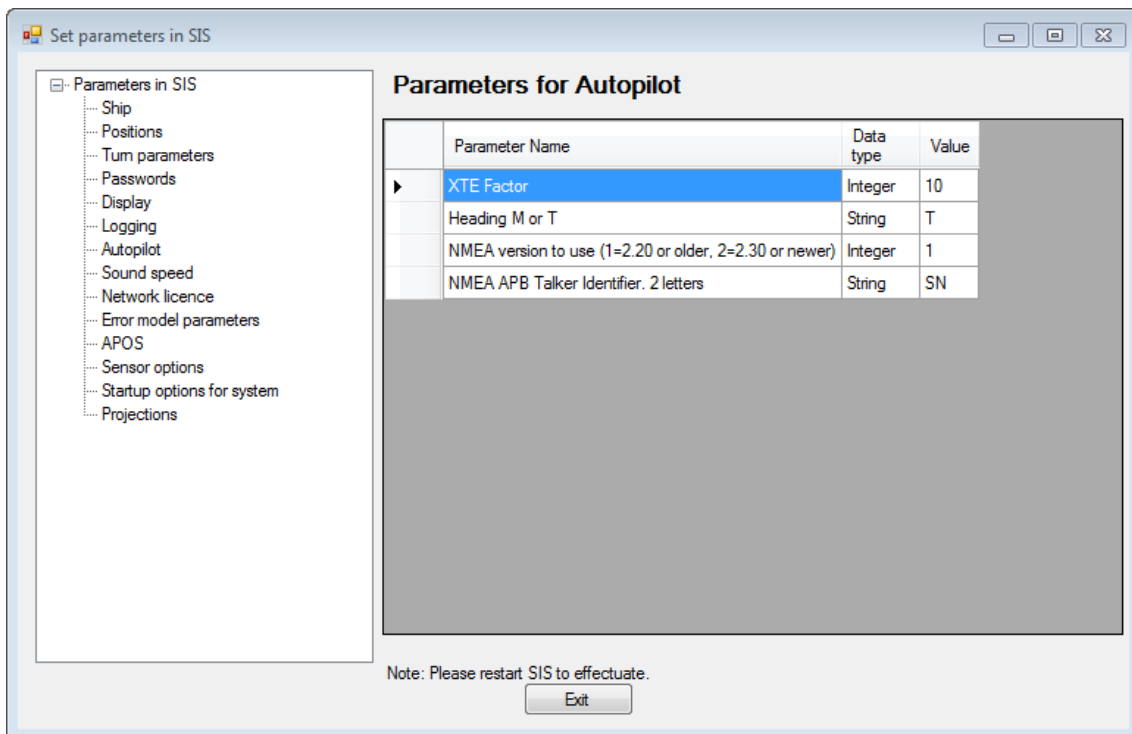

The following **Autopilot** parameters can be set:

- NMEA APB Talker Identifier, 2 letters: The NMEA datagram start with an address field that identifies the sender (talker). You can change the this field according to your requirements.
- NMEA version to use determined by readability in the autopilot system
- Heading M or T: The output from SIS to the AP is normally true heading, T. However, sometimes the AP requires this to be Magnetic, and then this can be set accordingly, Note that the heading calculated in SIS is still True heading, so this is just to be used in case the AP cannot use True heading.
- XTE factor: the XTE value in the NMEA APB datagram is multiplied with this factor. This can cause the autopilot to react more quickly, but it can make the ship oscillate along the line. This factor must be used with care.

Note

SIS needs to be restarted to effectuate any changes.

Sound speed

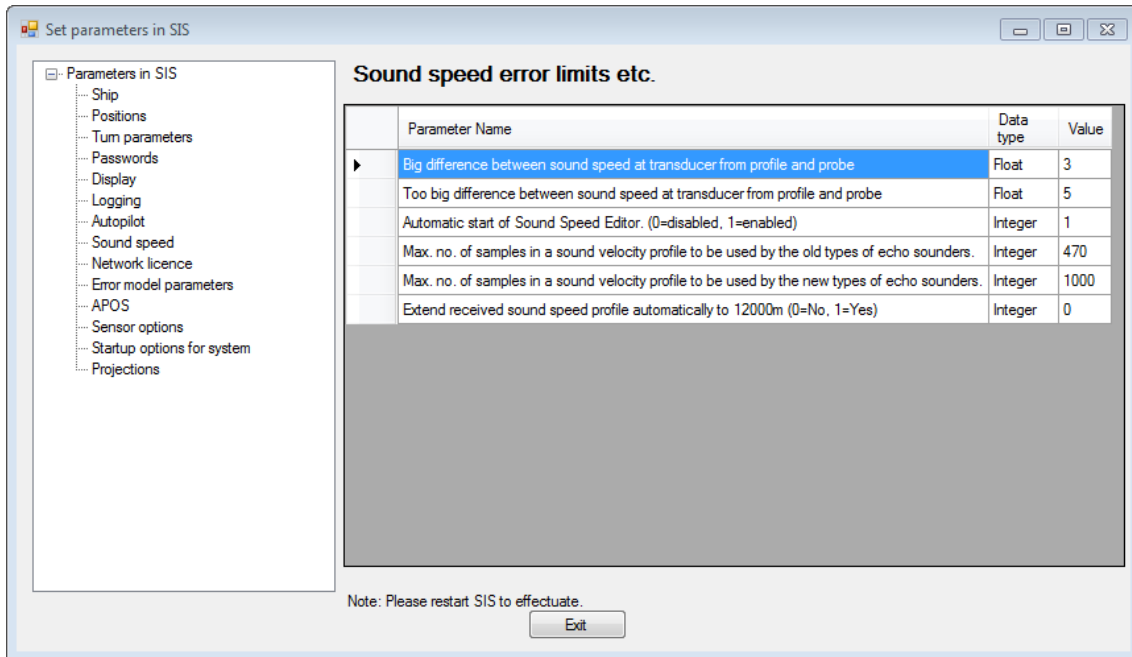

The following **sound speed** parameters can be set:

- Big difference between sound speed at transducer from profile and probe – limit for generation of warning
- Too big difference between sound speed at transducer from profile and probe – limit for error generation
- Automatic start of Sound Speed Editor. Enable/disable
- Max. no. of samples in a sound velocity profile to be used by the old types of echo sounders.
- Max. no. of samples in a sound velocity profile to be used by the new types of echo sounders.
- Extend received sound speed profile automatically to 12000m (0=No, 1=Yes). This parameter enables automatic extension of the sound speed profile.

All sound velocity profiles received by SIS must extend to 12000 meter. If this function is enabled SIS will provide the extension automatically if the received sound velocity profile is shorter than 12000 m. The extension will be performed from the last depth available in the received profile, and a simple algorithm will be employed to give a smooth transition. In addition the profile will also be extended upwards to 0 m if not already present. The upwards extension is done by using the first sound speed sample found.

Note

SIS needs to be restarted to effectuate any changes.

Network licence

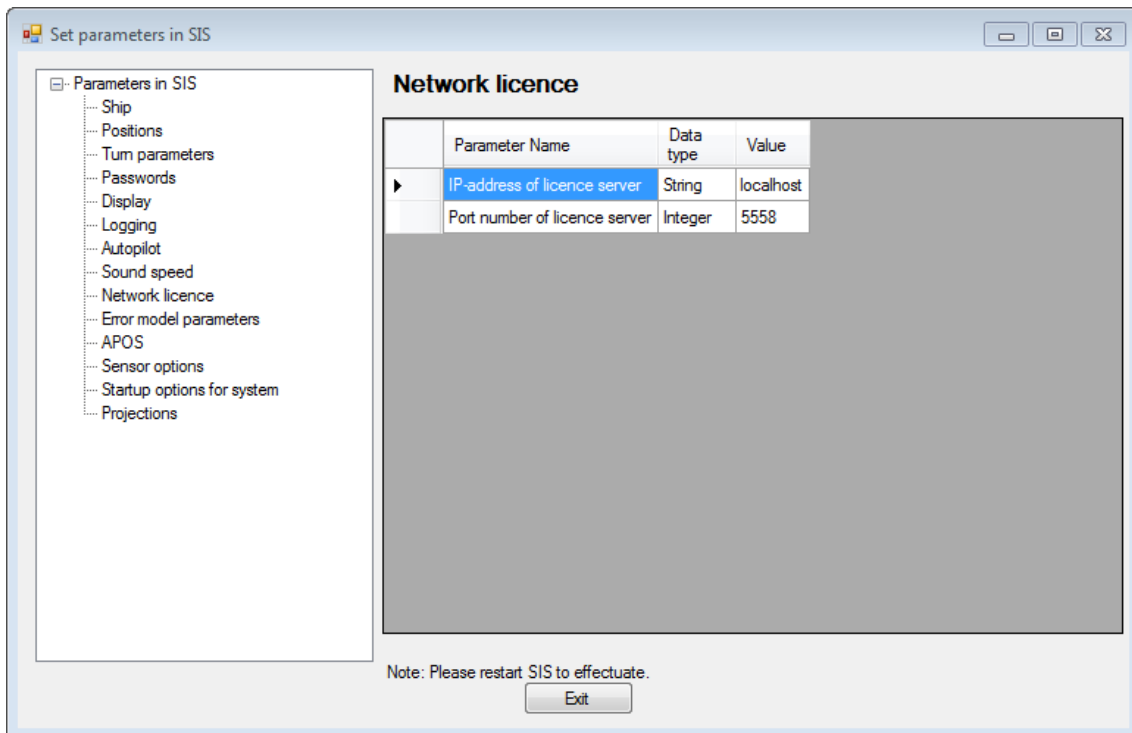

The following **network licence** parameters can be set:

- Port number of licence server
- IP-address of licence server

Note

SIS needs to be restarted to effectuate any changes.

Error model parameters

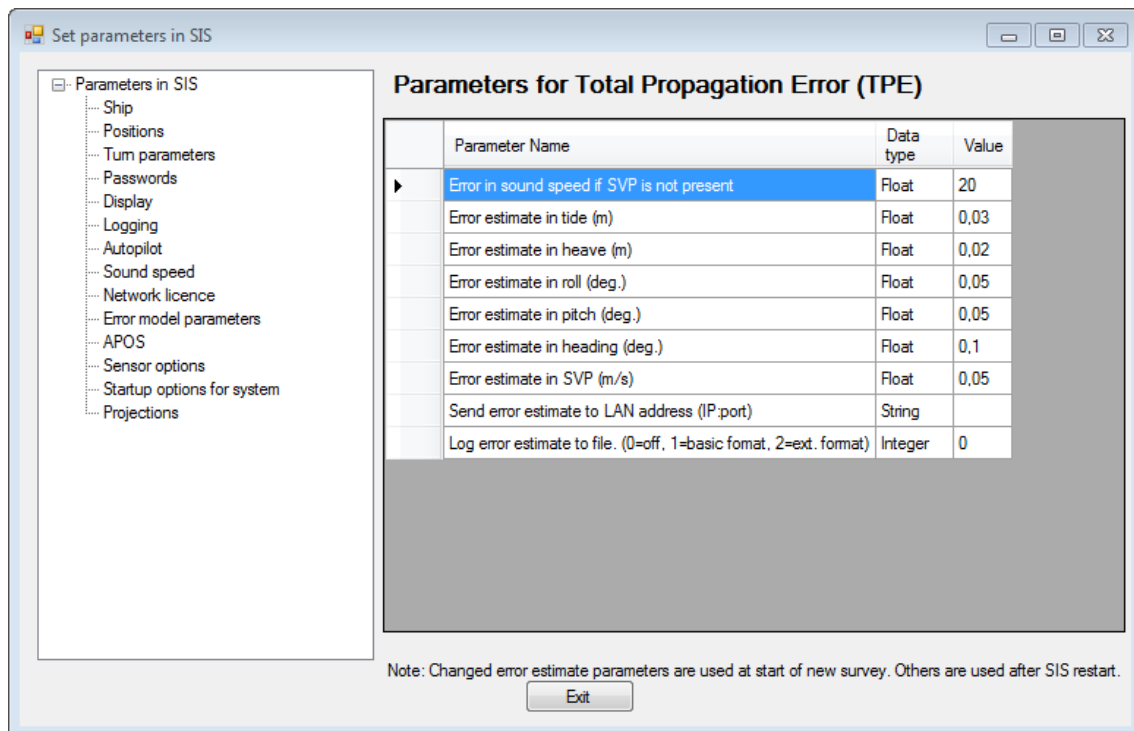

Enter the error estimates for the attitude sensor, SVP and tide. The error estimate values refers to the Total Propagation Error described in *Real time data cleaning* on page 492. The values are specific to the sensor types and must be set according to the system specifications. These parameters are used in calculating the error estimate for the depth values.

Note

Parameters will be updated when a new survey is started.

APOS

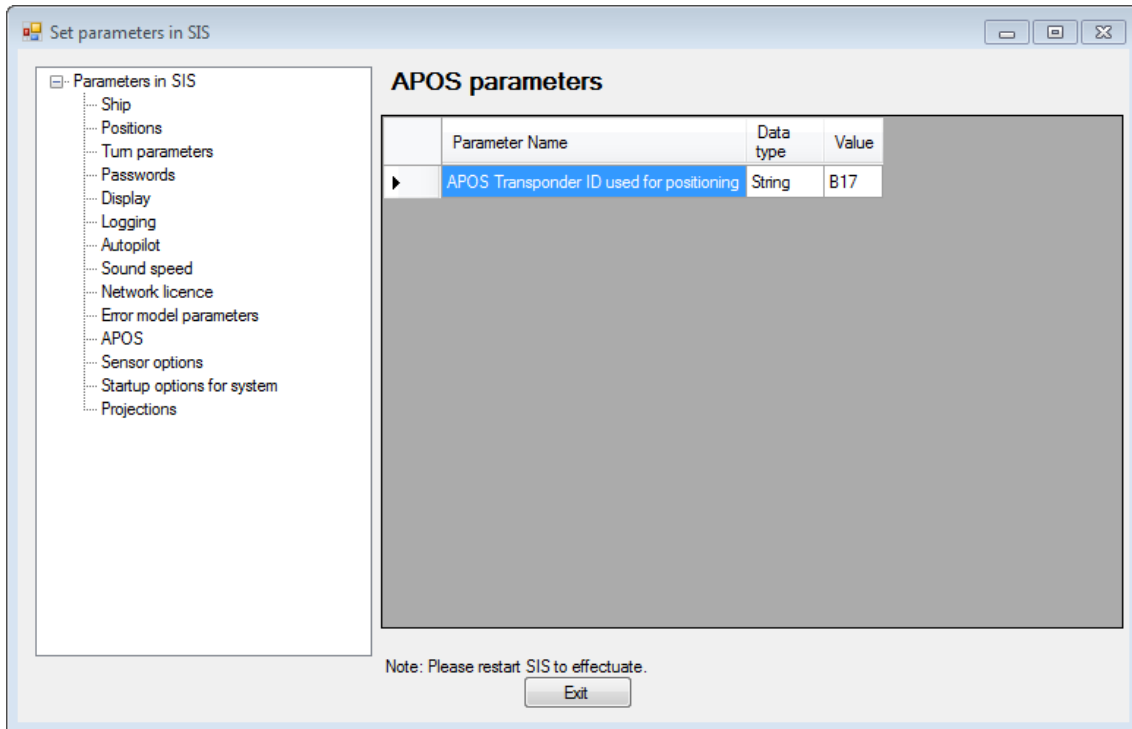

APOS is a Kongsberg Maritime acoustic positioning operating station - a computer with a Windows based operating software. Position computed by APOS based on reference to a fixed transponder on the seabed can be relayed to SIS and be used as position reference for the echo sounder. To enable the use of APOS positions, the following procedure must be used (Windows platform only)

- 1 Run **findDDSPort** from a command prompt window to find the UDP port where the APOS positions are sent to
Use that port and the SIS PC's IP address when configuring APOS
- 2 Enter the Transponder ID in the text field as shown in the figure above
- 3 Open the **Installation parameter** frame for the desired echo sounder and under "Input Setup – Port Settings" enable GGA on UDP2. On "Sensor Setup", select UDP2 as the active position system
- 4 Enable GGA on UDP2 from **Input setup**→**Port settings**
- 5 Select **UDP2** as active position system from **Sensor setup**

Note _____

SIS needs to be restarted to effectuate any changes.

Sensor options

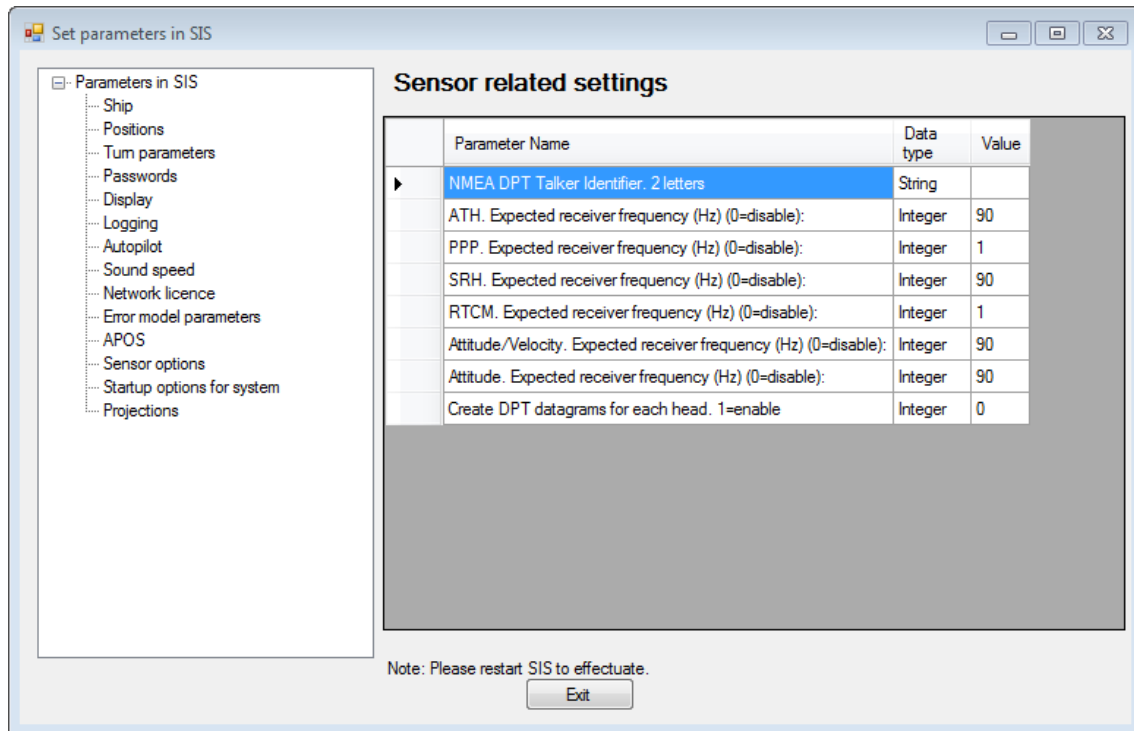

The following **sensor related settings** parameters can be set:

- NMEA DPT Talker Identifier. 2 letters. This parameter defines the 2 characters to identify the type of equipment that sends the NMEA datagram.
- ATH. Expected receiver frequency (Hz) (0=disable). This parameter defines the expected reception rate of the TrueHeave (ATH) input. The default expected reception rate is 90 Hz, and the warning can be disabled by selecting 0.

The ATH receive frequency can be monitored from the ATH logger to give a warning if it falls 90 % below expected rate. If a low reception rate is detected this is indicated by a warning. The checking of the ATH reception rate is done in a cycle of 10 seconds active monitoring followed by a pause of 50 seconds. This implies that one minute might pass before a low reception rate is reported.

- PPP. Expected receiver frequency (Hz) (0=disable). This parameter defines the expected reception rate of the Precise Point Positioning (PPP) input. The default expected reception rate is 1 Hz, and the warning can be disabled by selecting 0.

The PPP receive frequency can be monitored from the PPP logger to give a warning if it falls 90 % below expected rate. If a low reception rate event occurs this is indicated by a warning. The checking of the PPP reception rate is done in a cycle of 10 seconds active monitoring followed by a pause of 50 seconds. This implies that one minute might pass before a low reception rate is reported.

- SRH. Expected receiver frequency (Hz) (0=disable). This parameter defines the expected reception rate of the RealHeave (SRH) input. The default expected reception rate is 90 Hz, and the warning can be disabled by selecting 0.

The SRH receive frequency can be monitored from the SRH logger to give a warning if it falls 90 % below expected rate. If a low reception rate event occurs this is

indicated by a warning. The checking of the SRH reception rate is done in a cycle of 10 seconds active monitoring followed by a pause of 50 seconds. This implies that one minute might pass before a low reception rate is reported.

- RTCM. Expected receiver frequency (Hz) (0=disable). This parameter defines the expected reception rate of the RTCM input. The default expected reception rate is 1 Hz, and the warning can be disabled by selecting 0.

The RTCM receive frequency can be monitored from the RTCM logger process to give a warning if it falls 90 % below expected rate. If a low reception rate event occurs this is indicated by a warning. The checking of the RTCM reception rate is done in a cycle of 10 seconds active monitoring followed by a pause of 50 seconds. This implies that one minute might pass before a low reception rate is reported.

- Attitude/Velocity. Expected receiver frequency (Hz) (0=disable). This parameter defines the expected reception rate of the Attitude/Velocity input. The default expected reception rate is 90 Hz, and the warning can be disabled by selecting 0.

The Attitude/Velocity receive frequency on echo sounder ports UDP5 and/or UDP6 can be monitored to give a warning if it falls 90 % below expected rate. If a low reception rate event occurs this is indicated by a warning indication (Yellow) in the PU sensor status display for the Attitude/Velocity sensor on the relevant port (UDP5 or UDP6). In addition a warning message is generated. The checking of the Attitude/Velocity reception rate is done in a cycle of 10 seconds active monitoring followed by a pause of 50 seconds. This implies that one minute might pass before a low reception rate event is reported.

- Attitude. Expected receiver frequency (Hz) (0=disable). This parameter defines the expected reception rate of the Attitude input. The default expected reception rate is 90 Hz, and the warning can be disabled by selecting 0.

If a reception rate below 90 % of expected rate occurs this is indicated by a warning indication (Yellow) in the Pitch, Roll and Heave items in the Numerical display. In addition a warning message is generated. This warning mechanism is used only for the currently active attitude sensor. Note that 100 Hz is the maximum reception rate that should be used for the Attitude sensors. Rates set higher might result in undetected low rate events. The checking of the Attitude reception rate is done based on a message received by SIS from the echo sounder containing the received attitude samples. The message arrives in SIS once every second or when it contains max 100 samples.

- Create DPT datagrams for each head. 1=enable. This parameter enables separate DPT datagrams to be generated for each sonar head. Default value is 0, select 1 to enable separate DPT datagrams. Applicable for EM 2040 dual RX and EM 2040C dual head.

Note

SIS needs to be restarted to effectuate any changes.

Startup options for system

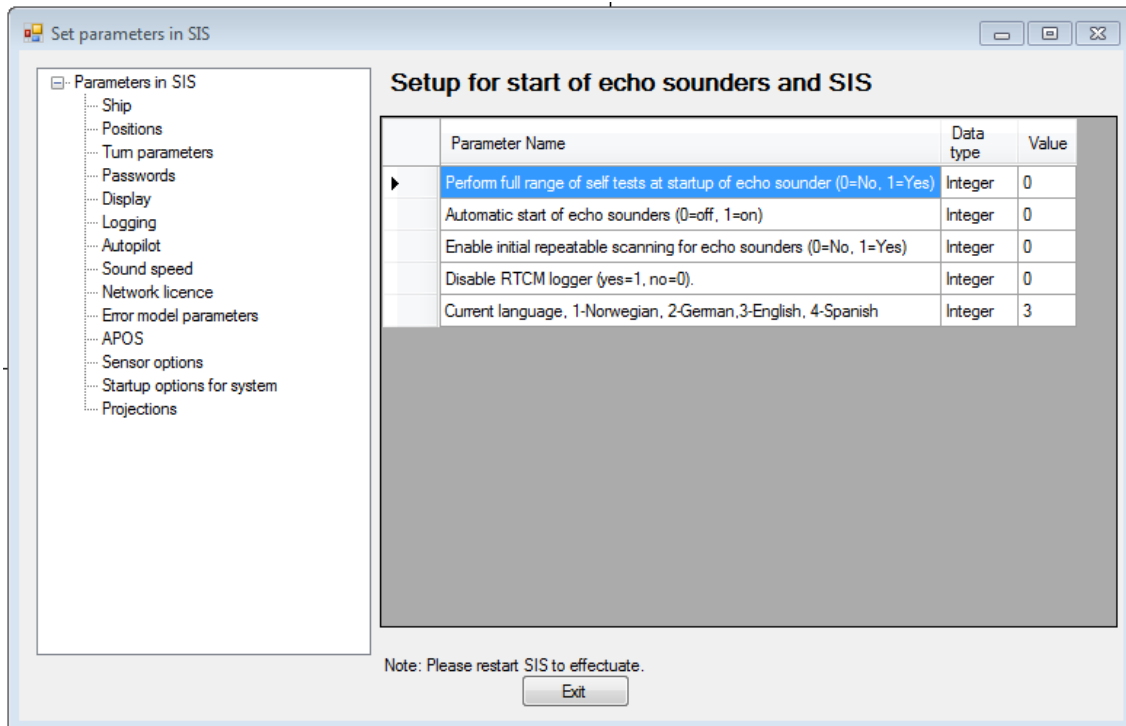

The **Startup option for system** parameters can be set as follows

- Perform full range of self test at start of echo sounder (0=No, 1=Yes). When enabled SIS will automatically run all defined BISTs (Built In Self Test) for the echo sounder when started. Default setting is off, i.e. BISTs are not run automatically.

When changed it is not necessary to restart SIS.

- Automatic start of echo sounders (0=off, 1=on). When enabled SIS will automatically start the echo sounder if no changes since last run is detected.
- Enable initial repeatable scanning for echo sounders (0=No, 1=Yes). Normal scanning operation at startup of SIS lasts for maximum 10 seconds, and is performed once. By enabling the initial repeatable scanning option SIS will continue scanning (5 sec on, 5 sec off) until an echo sounder is detected on the network. This feature is useful in the case where e.g. the SIS and the Processing Unit (PU) is turned on and started simultaneously. The PU has longer startup time than SIS, and by enabling this feature SIS will always detect the echo sounder.
- Disable RTCM logger (yes=1, no=0). The RTCM logger can be set to start only if desired. Select 1 to disable the RTCM logger. The default value is 0, RTCM logger enabled.

To disable the process from running, use SetParameters and set Disable RTCM logger to 1 in Startup options for system.

- Current language, 1-Norwegian, 2-German, 3-English, 4-Spanish. It is now possible to select a new language after initial SIS installation.

Note _____

Only the English and Norwegian language selections are complete. Selecting German or Spanish will result in a mixed language presentation where English is used when no native translation is available. This is most noticeable for the German language selection.

Also note that due to differences in word lengths, length of abbreviations etc. some SIS GUI elements will vary in size and layout depending on selected language.

Projections

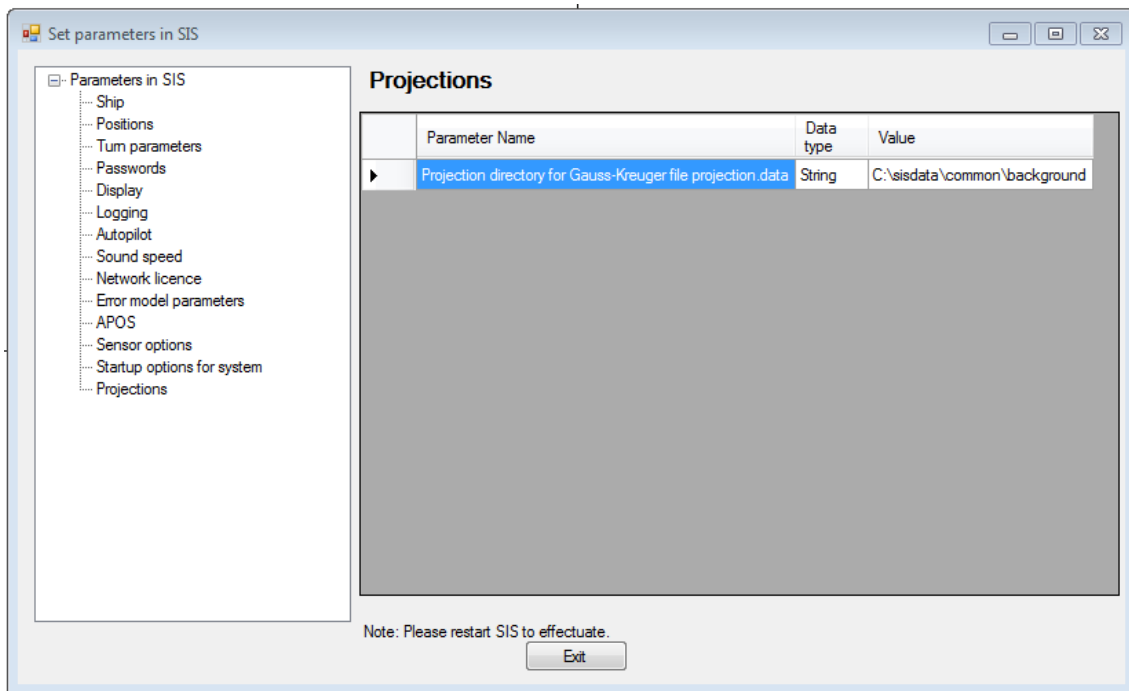

Gauß-Krüger projections for Germany and Austria can be selected as one of the standard projections in SIS. The file `projectionGK.data` is used to control the parameters for the datum transformation and transverse Mercator projection.

The following **projections** parameters can be set:

- Projection directory for Gauss-Kreuger file projection.data. This parameter defines the folder where the file `projectionGK.data` is stored.

File menu parameters

The **File** menu gives you the following choices:

- *Import/Export* on page 352
- *Export xyz file* on page 361
- *Remove survey* on page 362
- *Remove sounder* on page 362
- *Save settings* on page 363
- *Save settings as...* on page 363
- *Delete settings* on page 364
- *Set startup settings* on page 364
- *Export PU parameters...* on page 364
- *Import PU parameters...* on page 366
- *Set PU factory settings...* on page 367
- *Export user settings...* on page 368
- *Import user settings...* on page 369
- *Create CUBE grid* on page 369
- *Quit* on page 370

Related operational procedures

- *How to enter survey parameters* on page 114
- *How to export survey results after a survey* on page 207
- *How to create and use a GeoTIFF background image in the Geographical view* on page 166
- *How to exit the SIS software* on page 207
- *How to shut down the HWS* on page 208
- *How to shut down the Processor Unit (PU) or the Transceiver Unit* on page 208

Import/Export

The **Import/Export** dialogue is accessed from the **File** drop-down menu.

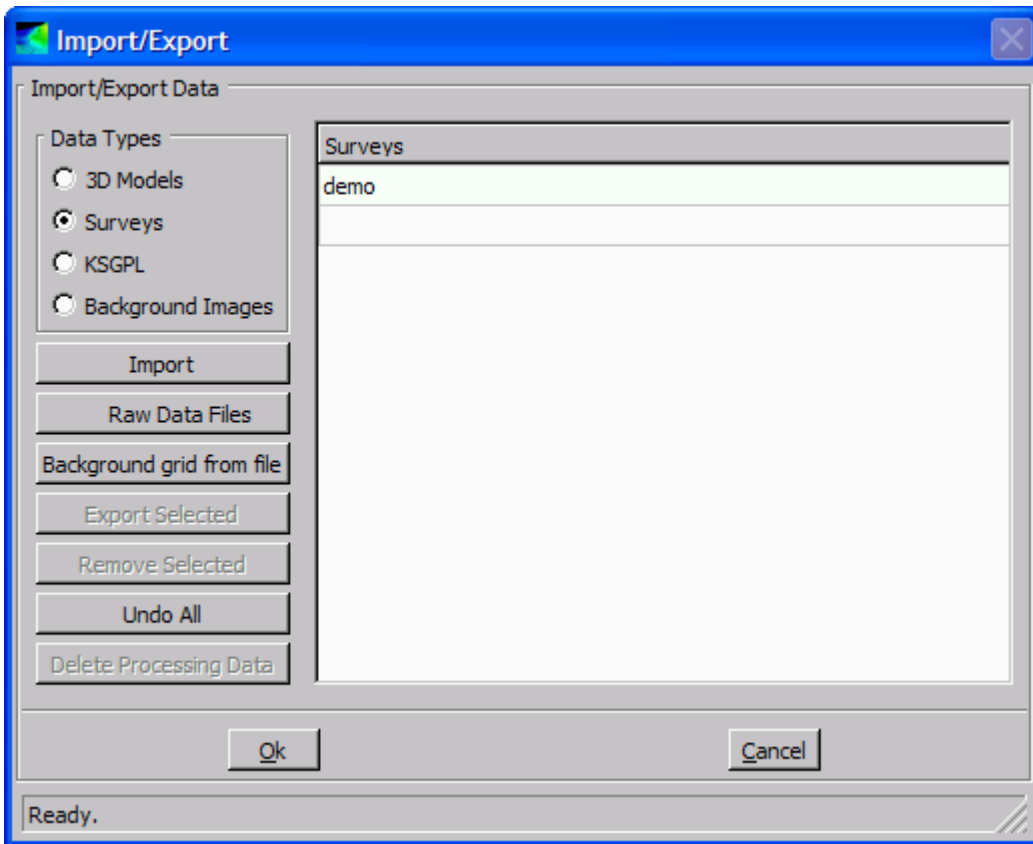

The following options are available in the Import/Export dialogue:

- **Data types:** The following data types can be imported:
 - 3D Models: You can import AutoCAD (*.dxf), Inventor (*.iv) or VRML (*.wrl)
 - Surveys: You can import either raw data files or already gridded data

Note

It is possible to reprocess data based on user defined rules if importing raw data files.

- KSGPL: Imports background KSGPL files (*.bgksgpl)
- Background Images: Imports a GeoTIFF background image
- **Import:** Press this button to import the selected data type
- **Raw Data Files:** Import raw data files
- **Background grid from file:** Create a background grid
- **Export Selected:** Press this button to export data (more details below)
- **Remove Selected:** Loaded or set to be loaded data can be unloaded by selecting the listed data items to the right and clicking this button

Note

*No files will be deleted on disk even if e.g. a survey has been reprocessed.
KSGPL background data can not be unloaded*

- **Undo All:** Undo actions

Note

No files will be deleted on disk even if e.g. a survey has been reprocessed

- **Delete Processing Data:** A gridded survey consist of many different file types. One of these types is called **Processing Files**. These files are used internally when creating a new grid or adding to an existing one. The files may use a lot of memory and hard disk space, but are generally not needed if the survey is closed and used for visualisation only. Thus, the Processing Data can be deleted. This is done by selecting the loaded surveys to be handled and pressing the **Delete Processing Data** button.
- Press **OK** to apply
- Press **Cancel** to abort

Data types

Depending on your selected **data type** pressing the **Import** button will launch the different import dialogue boxes:

- **3D Models:** Browse for the wanted 3D model file(s). Please wait some time to allow the 3D model to be processed. This may take a while depending on the size of the file. The imported 3D model(s) will be listed to the right if successfully processed/loaded.
- **Surveys (already gridded):** Browse for the directory where the already gridded survey is located. It is possible to select more than one survey for import, so multiple surveys can be imported in a single step.

Note

The grid may fail to be loaded if the GridEngine is not running or if a valid license is not present.

- **KSGPL:** Browse for a KSGPL background file.
- **Background Images:** Background images can be imported by selecting **Background Images** and pressing the **Import** button. This will launch a dialog box where you can import a **GeoTIFF** file. This is an ordinary TIFF image file with the geo-reference information in the TIFF file header, which also will be shown on the screen.
- **GeoTIFF Support:** Support for GeoTIFF files is summarized in the table below. ESRI world are not supported. Max file size is limited by available memory.

TIFF Tag Name	Support Values
PhotometricInterpretation	Grayscale, RGB, and Palette
Samples PerPixel	1, 2, 3 and 4
BitsPerSample	8

PlanarConfig	Chunky format (contiguous)
Compression	Uncompressed and LZW

Note

A background image can only be imported when a survey is loaded.

The Delete Processing Data and the Background Images will only be enabled if at least one of the given surveys is linked to Processing Data.

- Press **OK** to apply
- Press **Cancel** to abort

Raw Data files

Raw data files can be reprocessed/gridded with different settings.

- Import Raw Data Files field
 - **Survey name:** Give a name of the survey to be gridded.
 - **Existing Surveys:** Import raw data into a selectable existing survey. GridEngine parameters, projection, grid folder and user will be given by the existing survey and your raw data will be imported as defined by this.
 - **Select survey-template:** Select a survey templates defined in the **New Survey** or the **Survey Administration** frames.

Note

*Settings done in **Raw Data File** import dialog box will NOT update the selected survey template.*

- **Comment:** Write your own comment for the survey in the text field.
- **Raw data path:** Browse for the directory containing your raw data files to be processed. The files contained in this directory will be listed in the list box below. From this list raw data files can also be added one by one by pressing the **Add raw data files** button.

File	Size	Date
0_20070823_080517_simrad_echo.all	209418670	20070823 08:05:17
1_20070823_084340_simrad_echo.all	132801210	20070823 08:43:40
2_20070823_090334_simrad_echo.all	87129014	20070823 09:03:34
3_20070823_092135_simrad_echo.all	178632078	20070823 09:21:35
4_20070823_095135_simrad_echo.all	153245244	20070823 09:51:35
5_20070823_102135_simrad_echo.all	179939630	20070823 10:21:35
6_20070823_105135_simrad_echo.all	103307956	20070823 10:51:35
7_20070823_112351_simrad_echo.all	21530398	20070823 11:23:51
8_20070823_113022_simrad_echo.all	57965816	20070823 11:30:22

Add raw data files: 

- **Tide File:** Browse for tide file to be used, if any.
 - **Geoid File:** Browse for geoid file to be used, if any.
 - **Grid Folder:** Select where to store the survey files when imported and gridded.
 - **User:** Select a user from the combo box. To add new user(s) select **User handling** in the **Survey administration** frame.
 - **Projection:** Select a projection from the drop-down combo box. If a projection already has been set in the **New survey** frame, this field is greyed out.
- GridEngine Parameters field

Grid Engine Parameters

Depth variable:

Number of cells:

Cell size (m):

Processing parameters:

Put all depths into the grid

- **Depth variable:** Which depth value to be processed

If you are applying real time data cleaning, select what depth to use in the processing.

The real time data cleaning module will use the given depth plane to identify outliers in the data and remove them.

Note

We recommend that you set the real time data processing depth to either tide corrected depth, Z_b , or to geoid and RTK corrected depth, Z_v , in order to avoid unwanted depth rejections caused by natural variations such as the tide.

- **Number of cells:** Number of cells in one sub grid used by the GridEngine. The numbers of cells must be a power of 2 and between 16 and 512

- **Cell size (cm):** Size of each cell in the lowest (the most detailed) level of detail. Min = 10 cm, max = 15,000 cm.

Select resolution of your grid, i.e. number of cells and cell size, suitable for your depth and expected coverage.

Note _____

The grid resolution applies to displayed data only, the raw data is not affected.

The grid resolution can not be changed during the survey, and should therefore be carefully set to apply to the whole survey area.

If the cell size is set too large the resolution in your geographical view will be poorer than necessary. If you set the cell size too small you may experience that there are not sufficient data points in the cells to compute a valid depth value, and no depth value is displayed. Too small cell size may also overload the computer and give you delays in the real time display.

The following factors have influence on the selection of the cell number and cell size:

- * Depth
- * Achieved swath width (shown in numerical display)
- * Survey speed
- * Coverage area per beam (footprint)

The following rule of thumb have proven to be reasonable:

Normal resolution

- * Cell size = average swath width/100
- * Number of cells in processing grids: 64x64

High resolution

- * Cell size = average swath width/200
- * Number of cells in processing grids: 128x128

Example: If depth is 100 meters and sector coverage is set to $\pm 70^\circ$, the swath width is 550 meters. Cell size computed from above rule of thumb for may then be set to 5.5 meters for normal resolution and 2.8 meters for high resolution.

Note _____

The cell size settings applies to highest possible display resolution, i.e. LOD0.

- **Processing parameters:** By pressing this button you will be forwarded to the **Real Time Data Cleaning** menu.

The real time data cleaning uses rules, i.e. a set of parameters that controls the algorithms used in the real time processing of echo sounder data.

By default, the real time data cleaning is set off.

- Press **OK** to apply

- Press **Cancel** to abort

KSGPL: Browse for the wanted KSGPL background file.

Note

*One KSGPL file may override any other currently loaded KSGPL data.
KSGPL background data can not be unloaded*

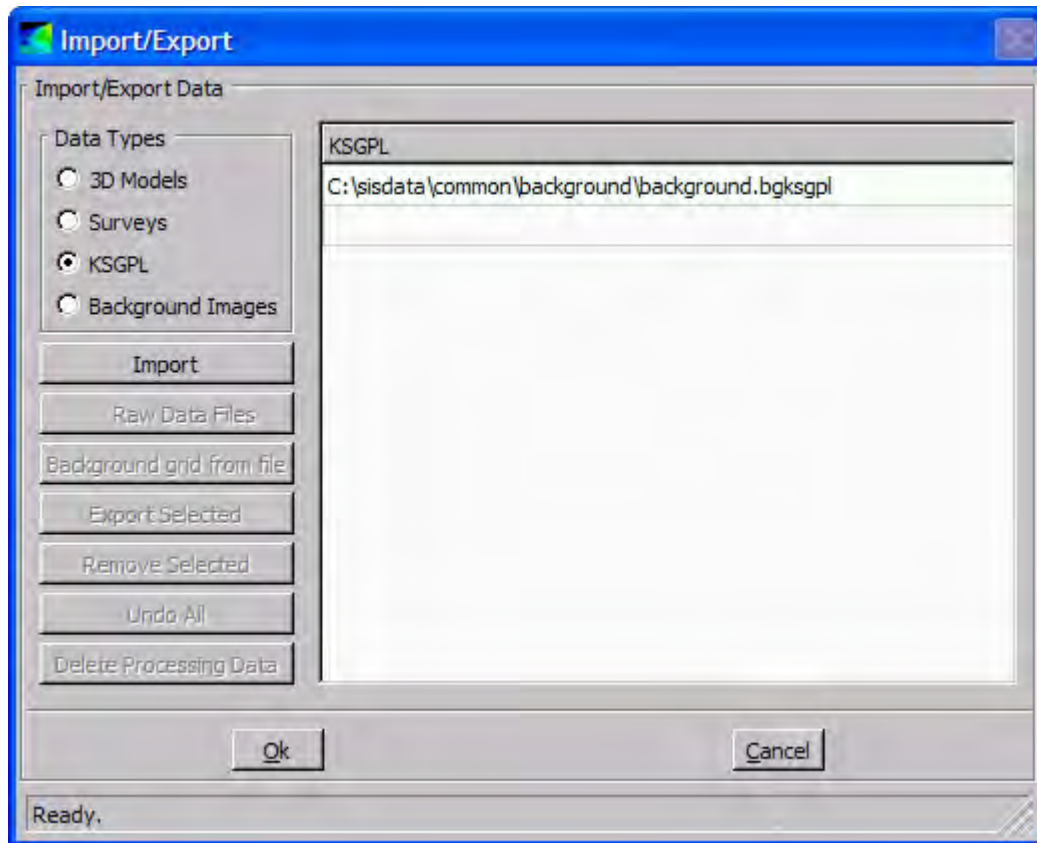

Background grid from file

Data generated from **File**→**Export xyz** or generated from **File**→**Import/Export**→**Export selected** can be used to create a background grid. Activating the **Background grid form file** menu, brings up a file selection box where you can choose a file with the extension **DAF.xyz**. A survey will be created from the file, using the projection and grid parameters from the current survey. When created, this survey will appear in the survey list, and later be loaded using the **Import** button. The name of the survey is created from the filename.

Note

The data in LoD 0 may appear sparse because of the resolution in the dataset. Normally LoD 1 displays the grid without “holes”.

Export of the selected data files

- 1 Select **File**→**Import/Export**

- 2 Select the survey data you want to export
- 3 Press the **Export...** button to launch the **Export Survey** dialogue box

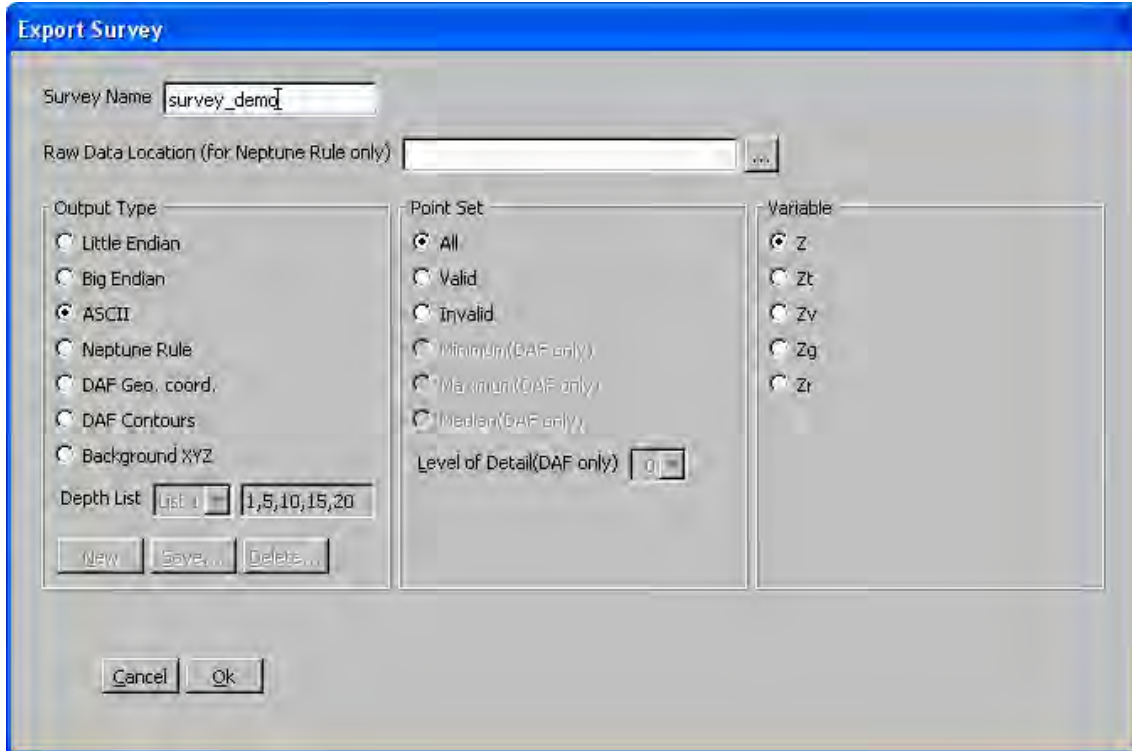

Survey name: Name of the survey to be exported.

Raw Data Location: This selection applies to export of a Neptune Rule file only. Browse for the disk location where the raw data files (.all files) are stored for the survey you want to export.

Output Type field: Select output file format to export the data to. The options are:

- **Little Endian:** Binary PC format file.
- **Big Endian:** Binary Unix format file.
- **ASCII:** Format details are written into the file itself.
- **Neptune Rule:** Create a rule file to be imported into Neptune post-processing. This setting overrides the **Point Set** and **Variable settings** described below.
- **DAF Geo. coord:** Creates a ASCII file with geographical coordinates in DAF format.
- **DAF Contours:** Creates at an ASCII file with contour lines in DAF format.
- **Background XYZ:** Creates an ASCII XYZ-file which can be used to create background grids.

Note

When exporting DAF formats the only available Point Set choices are Min, Max or Median.

Point Set field: Select whether you want **all**, **valid** or **invalid** points is to be exported.

Variable field: Select the Depth type to export. See the **Depth settings** in the **Geographical window** and the **Geoid** chapter.

Press **OK** to apply.

Press **Cancel** to abort.

DAF Export

When exporting either of the DAF formats, three additional Point Set variables are enabled. Select one of these to create the file. Level of Details (LoD) may also be set.

When selecting DAF Contours, you must select how to create the contours. Select from the **Depth List** or edit or create a new set.

For instance, you may choose to create contours at 1, 5,10 and 15 meters, every 2 meters, every 5 meters and so on. The predefined sets can be altered or new ones can be added by editing the right-most **Depth List** field and pressing **New** or **Save**. Pressing **Delete** removes the selected set.

DAF contours can be displayed in Neptune and other applications that supports the DAF format.

Related operational procedures

- *How to enter survey parameters* on page 114
- *How to import a Neptune grid to SIS* on page 159
- *How to export survey results after a survey* on page 207

Parameter references

- *Data cleaning* on page 317
- *Projection parameters* on page 269

Related topics

- *Export xyz file* on page 361
- *Export formats* on page 531
- *Geographical view* on page 57
- *Geoid* on page 515

Export xyz file

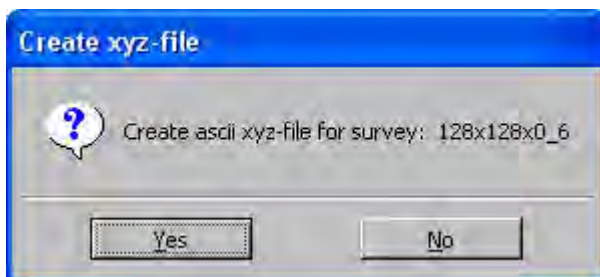

To export an ascii file of data from the current survey, press **File**→**Export xyz-file**.

The settings used to create the ascii xyz file are the same as used when exporting the survey.

The settings used are the **DAF Geo. Coordinates**, the **Point Set** is **Median** and the **LoD** (default setting is 0, the highest resolution). The variable **Z** is used by default. The latest value used, will be used by default.

The generated file will be placed in the grid directory of the survey (C:\sisdata\grids\Z is the variable used. The file is in ascii lat/long format, and can be zipped and transferred to other systems.

Remove survey

Surveys can be permanently deleted from the database. Logged data is not affected.

File→**Remove survey from database**

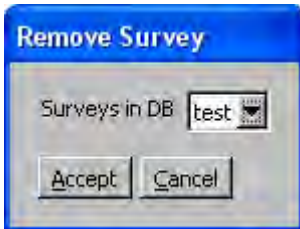

Remove sounder

All echo sounders on the network, detected by SIS during SIS start-up or **Rescan**, will be instantiated and permanently registered in the SIS database. To remove any obsolete or unwanted echo sounders from the database **File**→**Remove sounder from database** must be used.

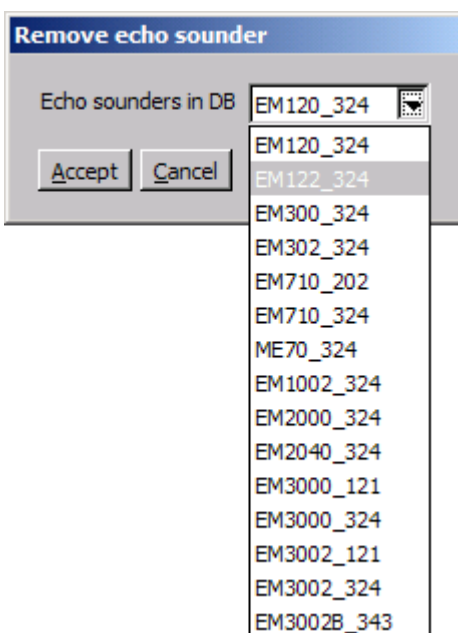

When selecting this item a new list is displayed containing all registered echo sounders that are eligible for deletion. When you make a selection from the list you will be asked for a confirmation before the echo sounder is deleted from the database.

Note

It is not allowed to remove the currently displayed (active) echo sounder or any started echo sounders, so these will not be included in the list.

Surveys, logged data or any stored PU parameter files etc. belonging to the removed echo sounder will not be deleted.

Save settings

Save Settings is accessed from the **File** drop-down menu. It will automatically save the current frame settings. If the current frame settings cannot be saved under the chosen name, you are prompted to use the **Save settings as...** option.

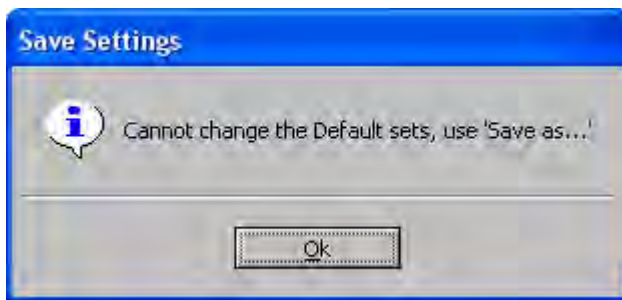

Save settings as...

The **Save Settings As...** is accessed from the **File** drop-down menu.

You can choose to save different frame setting combinations by giving them different names.

Press **Accept** to add the new frame setting.

Press **Cancel** to abort.

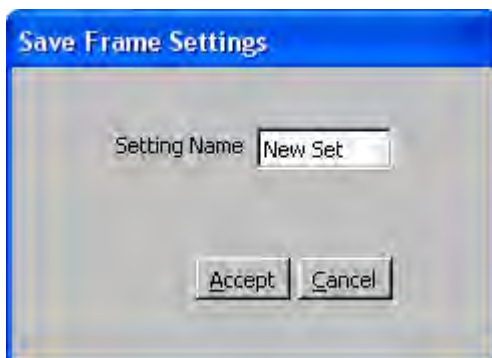

Delete settings

The **Delete Settings** is accessed from the **File** drop-down menu.

This is used to delete one of your predefined frame setting combinations.

Setting Name: Select the survey setting to be deleted.

Press **Accept** to add the new frame setting.

Press **Cancel** to abort.

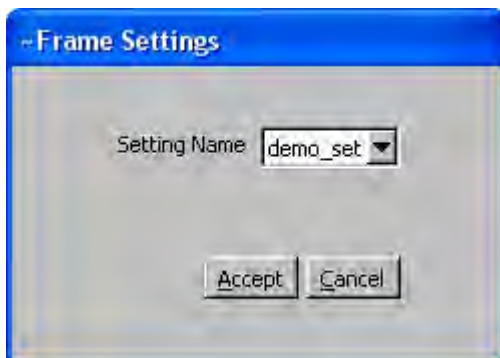

Set startup settings

You can choose the default start-up window settings:

File→**Set Startup Settings**.

When SIS starts up, the selected window set will be used.

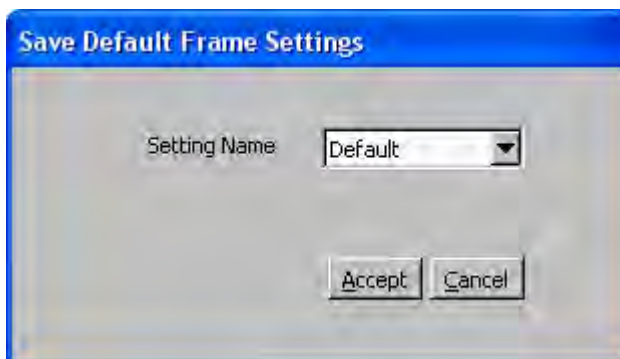

Export PU parameters...

Note

It is recommended that the parameters for an echo sounder is saved as soon as the initial configuration (i.e. installation and runtime parameters) has been completed and stored in the database.

Note

*Whenever the **OK** button is pressed from the **Installation parameters** frame a backup file containing current PU parameters is generated. The backup file can be Imported through **File**→**Import PU parameters...** The backup files are stored in `\sisdata\common\backup-settings` with the naming convention `Backup_<echo_sounder_name>_<serial number>_<YearMonthDay>_<HourMinuteSecond>.txt` e.g. `Backup_EM2040_402_20090430_105852.txt`.*

The **Export PU parameters...** operation is accessed from the **File** drop-down menu.

It is used to save the Installation and Runtime parameters for the current echo sounder to file in an ASCII readable format.

The file may later be imported whereby the saved settings are restored.

The file name and storage location can be specified in the standard **Save...** pop-up window displayed when **Export PU parameters...** is selected. A default storage location for such files is defined by SIS, but you are free to choose another location.

The default file extension is `.txt`, but any user defined extension is allowed.

When saving the file a **User comment** pop-up window will appear. You may enter any comments in this field. There are no limitations to amount of text. No graphical information or pictures may be included.

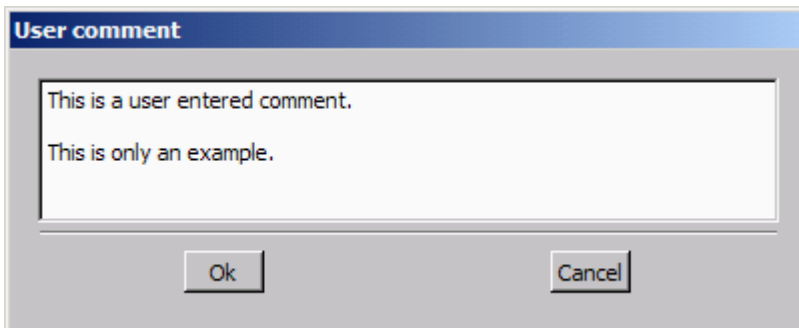

The **OK** button is used to complete and accept the entered text. The text is stored in the heading of in **User comments** brackets in the exported PU parameter file.

Note

The saved parameters file can be edited. However, this is not recommended and must only be performed by users with intimate knowledge of SIS.

Related topics

- *Current echo sounder* on page 36
- *Import PU parameters...* on page 366
- *Installation parameters* on page 274
- *Runtime parameters* on page 297

Import PU parameters...

The **Import PU parameters...** operation is accessed from the **File** drop-down menu.

It is used to read a previously saved parameters file for a specific echo sounder and restore the parameter settings for this echo sounder to the same status as when the file was saved.

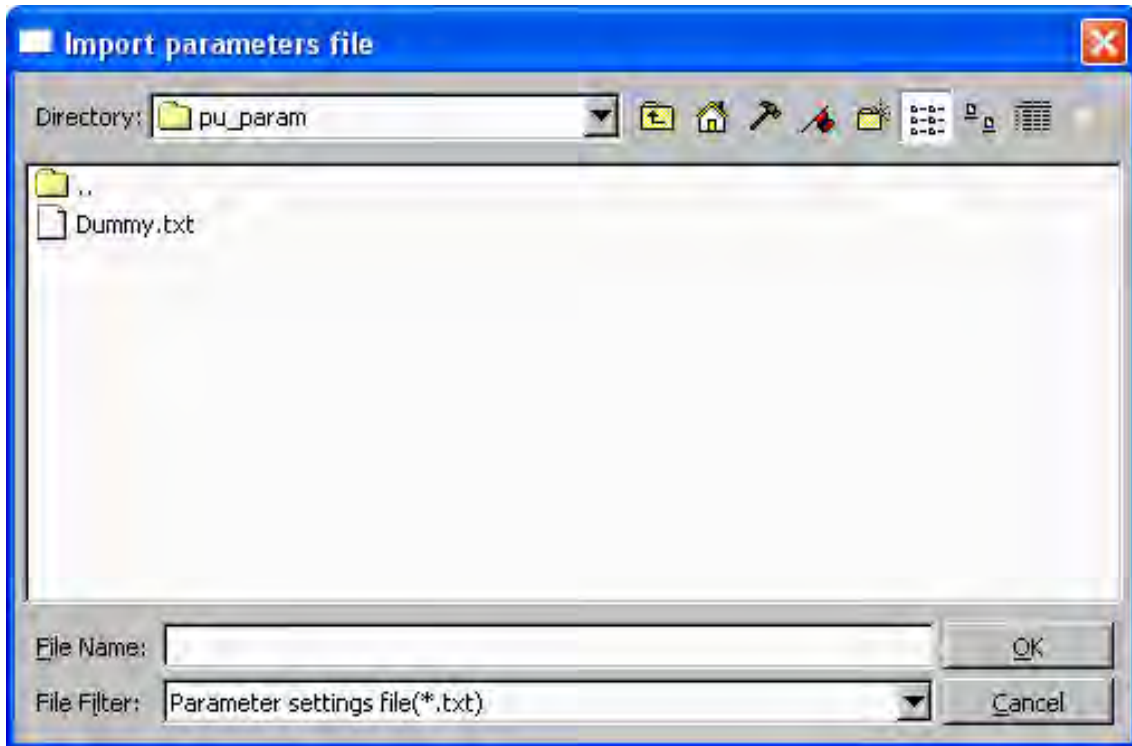

The import operation can be performed without consideration of which echo sounder is currently set as active or whether the relevant echo sounder is started or even detected on the network.

Note

The echo sounder will not be automatically updated with imported settings. Only the database (SISDB) will be updated. It is therefore necessary to manually initiate an update of the echo sounder (PU) by starting it (if not previously started) or by using the Installation Parameters - or the Runtime parameters frame.

The file name and storage location of the PU parameter file can be specified in the pop-up window displayed when Import PU parameters is selected.

The Import PU parameters operation is typically used to avoid having to re-enter all set-up parameters manually after reinstalling SIS and the database.

When importing PU parameters a pop-up dialog box will be used to allow you to specify another serial number to replace the serial number in the imported file. This will effectively allow you to copy a parameter setup from one configuration to another e.g. when replacing/changing a main sonar head.

Note

Remember to save the parameters if changing serial number.

OK button indication

When importing PU parameters the **OK** button in the **Installation parameter** frame is set to yellow to indicate that the PU must be updated with the new settings.

The **OK** is only set yellow when the selected active echo sounder is the same as the echo sounder that the PU parameters are imported for.

Related topics

- *Current echo sounder* on page 36
- *Export PU parameters...* on page 364
- *Installation parameters* on page 274
- *Runtime parameters* on page 297

Set PU factory settings...

Currently selected echo sounder (PU) can be reset/restored to its original factory default parameter settings by selecting **File**→**Set PU factory settings...** The **Installation** and **Runtime** parameters are included in this action.

Note

*To avoid loss of your original parameter values, you may export current parameters to file by selecting **File**→**Export PU parameters...***

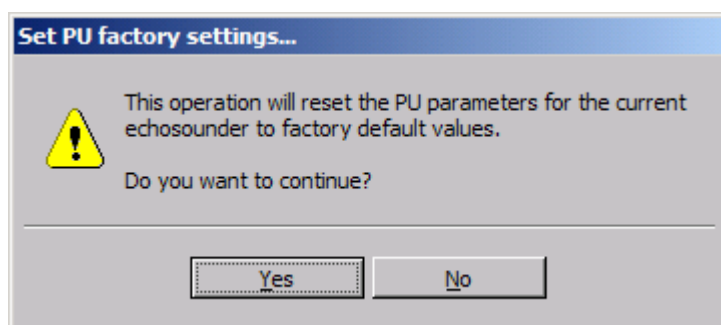

If you select **Yes** to continue the action, another pop-up is displayed asking whether you would like to change the serial number (e.g. for preparing the setup of a future system). You may also cancel the operation at this stage by pressing the **Cancel** button, or loading the factory settings by pressing either the **Yes** or **No** button.

The factory default parameter values are defined independently for each type of multibeam echo sounder. The parameters are stored in a file of the same format as used by **Export PU parameters...** and **Import PU parameters...** functions.

Note

*In order to effectuate the reset parameters for the selected echo sounder, the parameters must be transferred to the PU. The parameters are transferred only when the echo sounder is started or when the OK button is pressed in the Installation window. The **OK** button in the **Installation parameters** frame will be set to yellow until pressed.*

Related topics

- *Export PU parameters...* on page 364
- *Import PU parameters...* on page 366

Export user settings...

The **Export User settings...** operation is accessed from the **File** drop-down menu.

It is used to save current database settings for later retrieval.

The following **Export selections** can be made:

- **User parameters:** Stores the entries set in the **Set Parameter** menu
- **Datagram subscription:** Stores a list of the datagrams subscribed to in current database settings
- **Survey template:** Stores the survey definition
- **Projections:** Stores the name and definitions for selected projection
- **Frame settings:** Stores current frame setting definitions

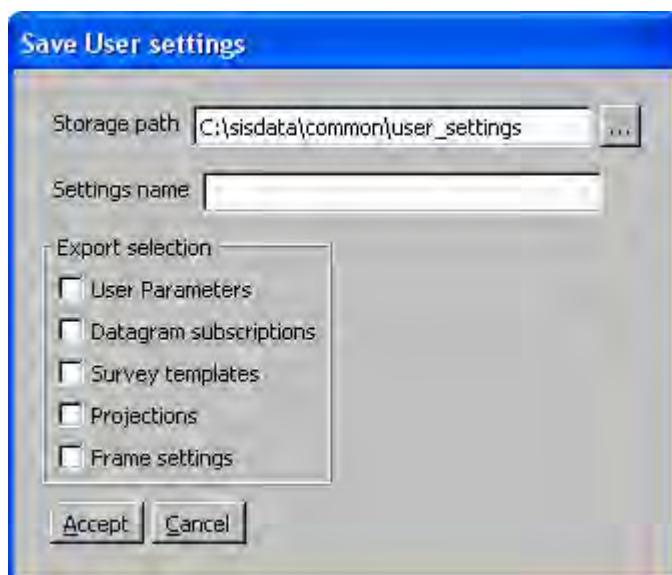

Related topics

- *SIS parameters – Set parameters* on page 333
- *Frame toolbars parameters* on page 209
- *Survey parameters* on page 263
- *Projection and datum parameters* on page 384

Import user settings...

The **Import User settings...** operation is accessed from the **File** menu.

It is used to restore earlier exported database settings.

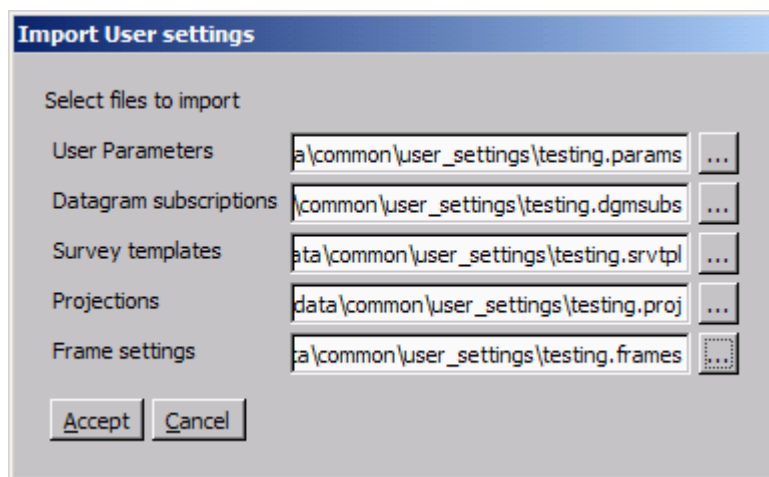

The following **Import selections** can be made:

- **User parameters:** Restores entries set in the **Set Parameter** menu
- **Datagram subscription:** Restores the datagrams subscribed to
- **Survey template:** Restores survey definition
- **Projections:** Restores projection
- **Frame settings:** Restores frame settings

Related topics

- *SIS parameters – Set parameters* on page 333
- *Frame toolbars parameters* on page 209
- *Survey parameters* on page 263
- *Projection and datum parameters* on page 384

Create CUBE grid

When logging is completed, a **CUBE grid** may be generated:

File→**Create CUBE grid**.

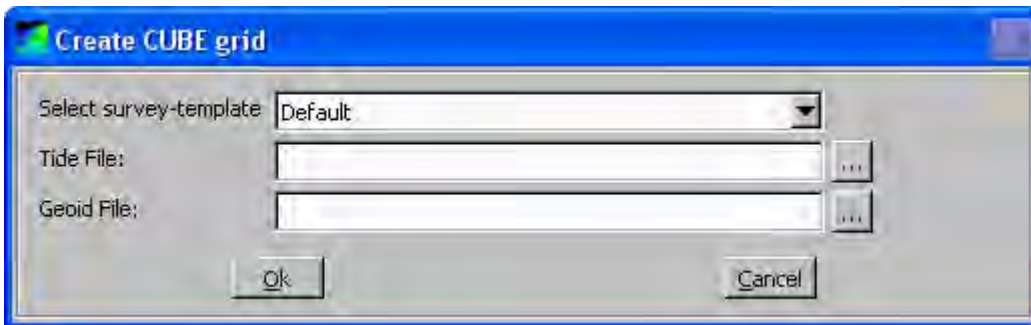

The same survey template from which the current survey was created, is set as default. The first tide and geoid file, found in the raw data folder, is displayed in the menu. The buttons at the right hand side can be used to browse for other tide and geoid files.

Pressing the OK button starts the processing, and a progress box appears. The whole SIS application is locked while the CUBE grid is generated and as long the **Create CUBE Grid** box is active. The **Create CUBE Grid** box will be visible for a while, after the SIS progress box disappear, to complete the necessary calculations.

If the CUBE grid is to be shown, SIS must be set to CUBE mode. Start **Set Parameters** from the **Tools**→**Custom** menu, select **Logging** and set the data cleaning method to CUBE. SIS has to be restarted, and no echo sounders have to be started before the grid is imported to SIS.

Parameter references

- *Logging* on page 341

Related topics

- *CUBE* on page 464

Quit

Quit is accessed from the **File** drop-down menu.

This will shut down the SIS program without any further confirmation of your choice.

The SIS program can also be shut down by using the **Close** button on the right hand side of the SIS title and info bar (i.e. upper right corner of the SIS application window).

Note

Closing down may take some seconds. Do not try to restart SIS until the SIS application window has disappeared.

Related operational procedures

- *How to exit the SIS software* on page 207
- *How to shut down the HWS* on page 208
- *How to shut down the Processor Unit (PU) or the Transceiver Unit* on page 208

Tools menu parameters

The **Tools** drop-down menu gives you the following choices:

- *External sensors* on page 371
- *Instrument combinations* on page 377
- *Remove instruments* on page 378
- *C-MAP – Licence administration* on page 379
- *AutoCalib Wizard* on page 380
- *SeaCal results* on page 381
- *Extract IFF* on page 381
- *Custom menu* on page 106

Related operational procedures

- *How to save data* on page 169
- *How to define a new projection and datum transformation* on page 122
- *How to enter the waterline for a single beam system* on page 139
- *How to collect the sound velocity profile* on page 141
- *How to convert your sound velocity profile to SIS format* on page 143
- *How to modify and load a sound speed profile into SIS* on page 151
- *How to run the PU simulator* on page 203

External sensors

External sensors is accessed from the **Tools** menu.

This is where you define the interfaces to your external sensors that are attached directly to the Hydrographic Work Station (HWS) computer or sensors sending their data on Ethernet to the HWS computer.

Note _____

*Interfaces to external sensors that are attached to the Processing Unit (PU) are defined in the **Installation parameters**.*

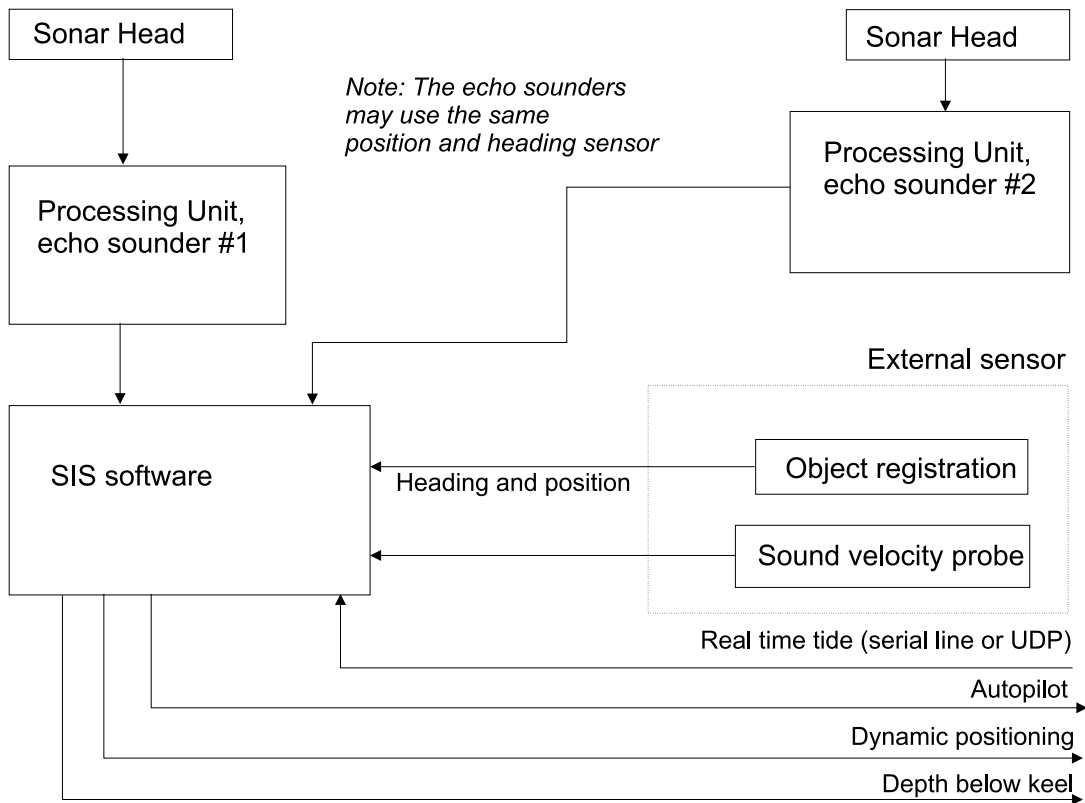
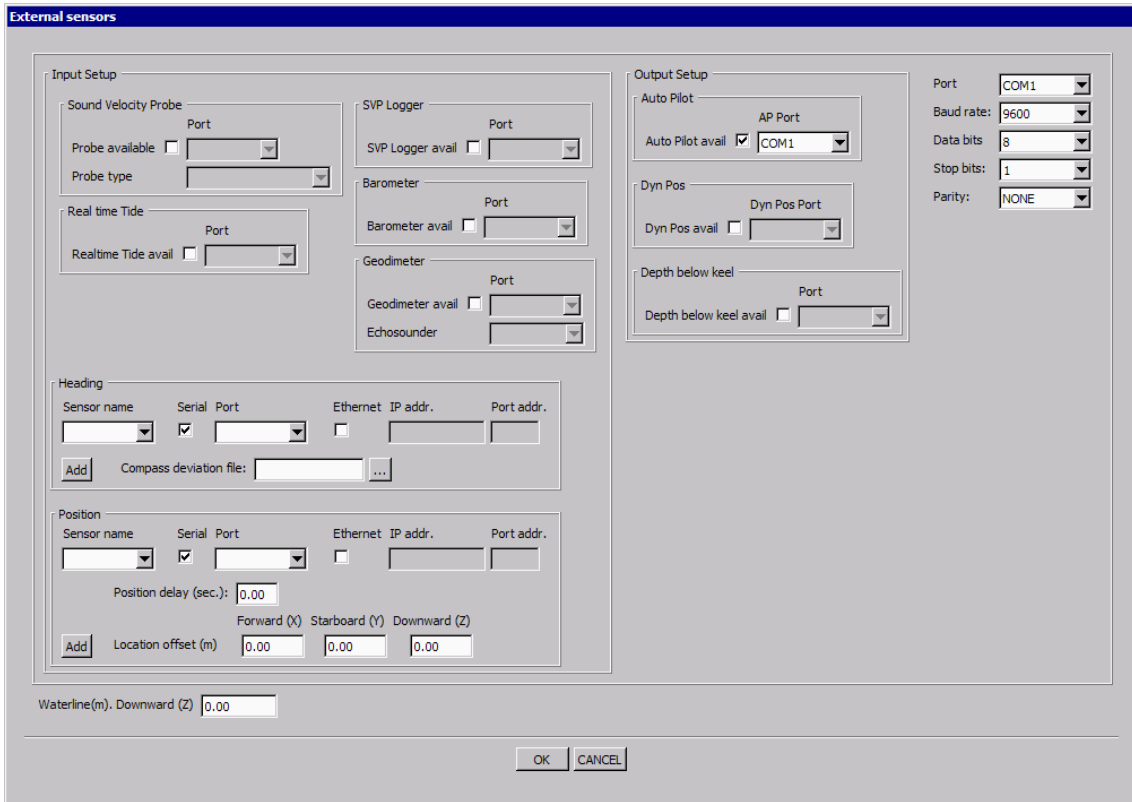

(cd22019)

Input setup

- **Sound Velocity Probe type**

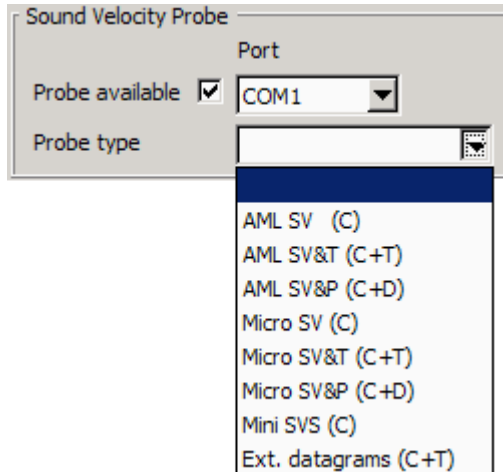

This is where you interface a sound velocity probe that is to be instantaneously read by SIS, typically a sound velocity probe installed at transducer depth. The following probes are supported:

- AML SV (C) - only sound velocity
- AML SV&T (C+T) - sound velocity and temperature
- AML SV&P (C+P) - sound velocity and pressure (pressure not significant)
- AML Micro SV (C)
- AML Micro SV&T
- AML Micro SV&P
- Valeport Mini SVS
- Ext. datagrams (C+T) - sound velocity and temperature

See format description in *Sound speed profile formats* on page 544

Sound speed sample frequency rate

The sample rate expected from the sound velocity sensors (SV, SV&T, SV&P) is 10 Hz. The sample rate of the external datagrams is 1 Hz.

These rates are used in the sound speed filtering. For more details on filtering see the **Sound Speed** entry in the **Runtime parameters** setup.

- **Real time tide:**

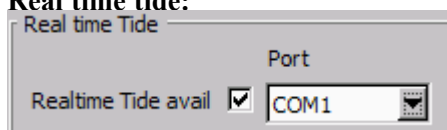

SIS can receive real time tide information on serial lines. Select **Realtime Tide available** and set the communication parameters for the selected line.

- **Heading parameters:** Applies in situations where you are interfacing the heading sensor directly to the HWS. Normally, you will interface the heading sensor to the PU, but in rear cases where you are running SIS without any multibeam echo sounder PU, you may use this option.

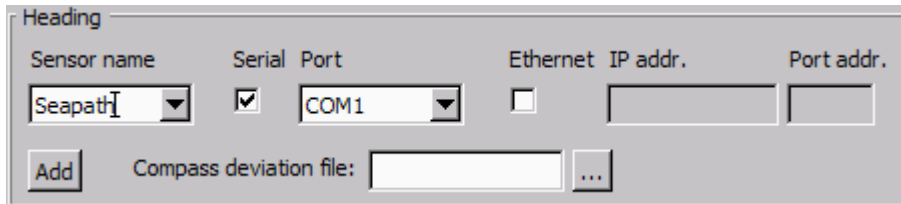

- **Sensor name:** Display name
 - **Serial/Port:** When serial interface is enabled the com port number must be set
 - **Ethernet/IP address/port:** When ethernet interface is enables IP address and local port number must be set
 - **Add:** Must be pressed for each system you configure
 - **Compass deviation file:** Use the browse button (three dots) to find the desired file.
- **Position parameters:** Applies in situations where you are interfacing the positioning sensor directly to the HWS. Normally, you will interface the positioning sensor to the PU, but in rear cases where you are running SIS without any multibeam echo sounder PU, you may use this option.

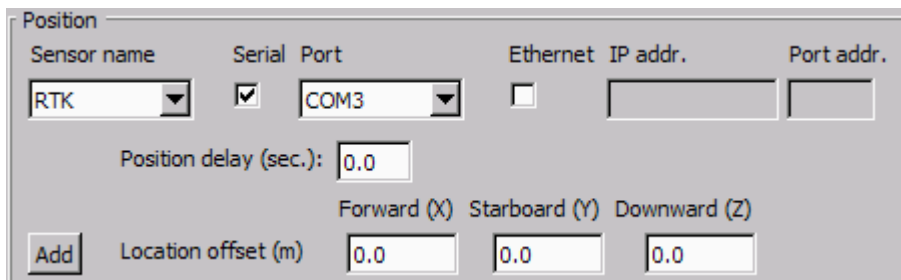

- **Sensor name:** Display name
- **Serial/Port:** When serial interface is enabled the com port number must be set
- **Ethernet/IP address/port:** When ethernet interface is enables IP address and local port number must be set
- **Position delay (sec):** Enter any known position delay.

The accuracy of the position sensor is vital for the data accuracy, and it is therefore important that the relative timing of vessel position data and system depth data is correct. To define the duration of life of the positioning system input data, you can enter a position delay.

A position delay is required if the position that is output on the port applies to an observation that was done a significant number of seconds ago. The position delay may be significant for systems where the internal computation and processing of the position takes time.

- **Add:** Must be pressed for each system you configure

- **Location offset (m):** Use the text fields to enter the location of the GPS antenna relative to the vessel's reference point.

Caution

The positioning system may have internal offset parameters set. Make sure that the antenna offsets are not applied both in the position system and in SIS.

- **SVP Logger**

Selects a serial line and sets the parameters. The SVP Logger is started from the SVP editor..

- **Barometer**

Set if barometer input is available and select HWS input port (serial line).

- **Geodimeter**

This setting applies if a Geodimeter position system is being used. Set whether a Geodimeter is available, select HWS input port (serial line) and select the echo sounder where the position input is to be sent to.

Output setup

- **Auto Pilot parameters:**

Select **Auto Pilot available** if you want data to be sent to the auto pilot. Choose a serial line from the combo box.

Enabling or disabling of NMEA APB output is done in the **Show/Hide** menu of the **Helmsman display**. See *Helmsman display – Show/hide* on page 237

- **Dyn Pos parameters:**

Select **Dyn. Pos. available** if you want data to be sent to the dynamic positioning system. Choose a serial line from the combo box.

- **Depth below keel:**

The **Centre depth output** is always sent as a NMEA DPT datagram on UDP to port number 4310. The NMEA depth output from SIS is coded. The two aa's in the string \$aaDPT are set according to sounder type, see table below.

Refer to *Depth under keel output format* on page 534 for description of the format.

If depth below keel is selected in the External sensor user interface the NMEA datagram is sent out to the selected serial line.

Echo Sounder Model	NMEA String
EM 2000	\$KADPT
EM 3000	\$KBDPT
EM 3002	\$KCDPT
EM 1002	\$KDDPT
ME70/BO	\$KJDPT
EM 710	\$KEDPT
EM 300	\$KFDPT
EM 302	\$KHDPT
EM 120	\$KGDPT
EM 122	\$KIDPT

Other parameters

- **Port:** Choose the port you want to set communication parameters for
- **Baud rate:** 1200, 2400, 4800, 9600 or 19200
- **Data bits:** 7 or 8
- **Stop bits:** 1 or 2
- **Parity:** None, Odd or Even.

Waterline

Enter the vessel's waterline vertical location (in normal trim) in the vessel's reference coordinate system. It is recommended to use an average of two measurements; one on each side of the vessel. The measurement must be made at the same alongship location as the physical location of the motion sensor.

Note

If the vessel's displacement or trim changes during a survey, the Waterline value must be updated accordingly.

Related operational procedures

- *How to setup the input from external sensors* on page 137
- *How to setup the output to external sensors* on page 139
- *How to enter the waterline for a single beam system* on page 139
- *How to use SVP Logger* on page 144

Parameter references

- *Sound speed for EM 2040* on page 305

Related topics

- *SVP Editor* on page 395
- *Barometer input* on page 574
- *External datagram (C+T) format* on page 550
- *Helmsman display view* on page 70
- *Depth under keel output format* on page 534

Instrument combinations

Instrument combinations is accessed from the **Tools** menu.

Through the **Instrument combination** you may add interfaces to equipment that does not communicate through the echo sounder PU and does not broadcast on the Ethernet.

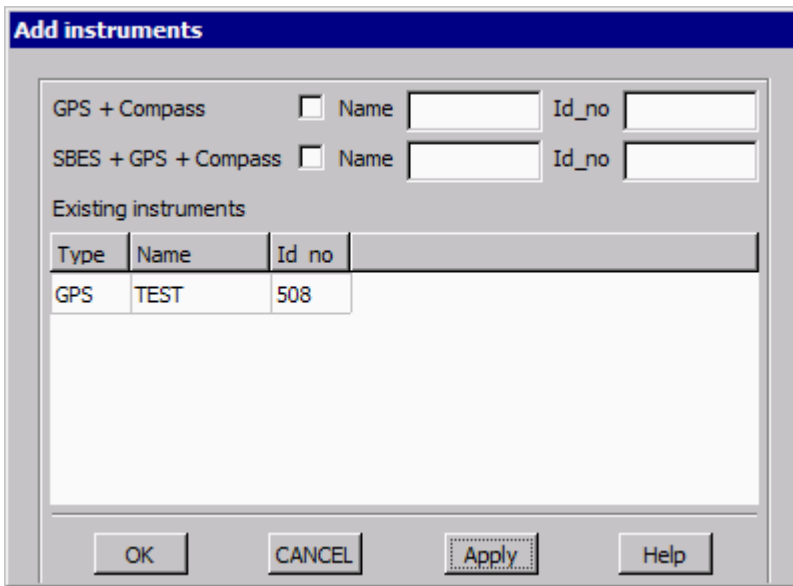

The equipment can be GPS, compass or single beam echo sounder (SBES) type equipment.

You have to give the instrument an ID number. This number must be unique for each type of equipment. The ID number is treated the same way as the serial number for equipment with a PU (Processing Unit).

After the instruments are registered they will appear in the **Not Started** combo box and the **Current echo sounder** combo box on the main toolbar.

Add instrument parameters

GPS + Compass: Give the new instrument a name and an ID number to GPS and compass type equipment

SBES + GPS + Compass: Give the new instrument a name and an ID number to SBES, GPS and compass type equipment

Existing instruments: A list of the instruments that have been defined.

Related topics

- *Remove instruments* on page 378
- *Echo sounder – Not started list* on page 35
- *Current echo sounder* on page 36

Remove instruments

The **Remove Instruments** is accessed from the **Tools** menu.

Select the instrument you want to remove, and press **OK**.

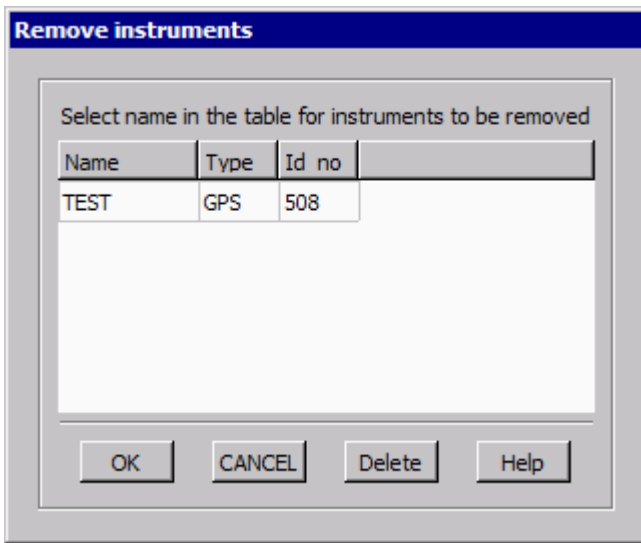

C-MAP – Licence administration

Note

This menu choice will only be visible if C-Map is installed.

C-MAP is accessed from the **Tools** menu and contains the following administrative sub menus:

- **LicenceAdm** – giving you the opportunity to administrate the C-MAP licence in SIS
- **GDBAdmin** – for administration of the C-MAP database
- **Update charts** – administration of C-MAP chart updates

LicenceAdm

Note

C-MAP licensing is not included in standard SIS delivery and must be ordered separately.

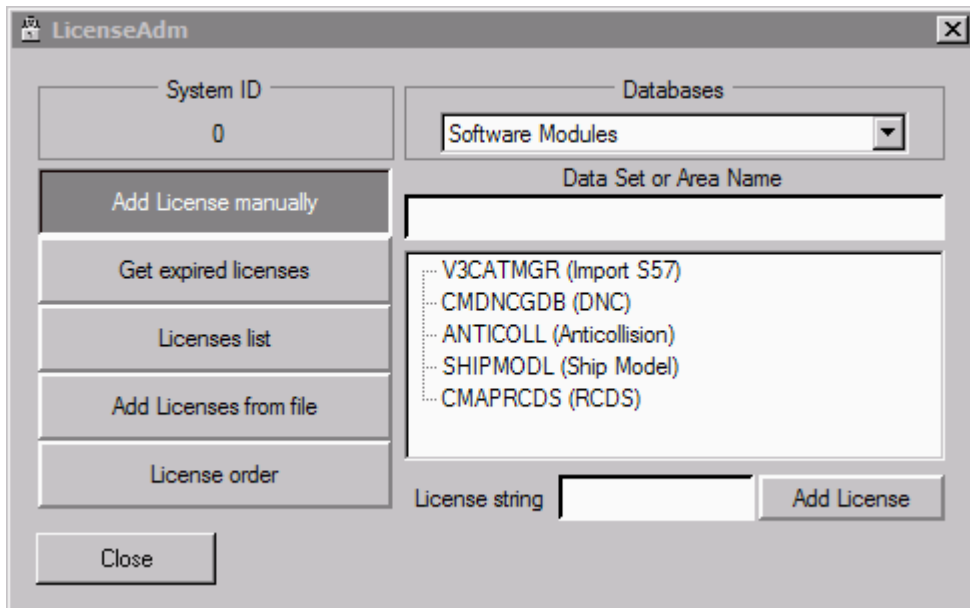

The following options for C-MAP Licence Administration are available:

- **Add License manually:** You may enter your license manually by entering the alphanumeric string in the **License string** text field. The license string is issued by C-MAP Norway.
- **Get expired licenses:** Press this button to see whether earlier versions of C-MAP have been installed and when the subscription date exceeded.
May be of interest for C-MAP trouble shooting.
- **License list:** Gives you an overview of the C-MAP licenses, i.e. zones, that your system subscribes to.
- **Add license from file:** You will normally have received you C-MAP license both as an alphanumeric string and contained in a file. The file is by default named **PASSWORD.USR**. Browse for this file and press **OK** to apply.
- **License order:** This view gives you an overview of what licenses your system subscribes to.

Related topics

- *C-MAP CM-93/3* on page 443
- *C-MAP detail level* on page 41
- *Geographical – C-MAP manipulation mode* on page 225

AutoCalib Wizard

Before running the **AutoCalib Wizard**, ensure that the survey you want to run the calibration on is loaded, and that the raw files are available.

From the **Tools** menu, select **AutoCalib Wizard...** to start the calibration process. The **AutoCalib Wizard window** will appear, and a further set of dialogue boxes will be available. Respond to them according to how you want to run the calibration.



After the last dialogue box has been displayed, the calibration process will start in the background. You may continue working while the process is running. When the process is finished you will be prompted to open the result file and inspect the result. You can also open the file and inspect the result later by selecting **Tools**→**SeaCal Results**. (The SeaCal program is used by AutoCalib.) The results may be applied to the echo sounder's installation parameters or saved to a file for later use. If you want to apply the result, you must open the **Installation Frame**, and press **OK** to activate the result, as when storing the manual calibration values.

Related topics

- *Calibration parameters* on page 260
- *Seacal auto calibration* on page 261
- *SeaCal results* on page 381
- *SeaCal* on page 409

SeaCal results

The **SeaCal Results** is accessed from the **Tools** menu.

Use this option to browse for and open SeaCal result files (*.res).

Related topics

- *Calibration parameters* on page 260
- *Seacal auto calibration* on page 261
- *AutoCalib Wizard* on page 380
- *SeaCal* on page 409

Extract IFF

The **Extract IFF** is accessed from the **Tools** menu. From this menu, **Position**→**All** and **Position**→**New** can be chosen.

Position→**All** will create **Intermediate File Format** files of all position datagrams in the survey lines. **Position**→**New** will extract positions from new files not previously processed.

The positions can be colour-coded by the quality indicator in the GGA datagram. The quality factor will identify where the position quality is based on 2D or 3D GPS position determination, i.e. where a valid height is computed or not.

Note

Logging must be Off for the IFF functionality to be activated

The quality factor of the positions can be view in the **Geographical** view. **Processed positions** must be selected from the **Option** button in the Geographical view, see *Options* on page 211.

Configure...

The **Configure...** item is accessed from the **Custom** sub-menu found in the **Tools** main menu.

The Configure dialogue box is used to manage existing applications in the **Custom** sub-menu. It is possible to add, hide or delete applications, or change the sequence in which they appear in the Custom sub-menu. Note that it is not possible to delete any of the factory defined applications.

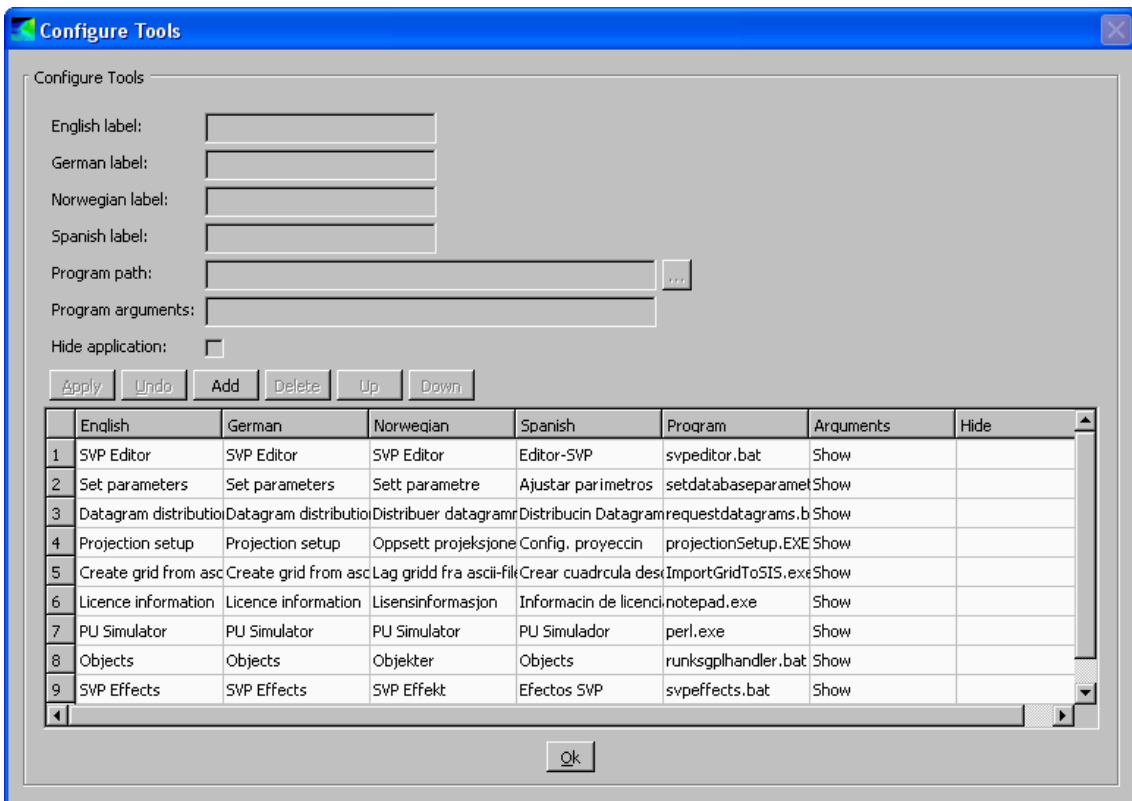

A new application is added by pressing the **Add** button in the dialogue box. Fill in all text fields marked in yellow. Press the **Apply** button to add the new application to the Custom sub-menu.

Program arguments can be added, e.g. a text file if the application is a text editor.

Click the **Hide** application box to hide a console application when starting SIS. The application will then only be visible in the Task Manager.

Press the **OK** button to store changes.

Press **Esc** to cancel.

Related topics

- *Custom menu* on page 106

Projection and datum parameters

When selecting **Tools**→**Custom**→**Projection setup** the Projections window opens.

The **Projection** setup must be used to define the following geodetic parameters:

- The datum your input positions refer to
- The datum you want your output positions to refer to
- The datum transformation parameters to apply to the input positions
- The projection for the plane coordinates (map coordinates)

Note

*If your projection and datum transformation is already defined in SIS, you do not have to enter the Projection setup. The correct projection can be directly selected through the **Survey Administration** or the **New Survey setup** pages.*

This **Projection** window contains two tabs:

- The **Define projections** tab is where you define the datum transformation and projection:
 - Projection (and datum transformation) may be selected from a **PROJ.4** file, or
 - Projection (and datum transformation) may be selected from the SIS database, or
 - You may enter your datum transformation and projection parameters manually
- The **Test selected projection** tab allows you to test the selected datum transformation and projection.

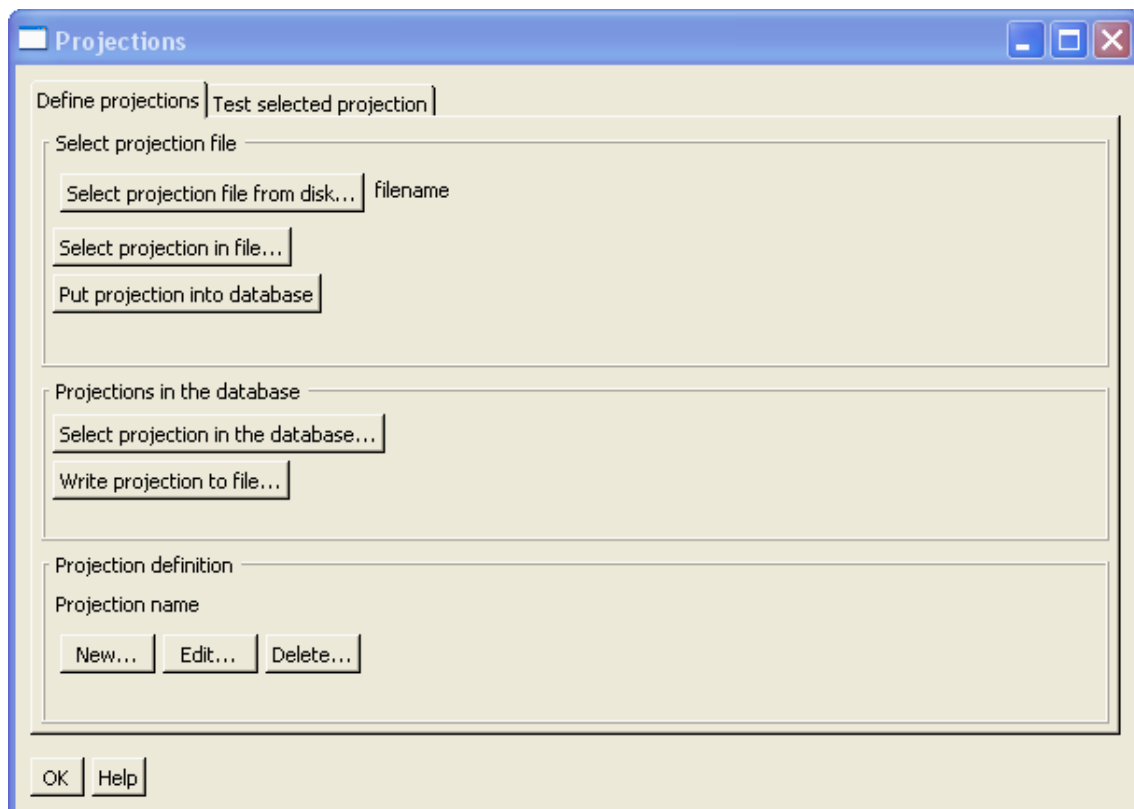

Select projection file

- **Select projection file from disk** opens a file selection box where you can select files in PROJ.4 format.

Note

PROJ.4 format is a generic format for definition of projection of geographical coordinates to plane coordinates. The PROJ.4 format may also contain datum transformation parameters.

- **Select projection in file** is then used to select the projection in the selected file. The name of the selected projection appears below.
- **Put projection into database**; a projection from the file is inserted into the database. The database tables are updated. It is not possible to change a projection if it is used by any surveys unless the user specifies it.

Projections in the database

- **Select projection in the database**; you can also select a projection from the database. It is not allowed to change a projection used by a survey unless you specify it.
- **Write projection to file**; selected projection is stored to file in PROJ.4 format.

Projection definition

You may input, edit or delete your own definitions of projection and datum transformation parameters by using the **New**, **Edit** and **Delete** buttons.

Test selected projection

Test selected projection allow you to test the selected projection. You can choose the format of the geographical coordinates to decimal degrees, decimal minutes or decimal seconds. You can then input geographical coordinates and press **Calculate** in that window to see the projection coordinates in the window below, or vice versa.

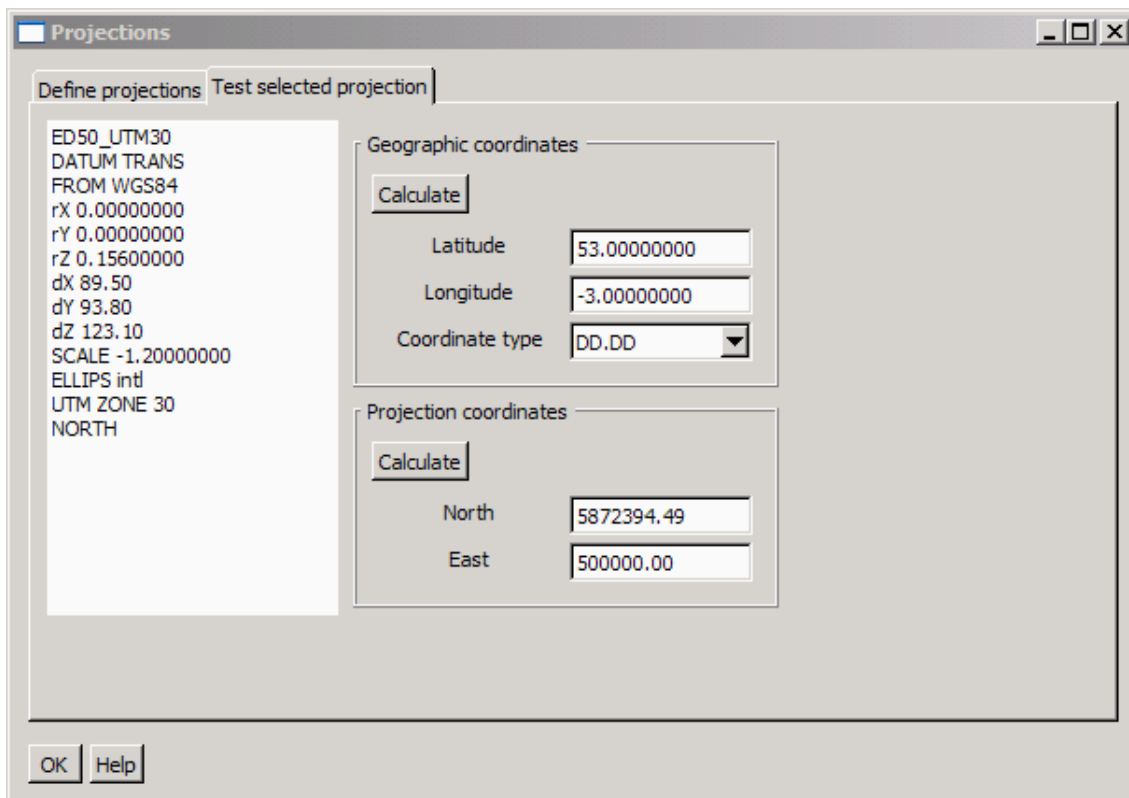

Available ellipsoid definitions in SIS

Ellipsoid name	Major axis (a)	Reverse flattening (rf) / Minor axis (b)	Description
MERIT	a=6378137.0	rf=298.257	MERIT 1983
SGS85	a=6378136.0	rf=298.257	Soviet Geodetic System 85
GRS80	a=6378137.0	rf=298.257222101	GRS 1980 (IUGG, 1980)
IAU76	a=6378140.0	rf=298.257	IAU 1976
airy	a=6377563.396	b=6356256.910	Airy 1830
APL4.9	a=6378137.0	rf=298.25	Appl. Physics. 1965
NWL9D	a=6378145.0	rf=298.25	Naval Weapons Lab., 1965
mod_airy	a=6377340.189	b=6356034.446	Modified Airy
andrae	a=6377104.43	rf=300.0	Andrae 1876 (Den., lclnd.)
aust_SA	a=6378160.0	rf=298.25	Australian Natl & S. Amer. 1969

Ellipsoid name	Major axis (a)	Reverse flattening (rf) / Minor axis (b)	Description
GRS67	a=6378160.0	rf=298.2471674270	GRS 67(IUGG 1967)
bessel	a=6377397.155	rf=299.1528128	Bessel 1841
bess_nam	a=6377483.865	rf=299.1528128	Bessel 1841 (Namibia)
clrk66	a=6378206.4	b=6356583.8	Clarke 1866
clrk80	a=6378249.145	rf=293.4663	Clarke 1880 mod.
CPM	a=6375738.7	rf=334.29	Comm. des Poids et Mesures 1799
delmbr	a=6376428	rf=311.5	Delambre 1810 (Belgium)
engelis	a=6378136.05	rf=298.2566	Engelis 1985
evrst30	a=6377276.345	rf=300.8017	Everest 1830
evrst48	a=6377304.063	rf=300.8017	Everest 1948
evrst56	a=6377301.243	rf=300.8017	Everest 1956
evrst69	a=6377295.664	rf=300.8017	Everest 1969
evrstSS	a=6377298.556	rf=300.8017	Everest (Sabah & Sarawak)
fschr60	a=6378166	rf=298.3	Fischer (Mercury Datum) 1960
fschr60m	a=6378155	rf=298.3	Modified Fischer 1960
fschr68	a=6378150	rf=298.3	Fischer 1968o
helmert	a=6378200	rf=298.3	Helmert 1906
hough	a=6378270.0	rf=297	Hough
intlh	a=6378388.0	rf=297	International 1909 (Hayford)
krass	a=6378245.0	rf=298.3	Krassovsky, 1942
kaula	a=6378163	rf=298.24	Kaula 1961
lerch	a=6378139	rf=298.257	Lerch 1979
mprts	a=6397300	rf=191	Maupertius 1738
new_intl	a=6378157.5	b=6356772.2	New International 1967
plessis	a=6376523	b=6355863	Plessis 1817 (France)
SEasia	a=6378155.0	b=6356773.3205n	Southeast Asiae
walbeck	a=6376896.0	b=6355834.8467	Walbeck
WGS60	a=6378165.0	rf=298.3	WGS60
WGS66	a=6378145.0	rf=298.25	WGS66
WGS72	a=6378135.0	rf=298.26	WGS72
WGS84	a=6378137.0	rf=298.257223563	WGS84

Available projections in SIS

- UTM – Universal Transverse Mercator.

When selecting UTM you will be prompted for UTM zone and whether you are on northern or southern hemisphere

- UPS – covers the polar regions

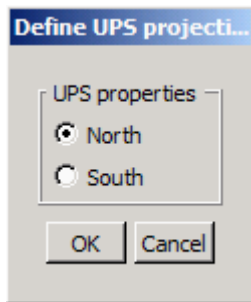

- Mercator

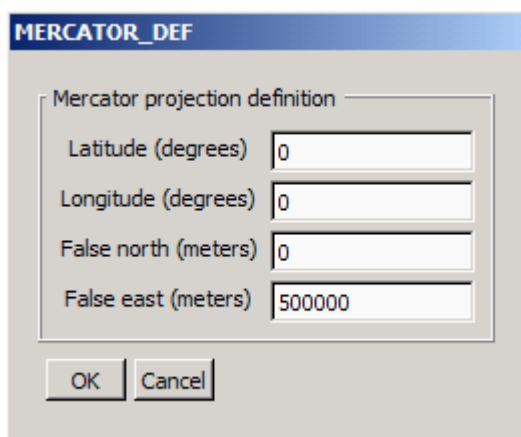

You will be prompted for latitude and longitude of origin, false northing and false easting.

- Transverse Mercator (TM)

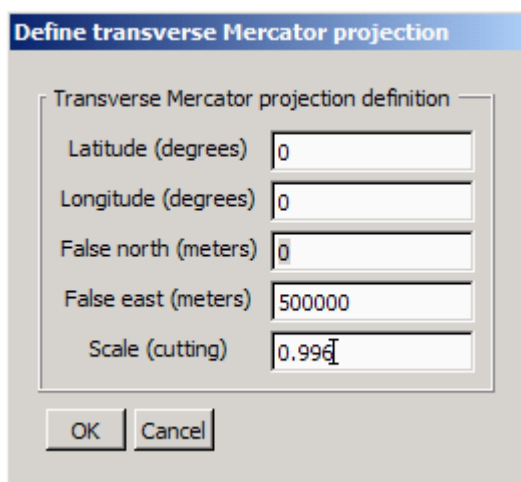

Same parameters applies to the Transverse Mercator as for the Mercator. In addition a scale factor for the central meridian must be input

- User defined – selected by number from in the static and dynamic libraries. These projections are identified by a unique number known to the user. You can choose this number in the User’s projection dialogue. If this number is not implemented, the selection procedure will exit.

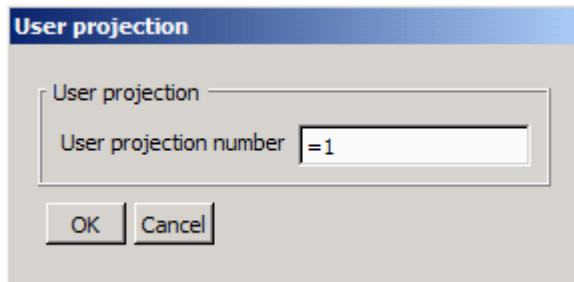

By selecting =1 the Gauss Krüger projection will be selected. See *Gauß Krüger* on page 390

- PROJ.4 definition – enables input of programmable datum transformation and/or projection parameters

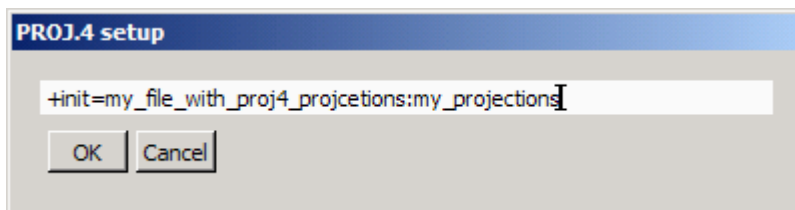

The PROJ.4 style must be entered in the following format:

```
+init=my_file_with_proj4_projections:my_projection
```

Note

The following will fail:

```
+init=c:\mydir\myfile.txt:my_projection
```

because the first : is not allowed. This means that your projection file have to be on the same disk

Support user defined projections

Gauß Krüger

Enter **User's projection number = 1** in the dialogue window. The parameters for the projection can be controlled in a file named **projection.data** like this:

GK_AUSTRIA	GK_AUSTRIA tells Software to use Gauß-Kruger for Austria
	Transformation parameters for WGS84 to Gauss-Krüger coordinates according to Datum MGI
-603.919	Translation in x [m]
-71.656	Translation in y [m]
-433.142	Translation in z [m]
-4.377582	Scale
0.757332	Rotation in x ["]
0.334161	Rotation in y ["]
-1.604013	Rotation in z ["]
6377397.155	Major axis [m] (Bessel)
299.152815	Flattening (Bessel)
12.0	Central Meridian (Bessel)
6378137.0	Major axis (WGS84)
298.257223563	Flattening (WGS84)
4500000	Zuschlag Rechtswert
0	Zuschlag Hochwert
0	Fixed height used in projections

Hungary

User projection number = 2. This is a projection for the Budapest area.

Related operational procedures

- *How to define a new projection and datum transformation* on page 122

Related topics

- *Projection parameters* on page 269
- *Projections* on page 513

Help menu dialogs

The **Help** drop-down menu gives you the following choices:

- *Help* on page 391
- *Build info* on page 391

- *OpenGL settings* on page 392
- *About SIS...* on page 392

Help

Help is accessed from the **Help** menu.

It will open the online-help manual applicable to your system.

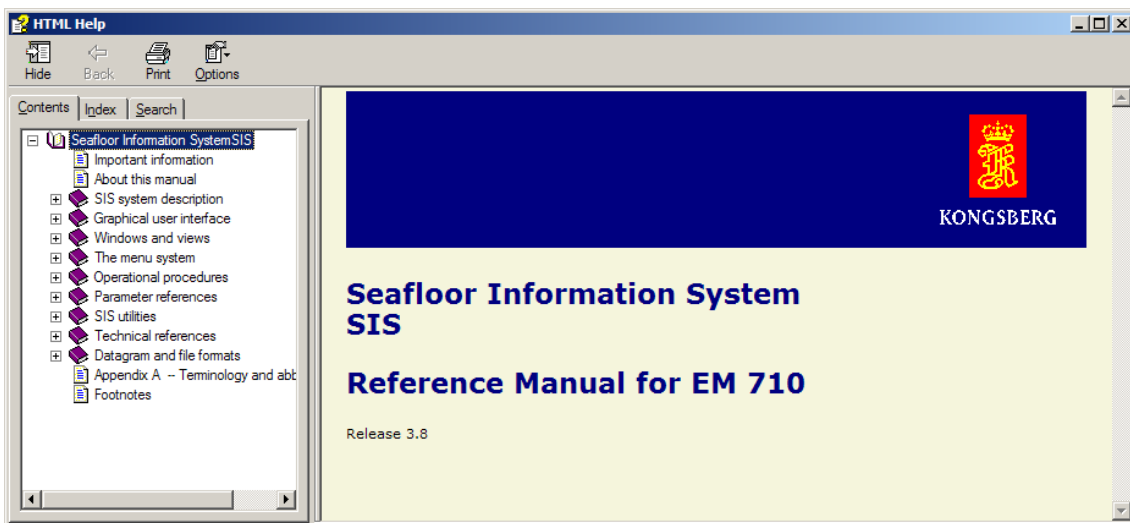

Build info

The **Build Info** message box is accessed from the **Help** menu.

It contains information about the current SIS software build.

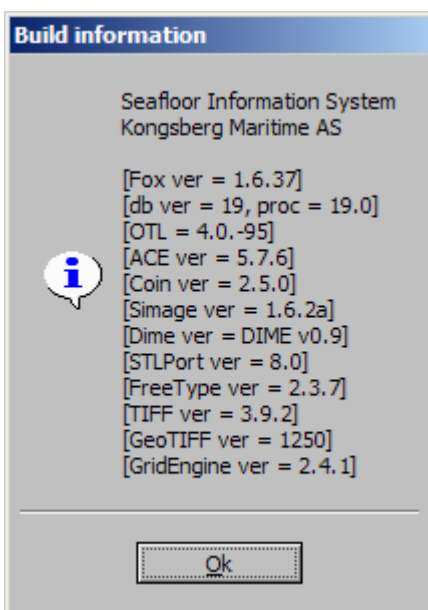

OpenGL settings

The **OpenGL Settings** message box is accessed from the **Help** menu.

It provides the following information about the **OpenGL settings**:

- Driver information
- Display mode
- Available extensions

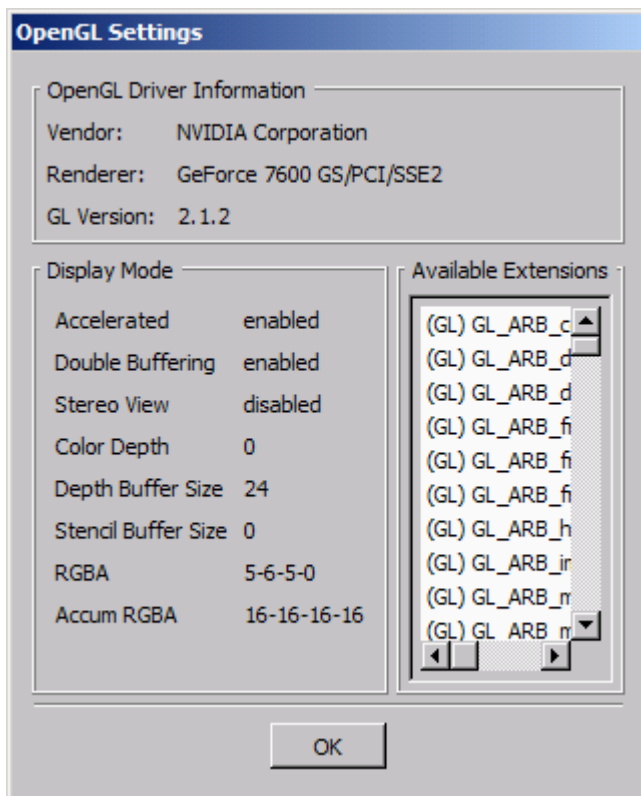

About SIS...

The **About SIS** message box is accessed from the **Help** menu.

It contains general information about the SIS software and the release version of the supported echo sounder.

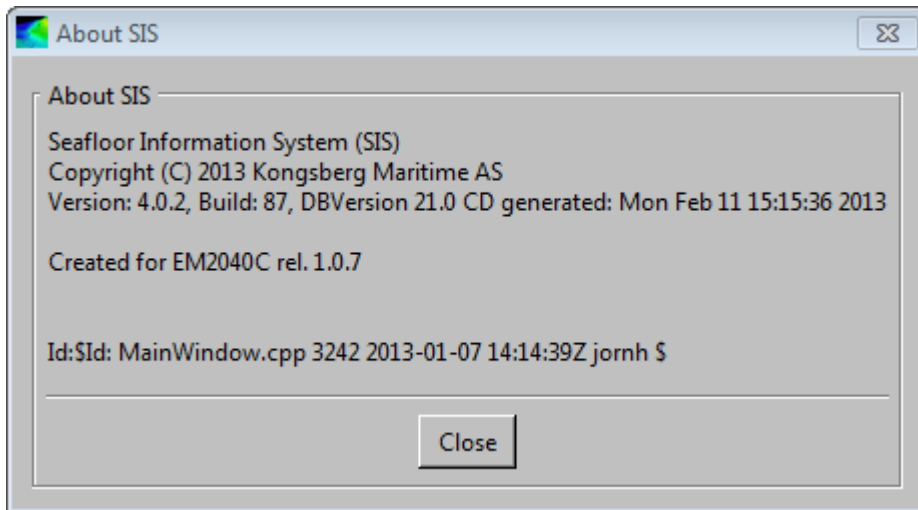

This message box can also be accessed by pressing the SIS icon on the status bar in lower right corner .

SIS utilities

This chapter provides description of operation and parameter setup of utility programs related to SIS. Some are accessed directly from SIS.

Topics

- *SVP Editor* on page 395
- *Raypaths chart* on page 401
- *SeaCast* on page 405
- *SVP Logger* on page 406
- *SeaCal* on page 409
- *SIS Objects* on page 417
- *Logging utilities* on page 435
- *C-MAP CM-93/3* on page 443
- *Global event marker* on page 447
- *PU simulator and playback* on page 449
- *Create grid from ASCII files* on page 451
- *KSGPL* on page 453
- *Input of S-57 formatted chart files* on page 458
- *How to use SIS on an AUV/ROV* on page 460
- *CUBE* on page 464
- *Precise Point Positioning (PPP) in SIS* on page 476
- *GSF support in SIS* on page 483

SVP Editor

The **SVP Editor** is used to load and edit the sound speed profiles logged in **.asvp** or **.actd** formatted files. This is a utility program to SIS and holds a number of tools to assist in creating a good sound velocity profile, including manual editing.

The main user interface for the SVP Editor is shown in figure below.

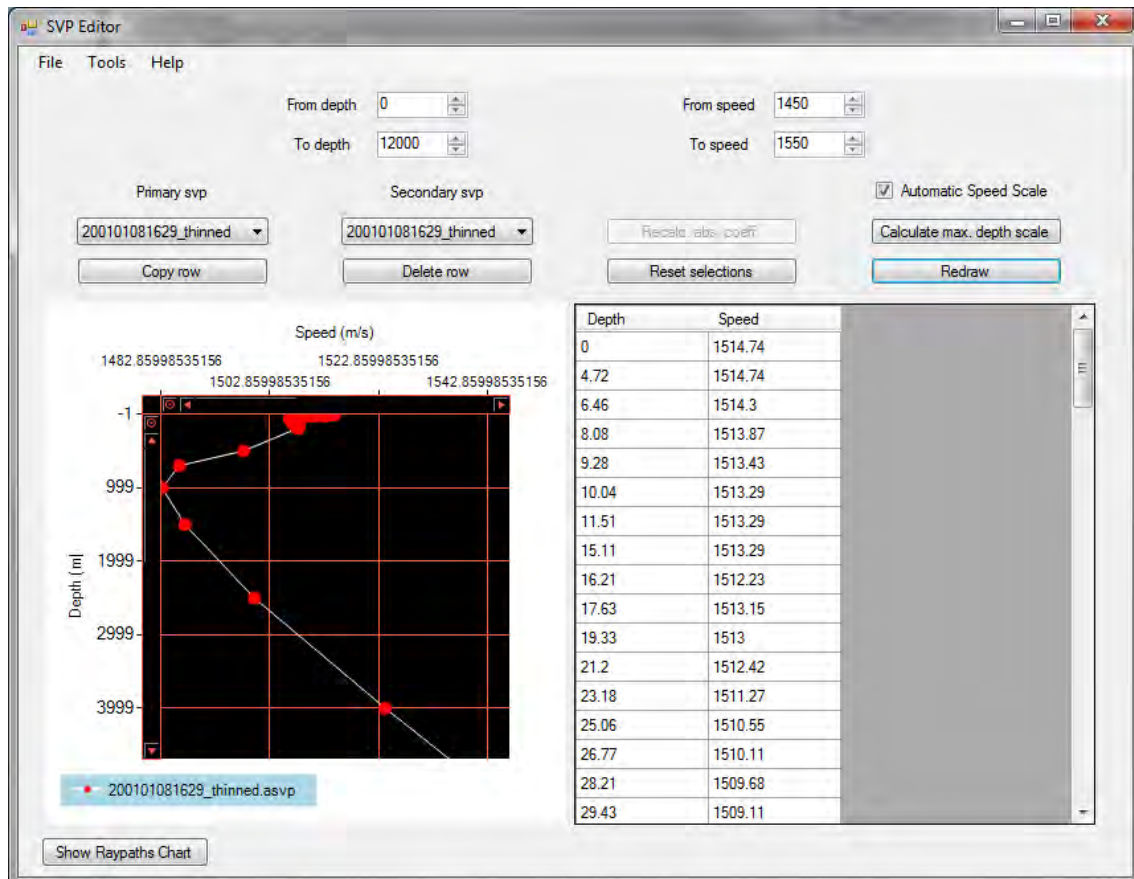





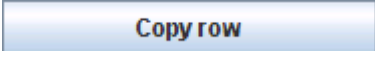

Main menu

The main menu of the **SVP Editor** holds the following selections:

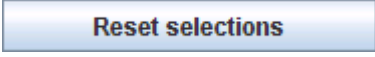
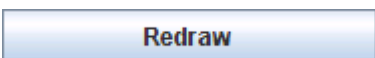
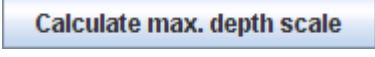
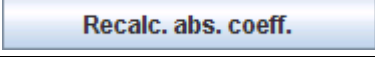
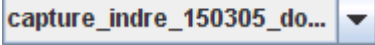
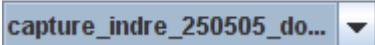
- File menu, see *File menu* on page 397
- Tools menu, see *Tools menu* on page 398
- Help menu

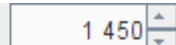
Buttons

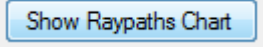
Select	To
	Copy selected row in the table. This allows you to add values to the profile because a copied row can be edited.
	Delete all selected rows in the table
	Reset all selections that you have done
	Redraw the profiles. You have to use this button after selecting rows in order to identify the selected value.
	Redraw the profile using the depth scale that fills the display window. The profiles are by default drawn using 100 metres maximum depth.
	Recalculate an absorption coefficient in a cell from previous and next values in that column.
<div style="background-color: #f0f0f0; padding: 2px;">Primary svp</div> 	Select your primary sound velocity profile. All loaded profiles can be selected from the pull-down menu. The primary SVP is drawn using red circles and white lines.
<div style="background-color: #f0f0f0; padding: 2px;">Secondary svp</div> 	Select a secondary sound velocity profile. Showing a second sound velocity profile is useful for quality controlling the primary SVP. The secondary using blue circles and green lines.
From depth <input type="text" value="0"/>  To depth <input type="text" value="26"/> 	Set the start and maximum depth to be displayed. When set the display window can be scrolled up and down remaining the same relative scale. The difference between minimum and maximum depth have to be 5 meters or more.
From speed <input type="text" value="1 450"/>  To speed <input type="text" value="1 550"/> 	Set the minimum and maximum speed to be displayed. The setting of these parameters can be useful to scroll the display in the speed direction.
<input checked="" type="checkbox"/> Automatic speed scale	Automatically compute the best fit for minimum and maximum speed. The From speed and To speed settings are overridden.
	Show the Raypaths chart , a tool for visualizing the effect a given sound velocity profile has on propagation of the echo sounder beams.

The graphical display

The loaded profiles will be displayed in a graphical display having depth and sound velocity speed as vertical and horizontal axes.

The Numerical display

The numerical table to the right shows the data from the primary svp. You can at any time change the values in this table. Press **Return** to see the effects in the profile.

When selecting a value in the profile, the row in the table will be selected as well. Note that the table may be too big to fit in the window. You may have to scroll the table to see the selected row.

Raypaths chart

Raypaths chart is a tool for visualizing the effect a given sound velocity profile has on propagation of the echo sounder beams. **SVP effects** will display nine sample beams throughout the swath. The **Raypaths chart** also gives the opportunity to compare the effect the use of two different sound velocity profiles will have on the beam propagation.

Raypaths chart on page 401

Note _____

The former SVP effects tool is now replaced by this functionality inside the SVP Editor.

File menu

- **Open:** Open a **.asvp** or **.actd** file and make the profile primary
- **Open in editor:** Open selected file in a separate raw editor program
- **Save as:** Save the primary svp with a name of your choice
- **Save primary svp:** Save the primary svp to its original file.

Note _____

The original file will be overwritten.

- **Send primary svp to echosounder:** Information about the primary svp is sent to SIS where all mean absorption coefficients are recalculated using the depths found in the **.asvp** file

If the selected profile have no associated absorption coefficients files a warning message will be issued, and no absorption coefficients file updates will be performed.

Note _____

The svp must be selected in the Sound Speed frame in the Runtime parameters view, for active use.

- **Close primary svp:** Close primary svp and remove it from the editor. Note that it will not be saved.
- **Close all:** Close all profiles and remove them from the editor. Note that the profiles are not saved.
- **Exit:** Exit the program. Note that unsaved profiles are not saved.

Tools menu

- **Check profile:** Check that the primary sound speed profile not contains upwards bends in the depth
- **Check profile automatic:** Automatic check for depth bends.
- **Extend profile...:** The current profile can be extended with values read from a file.

Note

The profiles must be of the same type, i.e. they must all be without absorption coefficient files. A warning is given if svp's of different types are used.

Note

Extending actd files may require manual work to verify the extended values are correct.

- **Extend profile:** The profile will be extended down to 12,000 meters. Note that the profile must be continuous for this operation to be carried out. If not all depths in the profile are ascending, the rows where the depth is equal or above the previous row will be selected. You can then press **Delete rows** and delete them. Now this operation can be carried out. Extending an **.actd** file may require manual work to verify that the extended values are correct.
- **Extend2:** The sound speed profile will be extended according to Leroy et. al. 2008: "A new equation for the accurate calculation of sound speed in all oceans". The equation in Leroy et. al. calculates the sound speed profile from input of latitude, temperature, salinity and pressure.
- **Replace primary with data from secondary:** If the primary svp contains depths from 0 to 12,000 meters and the secondary contains data from 0 to 100 meters, the values from 0 to 100 meters in the primary svp will be replaced with the data from the secondary svp.
- **Thin profile:** Thin the profile by removing some points. You have to enter a thinning factor (0.01 to 3.0). The smaller the factor, the less thinning will be done. The results from the thinning is then presented in a table, see the figure below. Note that this operation requires that the profile is extended.

Thinning results table

The thinned primary svp is written to a file with **thinned** appended to the filename of the primary svp. The **thinned** profile is then automatically read into SVP Editor.

The **Thinning results table** shows the results from using the original and the thinned profile. Each table has selected beam pointing angles as columns and selected depths as rows. The approximate depth used is listed in the column to the left.

Note that the depth used in the calculations will differ from this depth because the raypath routine requires time as input, and the time is computed from the depth and the average sound speed in the profile, which will be different from the true profile.

Results of thinning

Warning threshold (m) First table is depth differences (m) Second table is horizontal differences (m)

Depths: Beam angle	0	10	20	30	40	50	60
5.00	4.79/4.79	4.79/4.79	4.79/4.79	4.79/4.79	4.79/4.79	4.79/4.79	4.79/4.79
10.00	9.59/9.59	9.59/9.59	9.59/9.59	9.59/9.59	9.59/9.59	9.59/9.59	9.58/9.58
20.00	19.17/19.17	19.17/19.17	19.17/19.17	19.17/19.17	19.17/19.17	19.17/19.17	19.17/19.17
50.00	47.93/47.93	47.93/47.93	47.93/47.93	47.93/47.93	47.93/47.93	47.92/47.92	47.91/47.91
100.00	95.88/95.88	95.88/95.88	95.88/95.88	95.87/95.87	95.86/95.86	95.84/95.84	95.79/95.79
200.00	192.04/192.04	192.03/192.03	191.99/191.99	191.93/191.93	191.80/191.80	191.56/191.56	191.03/191.03
500.00	483.64/483.64	483.50/483.50	483.04/483.04	482.14/482.14	480.47/480.47	477.24/477.24	470.13/470.13
1000.00	970.82/970.82	970.43/970.43	969.15/969.15	966.62/966.62	961.90/961.90	952.68/952.68	931.76/931.76
2000.00	1944.59/1944.59	1943.71/1943.71	1940.84/1940.84	1935.14/1935.14	1924.59/1924.59	1904.11/1904.11	1858.39/1858.39
4000.00	3918.12/3918.12	3915.37/3915.37	3906.39/3906.39	3888.63/3888.63	3855.87/3855.87	3792.72/3792.72	3654.08/3654.08
6000.00	5934.46/5934.46	5928.28/5928.28	5908.13/5908.13	5868.26/5868.26	5794.85/5794.85	5653.77/5653.77	5346.04/5346.04

Depths: Beam angle	0	10	20	30	40	50	60
5.00	0.00/0.00	0.85/0.85	1.74/1.74	2.77/2.77	4.02/4.02	5.71/5.71	8.30/8.30
10.00	0.00/0.00	1.69/1.69	3.49/3.49	5.53/5.53	8.04/8.04	11.42/11.42	16.60/16.60
20.00	0.00/0.00	3.38/3.38	6.98/6.98	11.07/11.07	16.09/16.09	22.85/22.85	33.21/33.21
50.00	0.00/0.00	8.45/8.45	17.45/17.45	27.68/27.68	40.23/40.23	57.13/57.13	83.04/83.04
100.00	0.00/0.00	16.91/16.91	34.91/34.91	55.38/55.38	80.48/80.48	114.31/114.31	166.13/166.13
200.00	0.00/0.00	33.92/33.92	70.02/70.02	111.07/111.07	161.42/161.42	229.26/229.26	333.20/333.20
500.00	0.00/0.00	86.06/86.06	177.64/177.64	281.78/281.78	409.51/409.51	581.56/581.56	845.03/845.03
1000.00	0.00/0.00	173.38/173.38	357.90/357.90	567.73/567.73	825.14/825.14	1172.00/1172.00	1703.57/1703.57
2000.00	0.00/0.00	347.82/347.82	717.95/717.95	1138.83/1138.83	1655.08/1655.08	2350.50/2350.50	3415.63/3415.63
4000.00	0.00/0.00	706.06/706.06	1457.34/1457.34	2311.42/2311.42	3358.56/3358.56	4767.98/4767.98	6922.90/6922.90
6000.00	0.00/0.00	1079.99/1079.99	2228.96/2228.96	3534.65/3534.65	5134.34/5134.34	7284.56/7284.56	10562.95/10562.95

In the first table the depths from the two profiles are shown, and in the second table the horizontal placement is shown using both profiles.

In the text field on top you can set the difference between the two profiles to be shown. If the difference between the original and the thinned profile is larger than the values set (remember to press Return for the value to take effect), the background of the cell will be set to red.

You can save these results to file by pressing the **Print...** button.

Press **OK** to return to the SVP Editor.

Note

When receiving SSP datagrams from external sound velocity sensors the following should be noted:

- *S0x format types intended for immediate use and containing no errors will never start the SVP Editor. If an error is detected the SVP Editor will be started only when enabled.*
 - *All other format types will start the SVP editor when received if the startup is enabled.*
-

Related operational procedures

- *How to collect the sound velocity profile on page 141*
- *How to use SmartTalk on page 142*
- *How to use csv2asvp on page 143*
- *How to use SVP Logger on page 144*
- *How to use SVP Manager on page 145*
- *How to use SVP Editor to convert an SVP file to .asvp format on page 147*
- *How to modify and load a sound speed profile into SIS on page 151*

Related topics

- *Raypaths chart on page 401*
- *SVP Logger on page 406*

Raypaths chart

Note

*This functionality inside the **SVP Editor** is replacing the **SVP effects** tool in the previous versions of SIS.*

Raypaths chart is a tool for visualizing the effect a given sound velocity profile has on propagation of the echo sounder beams. **SVP effects** will display nine sample beams throughout the swath. **Raypaths chart** also gives the opportunity to compare the effect the use of two different sound velocity profiles will have on the beam propagation.

Topics

- *User interface* on page 401
- *What you see* on page 404

Related operational procedures

- *How to collect the sound velocity profile* on page 141
- *How to use SmartTalk* on page 142
- *How to use csv2asvp* on page 143
- *How to use SVP Logger* on page 144
- *How to use SVP Manager* on page 145
- *How to use SVP Editor to convert an SVP file to .asvp format* on page 147
- *How to modify and load a sound speed profile into SIS* on page 151

Related topics

- *SVP Editor* on page 395
- *SVP Logger* on page 406

User interface

How to open Raypaths chart

Raypaths chart is a functionality in the **SVP Editor**:

- 1 In the **SVP Editor** click on the **Show Raypaths Chart** button. An area for the ray paths will be shown in the in the **SVP Editor** together with the buttons **Hide Raypaths Chart** and **Update Raypaths Chart**.
- 2 Click on the **Update Raypaths Chart** button and the beams for the selected primary and secondary `.asvp` files will appear.

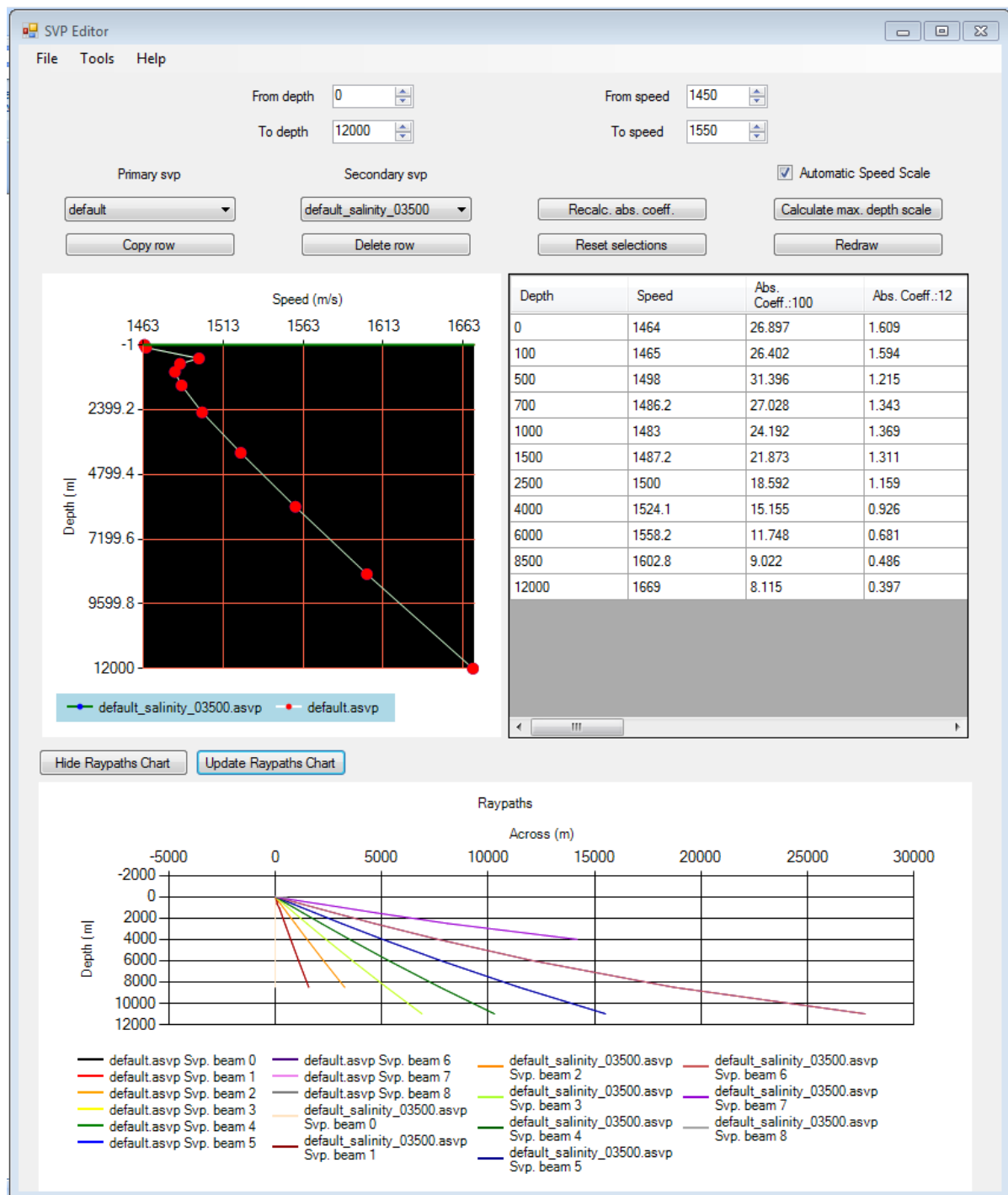

How to use Raypaths chart

The **File** menu contains the following options:

- 1 Select **File**→**Open**.

This will bring up a file selection dialog where you select an asvp formatted sound velocity profile file to use as primary or secondary sound speed profile.

- 2 Select your **Primary SVP** .asvp filename and press the **Open** button.

The following window will be displayed.

3 Select **File** → **Open**.

This will again bring up the file selection dialog.

4 Select an **asvp** formatted sound velocity profile file again.

5 Click on the **Primary SVP** pull-down menu and select your primary sound velocity profile.

6 Click on the **Secondary SVP** pull-down menu and select your secondary sound velocity profile.

7 Click on the **Update Raypaths Chart** button and the beams for the selected primary and secondary **.asvp** files will appear.

Zooming in and out

Zoom in by pressing the left mouse button on the top-left corner, hold down the mouse button while dragging it to the lower-right corner and release the mouse button.

Zoom out by pressing the left mouse button in the lower-right corner, hold down the mouse button while dragging it to the upper-left corner and release the mouse button.

Note

Zooming operations applies both to the Sound speed plot and the Across coverage plot.

Quick menu

By pressing **right mouse** button in the **Raypaths chart** area in the **SVP Editor** dialog box a **Quick menu** will appear. This menu contains the following options:

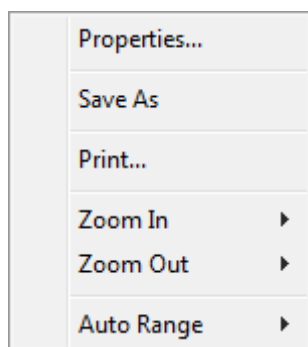

- **Properties:** Allows you to set up the chart properties, such as labels, fonts, colours etc.
- **Save as:** Brings up a dialog that allows you to save the plots as a PNG graphic file.
- **Print:** Opens a **Page setup** dialog where you can set your print preferences and print the view.
- **Zoom in/out:** You can select to zoom in/out either the domain axis, the range axis or both. Zooming will apply to where your mouse was positioned when the **Quick menu** was opened.
- **Auto range:** Can be selected for either the domain axis, the range axis or both.

Note

Zooming operations applies both to the Sound speed plot and the Across coverage plot.

What you see

For each sound velocity profile, either the reference or the compare SVP, the across propagation for nine beams are displayed.

The nine beams are 0 degrees (straight down), then 10, 20, 30, 40, 50, 60, 70 and 80 degrees to the side. The depths and the across values are calculated for each beam for each travelling time.

SeaCast

SeaCast is a Windows based program that provides a user interface to AML's latest generation of water instrumentation.

SeaCast is not a Kongsberg Maritime software.

For further information please visit <http://www.amloceanographic.com>.

Note

*The **SmartTalk** application from AML has been replaced with **SeaCast**. It is used to interface with probes from AML and can be installed together with SIS or by launching the installer from the Seacast folder on the SIS CD.*

Related topics

- *SVP Editor* on page 395
- *Raypaths chart* on page 401
- *SVP Logger* on page 406

What it does

SeaCast is used to configure AML instruments, monitor data in real-time, and review logged data.

How to install

The program can be installed using the SIS CD.

How it works

Normally the **SeaCast** program is located under C:\Program Files\SeaCast. If the .exe file is not routed to the desktop, the **SeaCast** program can be started from this location.

The SeaCast user interface is divided into 3 pages or tabs:

- **Instrument page:** The Instrument page is the starting page for **SeaCast**. This page allows the user to connect to and identify an instrument and its sensors.
- **Setup page:** The Setup page allows the user to view and modify the sampling and logging settings of the instrument.
- **View Data:** The View Data page allows the user to view data in graphical or table format.

SVP Logger

SVP Logger logs raw data from **Morse** and **AML SVP** sensors and converts the data to **.asvp** format

Related operational procedures

- *How to collect the sound velocity profile* on page 141
- *How to use csv2asvp* on page 143
- *How to use SVP Logger* on page 144
- *How to use SVP Manager* on page 145
- *How to use SVP Editor to convert an SVP file to .asvp format* on page 147
- *How to modify and load a sound speed profile into SIS* on page 151

Related topics

- *SVP Editor* on page 395
- *Raypaths chart* on page 401

Running the program

This program is an interface program for handling the Morse and AML SVP sensor.

For setting up the communication parameters for the probe, please refer to *External sensors* on page 371

Using the program

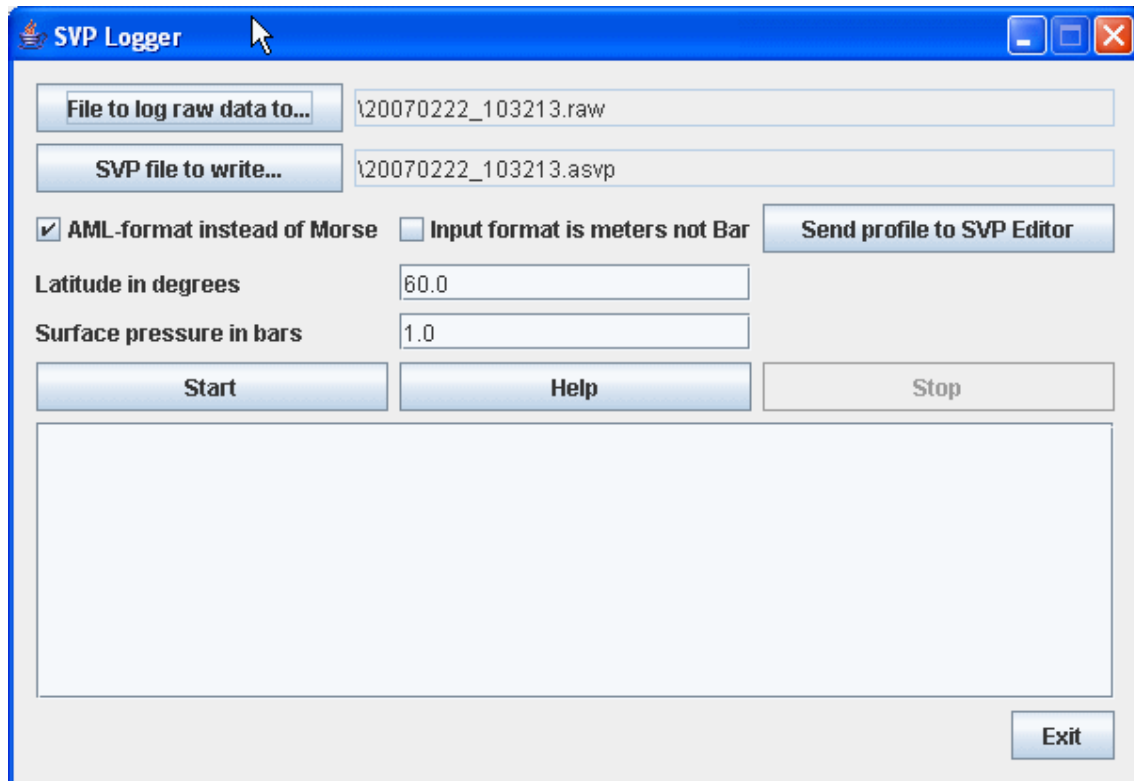

The main user interface holds the following:

File to log raw data to...: Select the raw data destination file for the data from the SVP sensor.

SVP file to write...: Set the filename the SVP will be written to. This file should end with .asvp.

AML-format instead of Morse: If the button AML-format is enabled and not Morse, AML and Valeport formats are accepted instead. Then this program can be used to create sound speed profiles from these sensors as well.

Input format is meters not Bar: If the input format is meters, enable the checkbox **Input format is meters, not dBar**. This will disable the conversion from dBar to meters. You have to know in which format your sensor has been set up.

Send profile to SVP Editor: When you press **Send profile to SVP Editor**, SVP Editor will load the .asvp file if the SVP Editor is up and running. Note that pressing this button twice will NOT reload the file in the SVP Editor. If you want to send it again, you have to close the file in the SVP Editor first and then press this button again.

Latitude in degrees: Enter the latitude in degrees. It is used to calculate the correct depth.

Surface pressure in bars: Enter the surface pressure in bars. It is used to calculate the correct depth.

When you press **Start**, the values from the COM port will be displayed in the SVP window. When you press **Stop**, the contents of the .asvp file is shown.

Note

The .asvp file should be edited afterwards. The time and the location in the header is not correct and must be corrected.

You must also make sure that the profile contains a values at exactly 0.0 and at 12,000 meters depth.

If the file contains a great number of values, you should consider thinning the values.

SeaCal

SeaCal is a program used to compute the calibration values of the multibeam echo sounder.

Related operational procedures

- *How to determine calibration values using SeaCal automatic calibration* on page 184

Related topics

- *AutoCalib Wizard* on page 380
- *SeaCal results* on page 381
- *Seacal auto calibration* on page 261

What it does

Reliable data from the multibeam echo sounder can only be acquired after proper calibration of the static offsets in system parameters such as roll, pitch, heading, eccentricity of the transducer relative the antenna of the positioning system etc.

This calibration method is based on global match of the calibration lines. It does not presume that we have information about the true relief of the seafloor. The method computes the calibration parameters from least squares adjustment, and it offers a broad range of static offset parameters to be computed and the derivation of the correlation between them. The program computes calibration parameters from parallel or crossing lines. The calibration lines must follow straight lines, i.e., curved calibration lines are not allowed. The number and the length of the lines are limited by the amount of computer memory and the speed of the computer processor. The figure below shows the coordinate axes used.

Figure 24 Definition of the coordinate axes

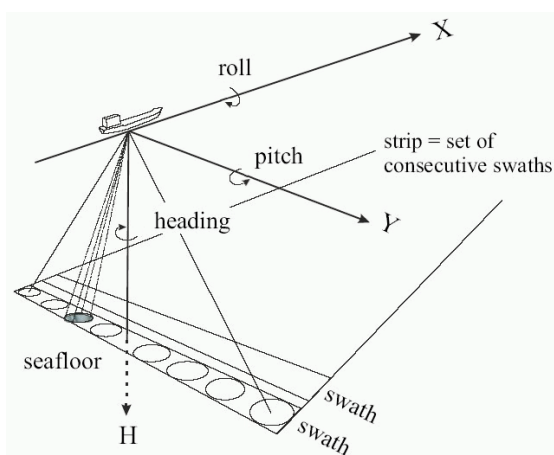

Calibration parameters

SeaCal is able to compute several kinds of calibration parameters. The two main groups of parameters are those common and individual for the lines. The following calibration parameters are defined:

	Symbol	Definition
Roll	$\Delta\Phi$	$\Phi' = \Delta\Phi + \Phi$
Pitch	$\Delta\omega$	$\omega' = \Delta\omega + \omega$
Heading	$\Delta\kappa$	$\kappa' = \Delta\kappa + \kappa$
Translation in x	Δx	$x_0' = \Delta x + x_0$
Translation in y	Δy	$y_0' = \Delta y + y_0$
Relative tide correction	Δh_0	$h_0' = \Delta h + h_0$
Roll scale factor	m_Φ	$\Phi' = m_\Phi \Phi$
Horizontal scale factor	m_y	$y' = m_y y$

x is measured along the line and y is perpendicular to x, so y is measured in the swath direction.

Factor m_Φ is a kind of parameter related to the inner calibration of the multibeam echo sounder, but it can also be explained by uncertain computation of the refraction of the beams, i.e., the accuracy of the sound speed profile. Parameter m_y is a horizontal scale factor in the swath direction. It is motivated from the influence of errors in the sound speed.

Design of the calibration lines

The accuracy of the calibration depends on the topography of the seafloor, and the configuration of the calibration lines. Therefore, the calibration lines should be located in an area with satisfactory relief and they should follow a certain pattern, i.e., a configuration that allows the computation of the parameters.

The **Effect of offset** figure below illustrates the effect of offsets in the calibration parameters. From the figure we observe that calibration for heading and the two scale factors require lines with parallel displacement. Offsets in roll, pitch, x and y are best computed from lines in opposite directions which overlap each other 100%.

Figure 25 *Effect of offsets in the calibration parameters*

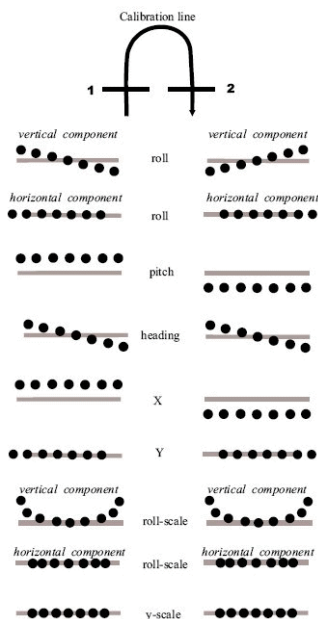

Roll and roll scale have a vertical and a horizontal component. Their vertical component makes it possible to calibrate them even in a flat area.

The horizontal component of $\Delta\Phi$ has very similar influence on the measured depth values as Δy . This correlation is not a problem in field calibration, since the vertical component of $\Delta\Phi$ separates it from Δy .

Offsets in pitch and x have also very similar error patterns. Therefore, the two parameters are often highly correlated. Their separation depends on the relief of the seafloor. They can be separated if the seafloor has satisfactory depth variation.

Pitch, heading and x calibration require that the lines run in the direction of the terrain slope, whereas y and Y-scale calibration require terrain slope across the run direction.

Based on the geometric interpretation of the **Effect of offset** figure above, we can conclude that we need at least three calibration lines in order to compute all the parameters, i.e., two 100% overlapping lines for the computation of $\Delta\Phi$, $\Delta\omega$, Δx and Δy , and a third line for $\Delta\kappa$, m_Φ and m_y .

Since the random measurement errors of the multibeam echo sounder and the relief of the seafloor have great impact on the accuracy of the parameters, calibration lines in addition to the minimum required will strengthen the calibration. For example, we can apply four, eight or twelve lines as illustrated in the **Configurations** figure below. How many lines to measure, depends on the relief of the seafloor, the period of time available for the calibration etc., but as a rule eight crossing lines is recommended. Eight crossing lines balance the requirement of accuracy and the cost of running the calibration lines.

How to run SeaCal

There are several ways to run SeaCal, but to get a safe and fast verification of the calibration parameters, the following procedure is recommended.

- 1 Apply eight crossing calibration lines as defined in the Configurations figure below.
- 2 Run the calibration with all parameters
- 3 Run the reliability computation
- 4 Introduce the calibration values with green reliability factor into the multibeam system
- 5 Run a new calibration to verify the new settings

Figure 26 Different configurations of calibration lines

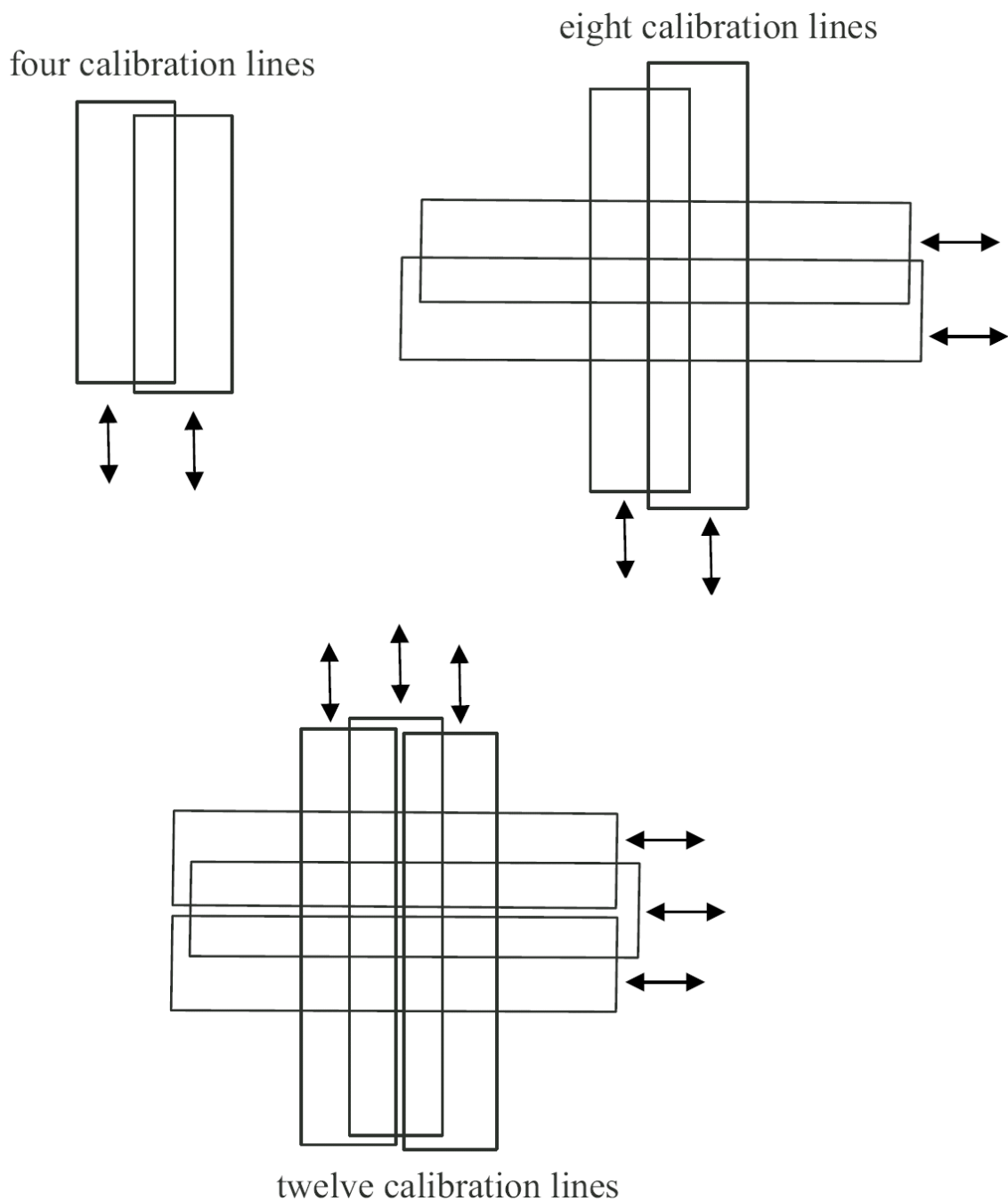

Resolution

The resolution of the grid model applied in the calculation effects the computing time. The option auto asks SeaCal to compute the resolution, but you can also define the resolution manually.

Maximum number of iterations

Usually, SeaCal needs two or more iterations to compute the calibration. You can define the maximum number of iterations manually, or you select auto, i.e., SeaCal iterates until the solution is stable.

More on the field calibration method

A strength of our approach is that all the survey lines are utilized in an optimal way, i.e., survey lines which cannot determine a parameter, will have minor influence on the computation. For a thorough description of the method see [2].

Often the eccentricity of the transducer is measured by land surveying methods. Since our calibration method considers the horizontal offsets in x and y, it can control that the horizontal eccentricity values are loaded correctly into the multibeam system.

SeaCal computes calibration parameters based on least-squares adjustment as:

$$V = \left(A^T P_1 A \right)^{-1} A^T P_1 L_1 \quad (1.1)$$

where V is a vector of the unknown parameters, A a coefficient matrix, P₁ a weight matrix and L₁ a vector of observations.

Since the stability of the system of equations depends on the relief of the seafloor and the configuration of the calibration lines, restrictions are put on the unknown parameters by:

$$V = \left(A^T P_1 A + P_2 \right)^{-1} \left(A^T P_1 L_1 + P_2 L_2 \right) \quad (1.2)$$

where P₂ is a weight matrix of the unknown parameters and L₂ a vector of a priori parameter value.

The variance-covariance matrix of the unknowns are computed from:

$$Q_V = \left(A^T P_1 A + P_2 \right)^{-1} \quad (1.3)$$

Here, the diagonal elements define the variance of the parameters and the other elements their covariance. Therefore, the variance $\sigma_{v_i}^2$ of parameter V_i is derived as:

$$\sigma_{v_i}^2 = Q_{v_{ii}}$$

and the covariance $\sigma_{v_i v_j}$ of the two parameters V_i and V_j is computed as:

$$\sigma_{v_i v_j} = Q_{v_{ij}}$$

The correlation coefficient $\sigma_{v_i v_j}$ measures how separable two parameters V_i and V_j are and is derived from Q_V as:

$$\rho_{v_i v_j} = \frac{\sigma_{v_i v_j}}{\sigma_{v_i} \sigma_{v_j}} \quad (1.4)$$

In multibeam echo sounder calibration we usually have limited knowledge of the stochastic properties of the observations. Therefore, the standard deviation of the parameters we compute from (1.3), will be too optimistic. For this reason, we define a reliability factor R which measures the ability of the geometry to determine the calibration parameters.

The computation of R is done in a simulation procedure. In the first round the calibration V' is computed. Thereafter, the measurements are corrected according to vector ϵ of offset values and a new calibration V'' is computed with ϵ as the start value of the computation. Ideally, V' and V'' should be equal, but due to many error sources, the two may be different. The reliability factor for parameter v is computed as:

$$R = \begin{cases} 1 - \left| \frac{v' - v''}{\epsilon_v} \right| & \text{for } |v' - v''| < |\epsilon v| \\ 0 & \text{Otherwise} \end{cases} \quad (1.5)$$

From the definition we recognize that R is defined on the interval $[0,1]$. Factor 1.0 means that the simulated offset is completely determined, but from the factor value considered, we cannot draw the conclusion that the parameter is computed with no uncertainty. The maximal factor value only tells us that we have a strong geometry. In general, we can say that for low values of the reliability factor we should supplement the configuration with additional calibration lines.

The interpretation of R must also consider the weight of the parameters. If $R \approx 1$, it may happen that the parameter is given high weight. This is the case if the parameter is to be fixed to its initial value.

The reliability test is very important since it gives a comprehensive control of the calibration. Generally, it is hard to prove that a computer program works as it should, but the reliability test covers both the implementation of the calibration procedure as well as the configuration of the calibration lines.

The calibration lines must follow straight lines, i.e., curved calibration lines are not allowed. The number and the length of the lines are limited by the amount of computer memory and the speed of the computer processor.

Bibliography

[1]

Jan Terje Bjørke. En metode for feltkalibrering av systemparametere i et multistråleekkolodd-system (Eng. A method for field calibration of system parameters in a multibeam echo sounder system. Norwegian patent no. 315766, Norwegian Patent Office, PO Box 8160 Dep. 0033, Oslo, Norway, 2004.

[2]

Jan Terje Bjørke. Optimal method for field calibration of multibeam echo sounders.
Submitted IEEE Journal of Oceanic Engineering, 2004

SIS Objects

This section describes how to operate **SIS Objects**. **SIS Objects** is a tool for adding points, lines, images, text, polygons, video and html into the map in SIS.

Related topics

- *Geographical – Display options* on page 211
- *Geographical – KSGPL edit mode* on page 223

How to use SIS Objects

Basic concepts

SIS Objects must be configured before use. You must define your object types first. An object type is based on one of the following basic types: line (2D), line (2.5D), i.e. depth contours, area (polygon), point (2D), point (3D), image, video or HTML.

From one of the basic types, you create a new object type with a name and a definition describing how that object type shall be drawn in the map. As an example, a new object type can be coastline, which will be based on line (2D), and it may be drawn as a solid green line two pixels wide.

Once all the object types have been defined, they can be written to a file. This file can then be imported later. This means that you only have to define your object types once, later you simply import them.

You can in the **Geographical view** use the **Option** button and select **KSGPL** in the left hand tree structure to turn on/off object types to display. you can turn on/off all objects or choose which types to see.

You can add, delete and select objects in the **Geographical view** by turning the **KSGPL** objects on, and then enabling the **K** button in the frame toolbar. The **K** button turns the **Geographical view** into **KSGPL** mode and allows you to edit the objects.

Starting SIS objects

SIS Objects is started from the **Tools** menu in SIS. Select **Tools**→**Custom...**→**Objects** The following window will appear:

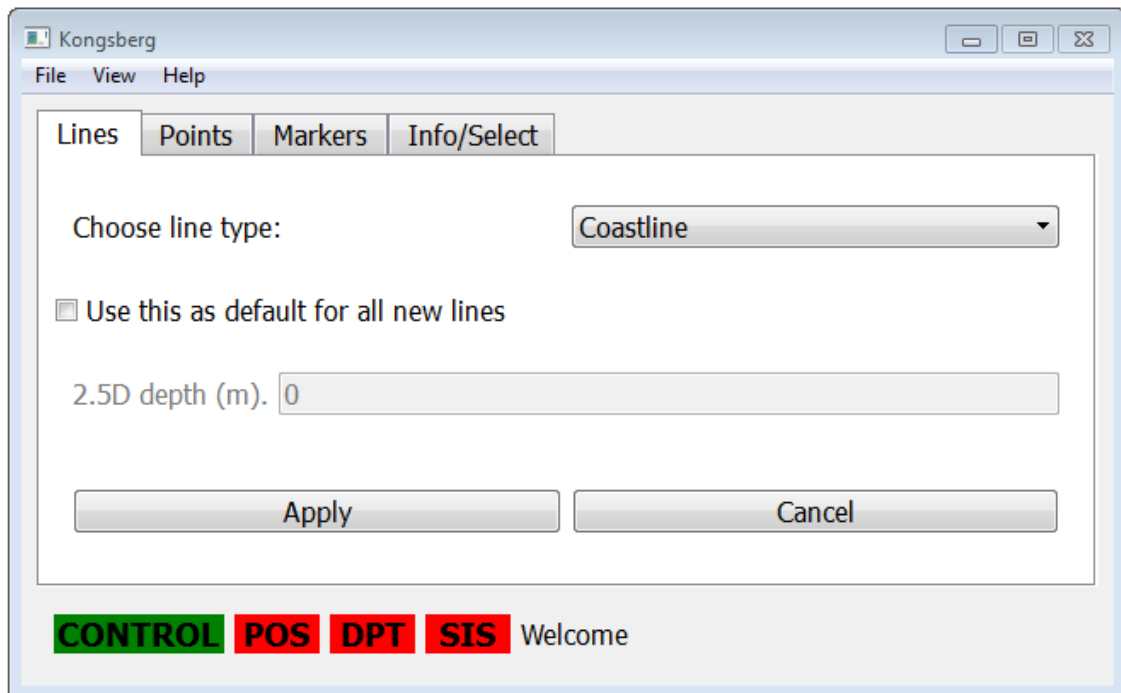

SIS Objects will automatically try to connect to current active echo sounder and the **Geographical frame**. If depths or positions are not received from the echo sounder, the buttons **DPT** and **POS** to the lower left in above figure will be red, whilst they are green when depths and positions are received. Connection to the **Geographical frame** shown by red or green button labelled **SIS**. The **SIS** button is green when connection is established. It will go red if there is no activity in the **Geographical frame** for a while, but will turn green again as soon as the view changes.

SIS Objects uses a server application to talk to the **Geographical view**. This server must be running. The button **CNT** will be green when the server is alive and well, red when it's not. If the **CNT** button is red, restart **SIS Objects**.

Adding objects

- 1 Select the **Geographical view**.
- 2 Click the **Option** button from the toolbar.
- 3 Select **KSGPL** in the left hand side tree structure.
- 4 Make sure that **KSGPL** is enabled.
- 5 Select the object types you want to see by checking the appropriate check boxes in the dialog on the right hand side.
- 6 Press the **K** button from the toolbar of the **Geographical frame** to add objects
This puts the **Geographical view** into **KSGPL** mode where you can edit objects.
- 7 Use **Right Mouse** button to pop up a menu in the **Geographical view** where you add line or point objects.
- 8 Use **Ctrl+Left Mouse** button to create the point or the line.
- 9 Press **Right Mouse** button to accept or cancel your point or line.

Lines

Once the object is created **SIS Objects** dialog will appear. If you added a line, see procedure above. There you can select which line type you want your line to be, i.e. coastline, depth contour, dryfall etc. If you know you are going to be working with the same object type for some time, like when you are adding a lot of coastlines, you can check the button **Use this type as default for all new lines** and you will not see **SIS Objects** dialog again as it will assume that all lines are of the selected type.

If the line is a 2.5D line (i.e. depth contour), you can set the depth for the line in the text field.

Press **Apply** to accept the changes.

Points

If you added a point, **SIS Objects** will look like this:

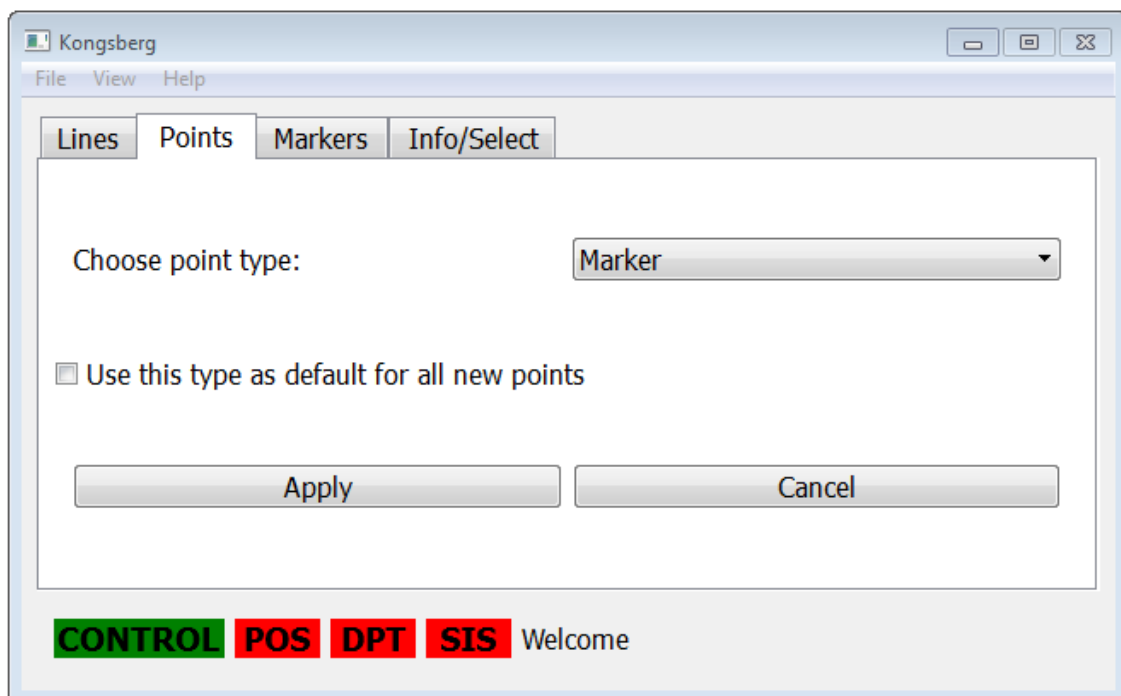

This works the same way as for lines.

- 1 Choose the point type you want to add
- 2 Make it the default for all later points if you want to add many points of the same type
- 3 Set the depth if the point type is 3D

The point type can always be **Text**. You may enter a text in the text field at the bottom of the dialog and that text will appear where you added the point in the **Geographical view**.

If the type is of **HTML** or **Video** type, the complete path to the HTML or video must be entered into the text field.

Note

Remember to put “ ” around if the path name contains spaces.

Press **Apply** to accept the changes.

Markers

You can use **Markers** if an echo sounder is attached and operational.

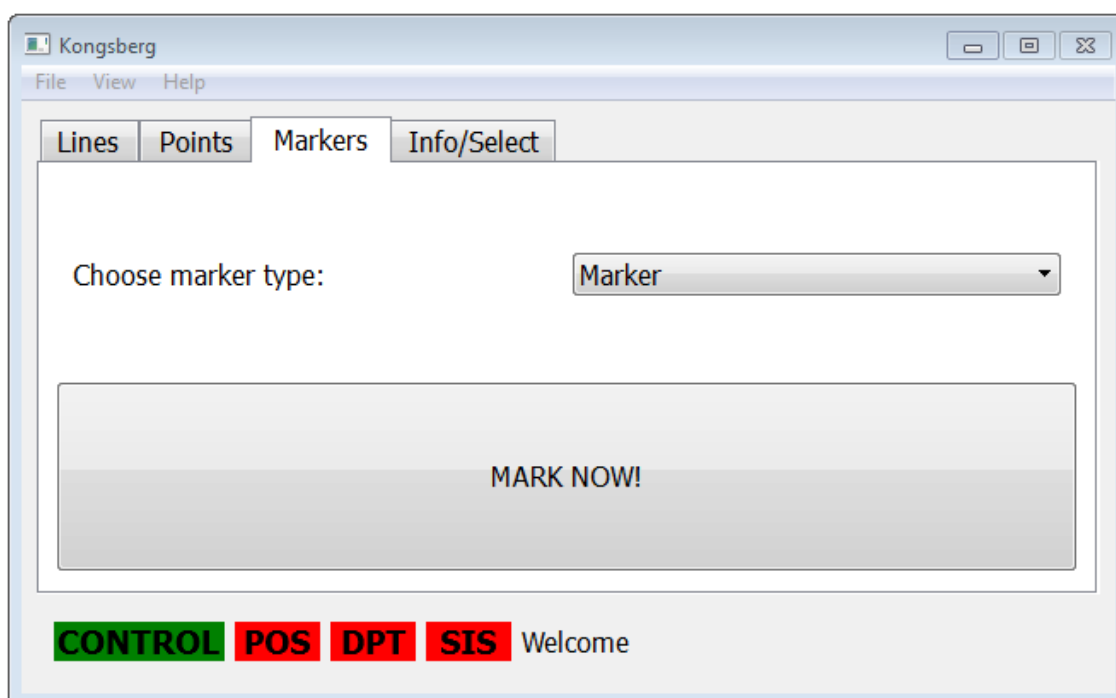

- 1 Select the tab named Markers and the above dialog will appear.
- 2 choose which **marker type** you want the marker to be.

It can be any point type except for Text.

If the type is a 2D point, only the position will be used, 3D point types use the depth below the waterline to find the z value. All these markers store the time from the position together with the data so it is possible to later correct for tide, if necessary.

When you press **MARK NOW!** the current position and the current depth will be used to create an object of the selected type, and the object will appear in the Geographical view

Info/Select

You can select object in the **Geographical View**.

- 1 Enable the **K** button.
- 2 Move the mouse over the object and press right mouse button.

The selected objects will be sent to **SIS Objects**.

You can then see the selected objects in the tab labelled **Info/Select**.

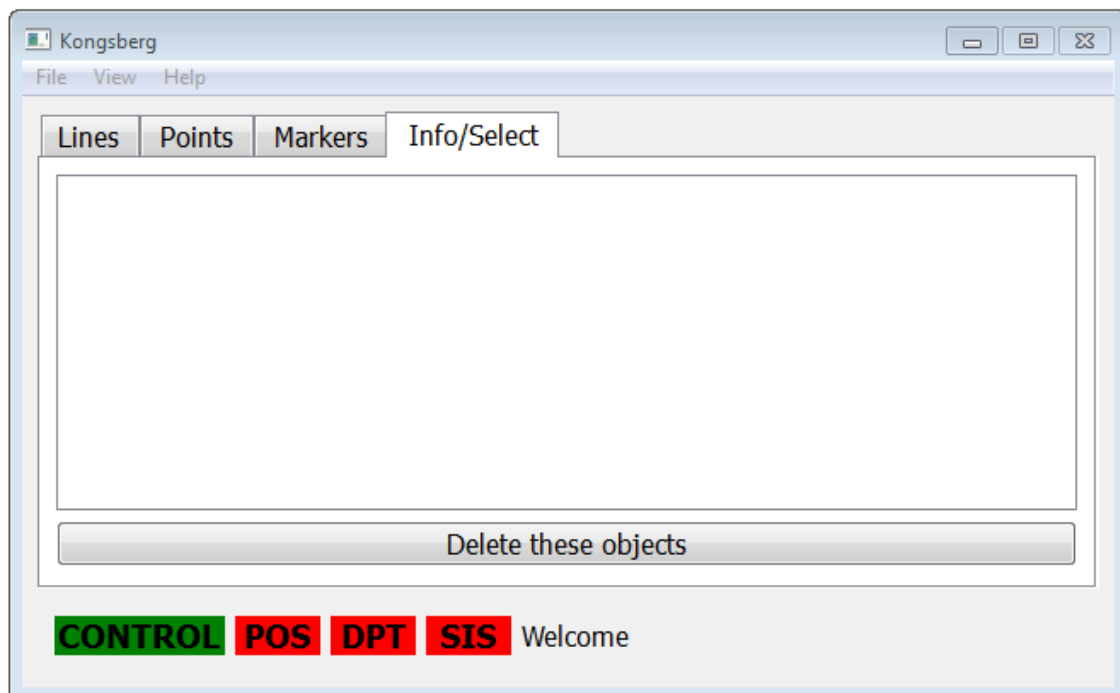

You may choose to delete the selected objects from this dialog.

Import and export of objects

You can import objects from file by pressing **File**→**Read from file...** Then you select the file with the data and the objects will appear in **SIS Objects**.

Note that this requires some synchronization with the object types in the database. Also note that if you have added objects, they may be lost if the objects in the file have the same id as your objects.

Objects can be exported to file by pressing **File**→**Write to file...** You then choose the name of the file you want to write to.

Additional information

Sometimes it may be necessary to resend all the object definitions to SIS. You do this by pressing **View**→**Update SIS with object types**. This is necessary if the object types do not appear in the **Option**→**KSGPL** list in the **Geographical View**.

Configuration of SIS Objects

In SIS Objects, select **View**→**Advanced settings** and two more tabs will appear.

Settings

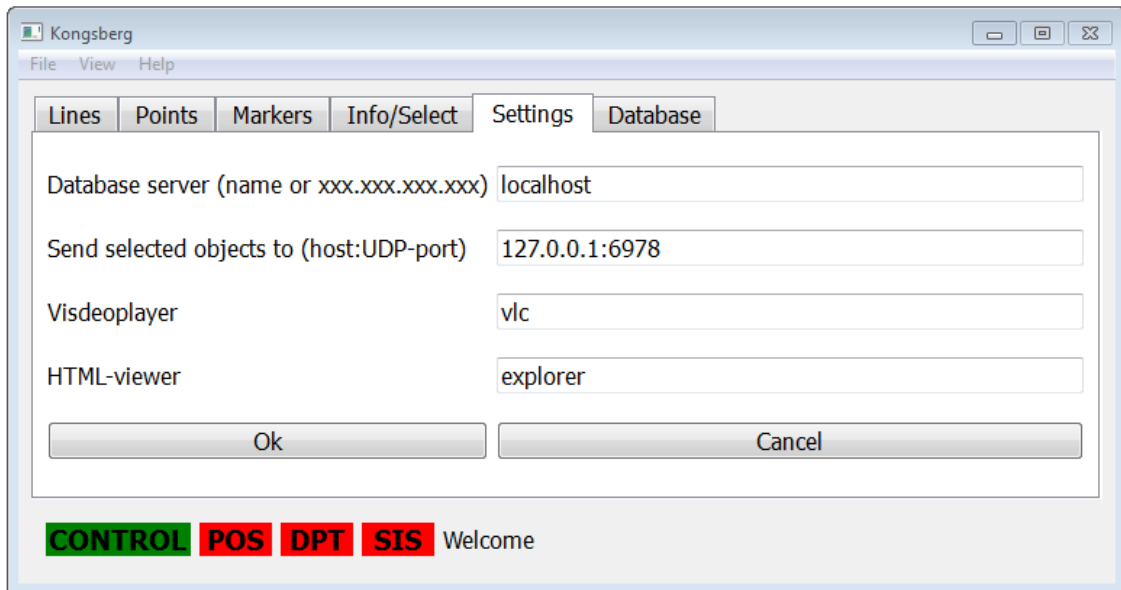

Here you can select the host where the database server is running. Note that this database is different from the one SIS uses.

The selected objects are always passed on to the host:port defined here.

If an object of video type is selected, the video file will be passed as the first argument to the video player application listed here. Note that “ ” are needed to avoid confusion with spaces in the filename.

Objects of HTML type are likewise sent to the HTML viewer listed here.

Database

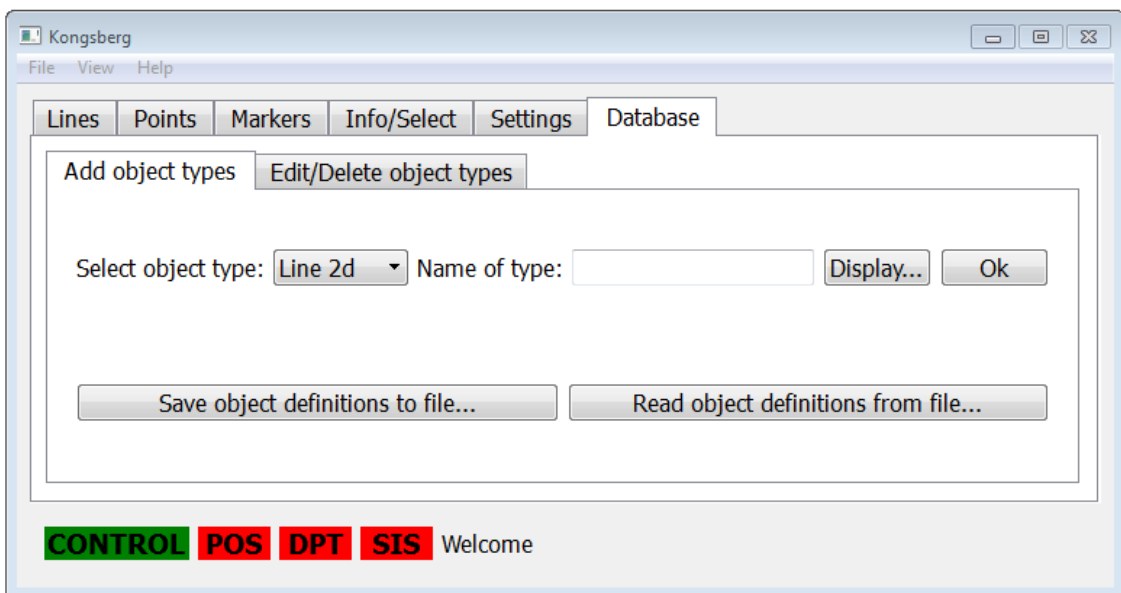

The tab named **Database** is where you define your object types.

- 1 Define the main object type in the menu **Select object type**.
Choose from Line (2D), Line (2.5D), Area, Point 2D, Point 3D and Image.
- 2 Give the object type a name, e.g. Coastline, Manual Depth, etc.
- 3 Press the **KSGPL...** button to set the parameters for how to display objects of this type.
- 4 Press **OK** to save the object type.

Different parameters which controls the display of object types:

- **Line (2D) and Line (2.5D)**

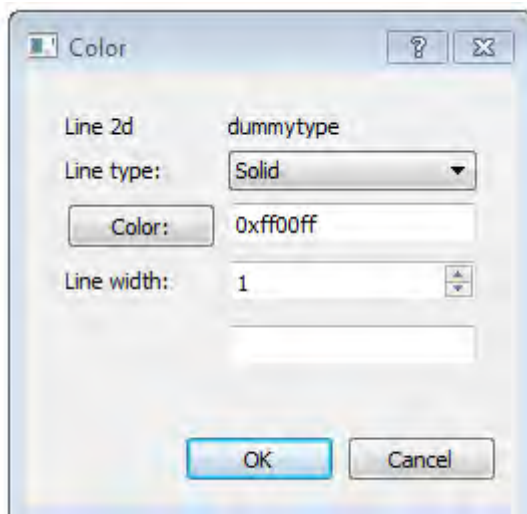

Line type can be either solid or dotted. The colour can be chosen from a palette that appears when pressing **Color....**

- **Area**

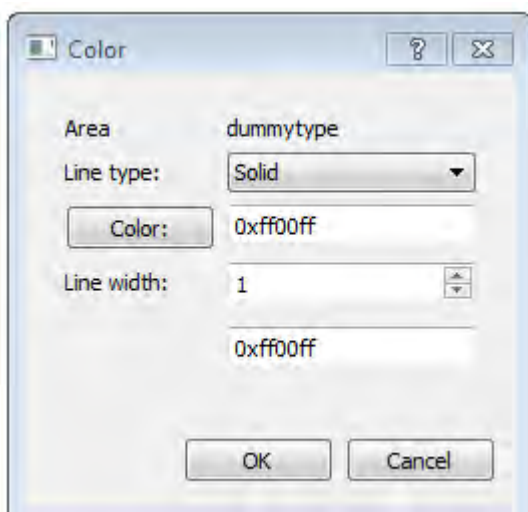

Transparency sets the transparency of the area. The fill colour is chosen, and the line type, width and colour for the surrounding polygon are also set.

- **Point 2D and Point 3D**

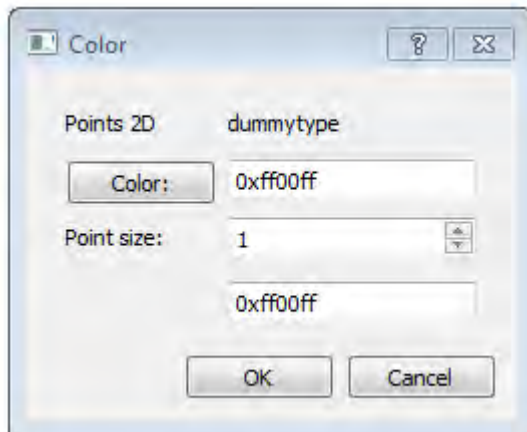

The colour and the point size in pixels are defined for 2D and 3D points.

- **Image**

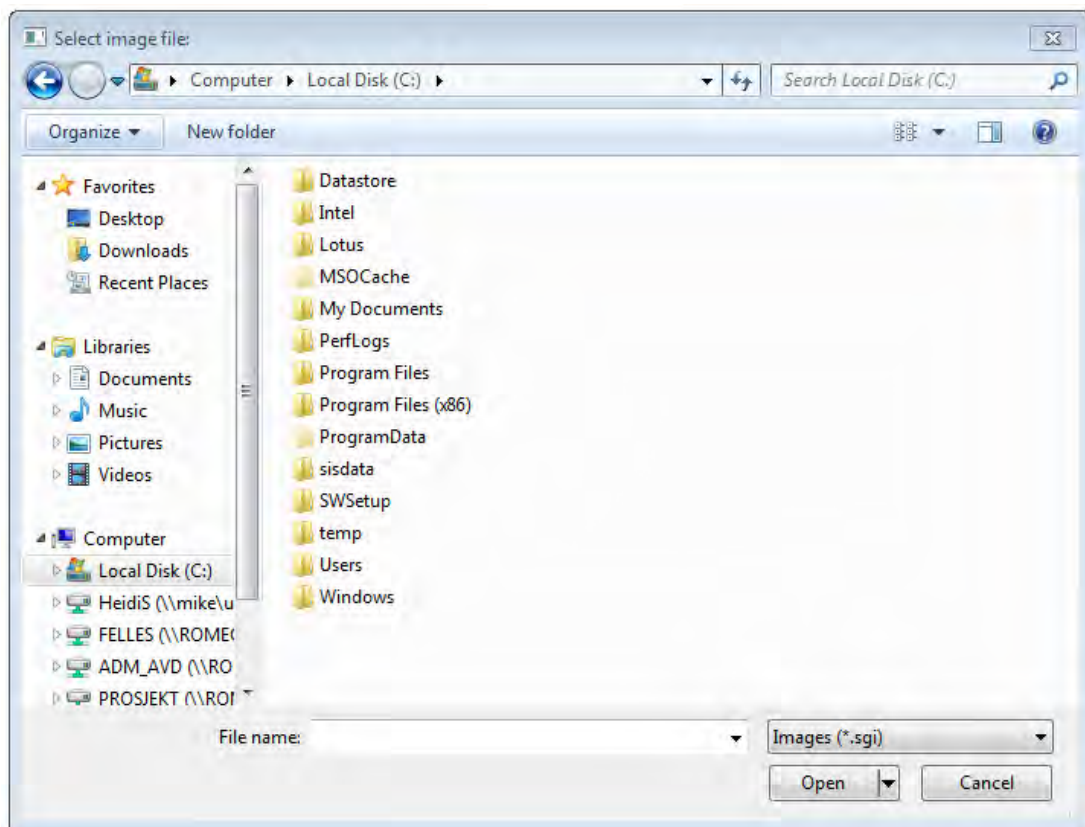

An image type is defined by which image it displays. Note that the file type is *.sgi, i.e. Silicon Graphics File Format.

- Two more types, **HTML** and **Video** can also be defined. The KSGPL for these types is the same as for a 2D point.

Object types can be saved to file by pressing **Save object definitions to file...** . Then select the filename and the object definitions are stored.

Object types can be read from file by pressing **Read object definitions from file...** . Then select the file name and the object types are loaded into the database. Note that existing object types with the same name as one in the file, will be deleted and the definition in the file will be used.

It is also possible to delete and edit object types. Note that deleting an object type, automatically deletes all objects of that type as well.

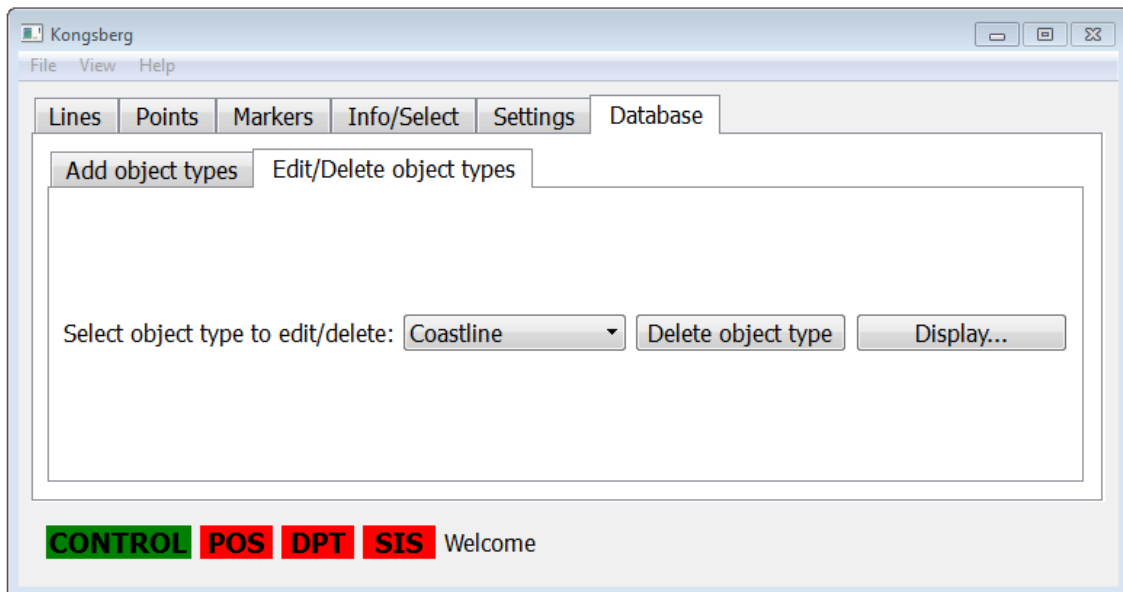

Press **Delete** object type to delete the object type. Note that the objects will still be displayed in the Geographical View until SIS is restarted. Press **KSGPL** to change the way the object type is displayed; line type solid/dotted, line with, point type, etc.

Technical references

SIS Objects cannot be used if some other application is using KSGPL at the same time.

Selected object datagram format

When the operator selects an object in SIS GeoView, SIS Objects will send information about the selected object to the UDP host:port defined. The format is:

```
0 27 MyPoint 59.32114415 18.10475915 2008-04-11T15:01:08
```

- First item in the message is the basic type (see the database definition file below), then the database id, then the name of the type as defined by the operator. The rest is depended upon the basic type. For 0 above, the position (latitude in degrees and longitude in degrees) and time is given as shown.

```
1 6 Kaidybde 59.32112343 18.08118750 33.00000000
2008-04-11T09:29:14
```

- 3D points also have the depth after the position.

```
8 23 Nyheter "usatoday.com" 59.32681627 18.08416633
```

- HTML objects have the web-address before the position.

```
7 9 MyVideo "C:/12angrymen_trailer.mov" 59.32295218 18.08355627
```

- Video objects have the path to the video. Note that the directory separator is /, not \.

```
5 8 bilde 59.32028155 18.09755164
```

- An image

```
4 7 59.32223918 18.08571897 Survey this area with EM3002
```

- Text object

```
2 3 TopasTracline -999999.000000 2008-04-15T12:46:50
-9 -9 59.33072409 18.08834272 59.32890464 18.10877874
59.32121934 18.11104439 59.32034466 18.13219046
59.31490604 18.13276897 59.31145264 18.11383809
59.30930524 18.09206320 59.31259050 18.07563680
```

- A 2D line has -999999.000000 as depth, and -9 -9 after the timestamp. The positions are latitude and longitude in degrees.

```
3 33 Dybdekurve 55.800000 2008-04-16T12:34:06
-9 -9 59.31115771 18.0 1625823
59.29008772 18.04918203
59.28745531 18.11027601
```

- A 2.5D line has a depth different from -999999.000000

Right before or right after a line/polygon object, this message is sent:

```
PICKED_POS 59.18845234 18.23549827 PICKED_POS_DONE
```

This message contains the exact position where the operator pressed the mouse when he selected the line. This can be used for accurate positioning within the selected line.

File formats

There are two file formats used by SIS Objects. The files are ascii XML files, and the XML format is defined using XML schemas, aka.xsd files.

There are three schema definitions:

- Objects
- Object type definitions
- Database definitions

The formats of these schema definitions are described in the following.

Objects

```
<rule:schema xmlns:rule="http://www.w3.org/2001/XMLSchema">
  <rule:annotation>
    <rule:documentation xml:lang="en">
      Object file for SIS Objects
      Copyright: Kongsberg
    </rule:documentation>
  </rule:annotation>

  <rule:annotation>
    <rule:documentation xml:lang="en">
      This is the structure of the definition file.
      First there is a header, then a list of object types
    </rule:documentation>
  </rule:annotation>
  <rule:element name="ObjectFile">
    <rule:complexType>
      <rule:sequence>
```

```

        <rule:element name="FileVersion" type="rule:integer"/>
        <rule:element name="Created" type="rule:dateTime"/>
        <rule:element name="ObjectFileItem" type="ObjectFileUnion"
            minOccurs="0" maxOccurs="unbounded"/>
    </rule:sequence>
</rule:complexType>
</rule:element>

<rule:annotation>
    <rule:documentation xml:lang="en">
        Point 2D
    </rule:documentation>
</rule:annotation>
<rule:group name="Point2D">
    <rule:sequence>
        <rule:element name="Point2D_ID" type="rule:integer"/>
        <rule:element name="Point2D_Objtype" type="rule:string"/>
        <rule:element name="Point2D_Time" type="rule:dateTime"
            minOccurs="0" maxOccurs="1"/>
        <rule:element name="Point2D_NorthDegr" type="rule:double"/>
        <rule:element name="Point2D_EastDegr" type="rule:double"/>
    </rule:sequence>
</rule:group>

<rule:annotation>
    <rule:documentation xml:lang="en">
        Point 3D
    </rule:documentation>
</rule:annotation>
<rule:group name="Point3D">
    <rule:sequence>
        <rule:element name="Point3D_ID" type="rule:integer"/>
        <rule:element name="Point3D_Objtype" type="rule:string"/>
        <rule:element name="Point3D_Time" type="rule:dateTime"
            minOccurs="0" maxOccurs="1"/>
        <rule:element name="Point3D_NorthDegr" type="rule:double"/>
        <rule:element name="Point3D_EastDegr" type="rule:double"/>
        <rule:element name="Point3D_DepthMeters" type="rule:double"/>
    </rule:sequence>
</rule:group>

<rule:annotation>
    <rule:documentation xml:lang="en">
        Line, 2D. Also areas are created here; typename defines how
        this line is used.
    </rule:documentation>
</rule:annotation>
<rule:group name="Line">
    <rule:sequence>
        <rule:element name="Line_ID" type="rule:integer"/>
        <rule:element name="Line_Time" type="rule:dateTime"
            minOccurs="0" maxOccurs="1"/>
        <rule:element name="Line_Coordinates2D" type="Coordinates2D"
            minOccurs="2" maxOccurs="unbounded"/>
        <rule:element name="Line_Objtype" type="rule:string"/>
    </rule:sequence>
</rule:group>

```

```

<rule:annotation>
  <rule:documentation xml:lang="en">
    Line 2.5D
  </rule:documentation>
</rule:annotation>
<rule:group name="Line25D">
  <rule:sequence>
    <rule:element name="Line25D_ID" type="rule:integer"/>
    <rule:element name="Line25D_Time" type="rule:dateTime"
      minOccurs="0" maxOccurs="1"/>
    <rule:element name="Line25D_Depth" type="rule:double"/>
    <rule:element name="Line25D_Coordinates2D" type="Coordinates2D"
      minOccurs="0" maxOccurs="unbounded"/>
    <rule:element name="Line25D_Objtype" type="rule:string"/>
  </rule:sequence>
</rule:group>

<rule:annotation>
  <rule:documentation xml:lang="en">
    Text
  </rule:documentation>
</rule:annotation>
<rule:group name="Text">
  <rule:sequence>
    <rule:element name="Text_ID" type="rule:integer"/>
    <rule:element name="Text_Objtype" type="rule:string"/>
    <rule:element name="Text_Time" type="rule:dateTime"
      minOccurs="0" maxOccurs="1"/>
    <rule:element name="Text_NorthDegr" type="rule:double"/>
    <rule:element name="Text_EastDegr" type="rule:double"/>
    <rule:element name="Text_text" type="rule:string"/>
  </rule:sequence>
</rule:group>

<rule:annotation>
  <rule:documentation xml:lang="en">
    Image
  </rule:documentation>
</rule:annotation>
<rule:group name="Image">
  <rule:sequence>
    <rule:element name="Image_ID" type="rule:integer"/>
    <rule:element name="Image_Objtype" type="rule:string"/>
    <rule:element name="Image_Time" type="rule:dateTime"
      minOccurs="0" maxOccurs="1"/>
    <rule:element name="Image_NorthDegr" type="rule:double"/>
    <rule:element name="Image_EastDegr" type="rule:double"/>
  </rule:sequence>
</rule:group>

<rule:annotation>
  <rule:documentation xml:lang="en">
    Video
  </rule:documentation>
</rule:annotation>
<rule:group name="Video">
  <rule:sequence>
    <rule:element name="Video_ID" type="rule:integer"/>
    <rule:element name="Video_Objtype" type="rule:string"/>
    <rule:element name="Video_Time" type="rule:dateTime"
      minOccurs="0" maxOccurs="1"/>
    <rule:element name="Video_NorthDegr" type="rule:double"/>
    <rule:element name="Video_EastDegr" type="rule:double"/>
    <rule:element name="Video_path" type="rule:string"/>
  </rule:sequence>
</rule:group>

```

```

<rule:annotation>
  <rule:documentation xml:lang="en">
    Html
  </rule:documentation>
</rule:annotation>
<rule:group name="Html">
  <rule:sequence>
    <rule:element name="Html_ID" type="rule:integer"/>
    <rule:element name="Html_Objtype" type="rule:string"/>
    <rule:element name="Html_Time" type="rule:dateTime"
      minOccurs="0" maxOccurs="1"/>
    <rule:element name="Html_NorthDegr" type="rule:double"/>
    <rule:element name="Html_EastDegr" type="rule:double"/>
    <rule:element name="Html_path" type="rule:string"/>
  </rule:sequence>
</rule:group>

<rule:annotation>
  <rule:documentation xml:lang="en">
    This is a union of all object types.
  </rule:documentation>
</rule:annotation>
<rule:complexType name="ObjectFileUnion">
  <rule:sequence>
    <rule:choice>
      <rule:group ref="Line"/>
      <rule:group ref="Line25D"/>
      <rule:group ref="Point2D"/>
      <rule:group ref="Point3D"/>
      <rule:group ref="Image"/>
      <rule:group ref="Text"/>
      <rule:group ref="Video"/>
      <rule:group ref="Html"/>
    </rule:choice>
  </rule:sequence>
</rule:complexType>

<rule:annotation>
  <rule:documentation xml:lang="en">
    2D coordinate
  </rule:documentation>
</rule:annotation>
<rule:complexType name="Coordinates2D">
  <rule:sequence>
    <rule:element name="NorthDegr" type="rule:double"/>
    <rule:element name="EastDegr" type="rule:double"/>
  </rule:sequence>
</rule:complexType>
</rule:schema>

```

Object type definitions

```

<rule:schema xmlns:rule="http://www.w3.org/2001/XMLSchema">

  <rule:annotation>
    <rule:documentation xml:lang="en">
      Object definition file for SIS Objects
      Copyright: Kongsberg
    </rule:documentation>
  </rule:annotation>

  <rule:annotation>
    <rule:documentation xml:lang="en">
      This is the structure of the definition file.
      First there is a header, then a list of object types
    </rule:documentation>
  </rule:annotation>
  <rule:element name="ObjectDefinitionFile">
    <rule:complexType>

```

```

        <rule:sequence>
            <rule:element name="FileVersion" type="rule:integer"/>
            <rule:element name="Created" type="rule:dateTime"/>
            <rule:element name="ObjectDefinition" type="ObjectUnion"
                minOccurs="0" maxOccurs="unbounded"/>
        </rule:sequence>
    </rule:complexType>
</rule:element>

<rule:annotation>
    <rule:documentation xml:lang="en">
        Line 2D
    </rule:documentation>
</rule:annotation>
<rule:group name="Line2D">
    <rule:sequence>
        <rule:element name="ObjectTypeNameLine2D" type="rule:string"/>
        <rule:element name="LineType" type="rule:string"/>
        <rule:element name="Width" type="rule:integer"/>
        <rule:element name="Color" type="rule:string"/>
    </rule:sequence>
</rule:group>

<rule:annotation>
    <rule:documentation xml:lang="en">
        Line 2.5D
    </rule:documentation>
</rule:annotation>
<rule:group name="Line25D">
    <rule:sequence>
        <rule:element name="ObjectTypeNameLine25D" type="rule:string"/>
        <rule:element name="LineType" type="rule:string"/>
        <rule:element name="Width" type="rule:integer"/>
        <rule:element name="Color" type="rule:string"/>
    </rule:sequence>
</rule:group>

<rule:annotation>
    <rule:documentation xml:lang="en">
        Area
    </rule:documentation>
</rule:annotation>
<rule:group name="Area">
    <rule:sequence>
        <rule:element name="ObjectTypeNameArea" type="rule:string"/>
        <rule:element name="LineType" type="rule:string"/>
        <rule:element name="Width" type="rule:integer"/>
        <rule:element name="AreaColor" type="rule:string"/>
        <rule:element name="AreaTransparency" type="rule:integer"/>
        <rule:element name="Color" type="rule:string"/>
    </rule:sequence>
</rule:group>

<rule:annotation>
    <rule:documentation xml:lang="en">
        Area 3D
    </rule:documentation>
</rule:annotation>
<rule:group name="Area3D">
    <rule:sequence>
        <rule:element name="ObjectTypeNameArea3D" type="rule:string"/>
        <rule:element name="LineType" type="rule:string"/>
        <rule:element name="Width" type="rule:integer"/>
        <rule:element name="AreaColor" type="rule:string"/>
        <rule:element name="AreaTransparency" type="rule:integer"/>
        <rule:element name="Color" type="rule:string"/>
    </rule:sequence>
</rule:group>

```



```

<rule:annotation>
  <rule:documentation xml:lang="en">
    Point 2D
  </rule:documentation>
</rule:annotation>
<rule:group name="Point2D">
  <rule:sequence>
    <rule:element name="ObjectTypeNamePoint2D" type="rule:string"/>
    <rule:element name="Width" type="rule:integer"/>
    <rule:element name="Color" type="rule:string"/>
  </rule:sequence>
</rule:group>

<rule:annotation>
  <rule:documentation xml:lang="en">
    Point 3D
  </rule:documentation>
</rule:annotation>
<rule:group name="Point3D">
  <rule:sequence>
    <rule:element name="ObjectTypeNamePoint3D" type="rule:string"/>
    <rule:element name="Width" type="rule:integer"/>
    <rule:element name="Color" type="rule:string"/>
  </rule:sequence>
</rule:group>

<rule:annotation>
  <rule:documentation xml:lang="en">
    Image
  </rule:documentation>
</rule:annotation>
<rule:group name="Image">
  <rule:sequence>
    <rule:element name="ObjectTypeNameImage" type="rule:string"/>
    <rule:element name="ImagePath" type="rule:string"/>
  </rule:sequence>
</rule:group>

<rule:annotation>
  <rule:documentation xml:lang="en">
    Point with video
  </rule:documentation>
</rule:annotation>
<rule:group name="Video">
  <rule:sequence>
    <rule:element name="ObjectTypeNameVideo" type="rule:string"/>
    <rule:element name="Width" type="rule:integer"/>
    <rule:element name="Color" type="rule:string"/>
  </rule:sequence>
</rule:group>

<rule:annotation>
  <rule:documentation xml:lang="en">
    Point with html
  </rule:documentation>
</rule:annotation>
<rule:group name="Html">
  <rule:sequence>
    <rule:element name="ObjectTypeNameHtml" type="rule:string"/>
    <rule:element name="Width" type="rule:integer"/>
    <rule:element name="Color" type="rule:string"/>
  </rule:sequence>
</rule:group>

<rule:annotation>
  <rule:documentation xml:lang="en">
    This is a union of all object types.
  </rule:documentation>
</rule:annotation>
<rule:complexType name="ObjectUnion">

```

```

    <rule:sequence>
      <rule:choice>
        <rule:group ref="Line2D"/>
        <rule:group ref="Line25D"/>
        <rule:group ref="Area"/>
        <rule:group ref="Area3D"/>
        <rule:group ref="Point2D"/>
        <rule:group ref="Point3D"/>
        <rule:group ref="Image"/>
        <rule:group ref="Video"/>
        <rule:group ref="Html"/>
      </rule:choice>
    </rule:sequence>
  </rule:complexType>

```

```
</rule:schema>
```

Database definition

Here is the sql file used to define the database used by SIS Objects. The connection to the database is assumed to be an ODBC-connection named KSGPLDB where the database name is KSGPLDB. The user is KSGPL and the password is simrad0. If objects are added to the database outside of SIS Objects, i.e. by an external application, a datagram can be sent to force SIS Objects to redraw all objects so that also the new object can be seen. Then send this datagram on UDP to

```
localhost:5688 $KSSIS,8802\n\r
```

```

/* ----- */
/*
/* Create tables and views for KSGPLDB used by SIS_objects
/*
/* This file is for SIS 3.6 and used by SIS_Object
/*
/* For later releases new files: ksgpldef_v*.sql has to be made
/*
/* KSGPLDB runs on a Postgres server on both Windows and Linux
/*
/* Terje Pedersen Mar-2008
/*
/* Berit Horvei 28-Mar-2008
/* ----- */

/* Don't drop the tables, in later SIS releases than SIS 3.6, the database can be kept*/
/* The user can select to delete the database*/
/* drop view if exists line25d;
drop view if exists text3d;
drop table if exists boundingbox;
drop table if exists timed;
drop table if exists image;
drop table if exists texts;
drop table if exists polygon;
drop table if exists polygon3D;
drop table if exists line2d;
drop table if exists video;
drop table if exists html;
drop table if exists z3;
drop table if exists timed;
drop table if exists point2d;
drop table if exists point3d;
drop table if exists keys;
drop table if exists name_type; */

```

```

/* This is the name of the type, i.e. depthcontour, coastline, etc.
type = 0: point2d
type = 1: point3d
type = 2: line2d
type = 3: line25d
type = 4: texts
type = 5: image
type = 6: polygon3D
type = 7: video
type = 8: html
type = 9: polygon2D
*/

create table ksgpl_version (current_version int NOT NULL,
current_versionname varchar(20) NOT NULL);
insert into ksgpl_version (current_version, current_versionname) values (1,'1.0');

create table name_type (name varchar(200) unique primary key, obj_id int unique not null,
type int not null check(type >= 0) check(type <= 9), ksgpl varchar(200) not null);

/* All objects in the database MUST have a unique integer identifier.
Therefore all objects must link to the table keys for their id.
For each id there must be a connection to the name_type. */
create table keys (id int unique primary key, name varchar(200) not null,
foreign key(name) references name_type);

/* 2D points go here. They are linked to name_type, of course. */
create table point2d (id int unique primary key, northDegr double precision not null,
eastDegr double precision not null, foreign key(id) references keys);

/* 3D points. */
create table point3d (id int unique primary key, northDegr double precision not null,
eastDegr double precision not null, zMeters double precision not null,
foreign key(id) references keys);

/* 2D lines. Note that lines may be very long, and the coordinates are stored in a character string.
Because this string may be longer than 2048, the length of one row in this table,
several rows may be used for one line.
Each line is thus split into segments, and when put together, all the coordinates
from all the segments will be the whole line.
Note that it is the responsibility of the programmer to put the coordinates in the right segments.*/
create table line2d (id int, sequence smallint not null, coordinates varchar(2048) not null,
foreign key(id) references keys);

/*2.5D lines are line2d where the id has a corresponding id in z25d. */

/* Polygon, note that this polygon is 2D.
This is only a reference to line2d */
create table polygon (id int unique primary key, foreign key(id) references keys);

/* Polygon, note that this polygon is 3D, which only means the the coordinates contain z as well */
create table polygon3D (id int unique primary key, foreign key(id) references keys);

/* Here is the depth value of the 2.5D lines, z-value for text (if present) */
create table z3d (id int unique primary key, zMeters double precision not null,
foreign key(id) references keys);

/* Here are texts. They may be 3D in which case they have a reference to z25d. */
create table texts (id int unique primary key, northDegr double precision not null,
eastDegr double precision not null, text varchar(200) not null, foreign key(id) references keys);

/* Images to be displayed goes here */
create table image (id int unique primary key, northDegr double precision not null,
eastDegr double precision not null, foreign key(id) references keys);

/* Videos goes here */
create table video (id int unique primary key, northDegr double precision not null,
eastDegr double precision not null, path varchar(500) not null, foreign key(id) references keys);

```

```
/* HTML-pages goes here */
create table html (id int unique primary key, northDegr double precision not null,
  eastDegr double precision not null, path varchar(500) not null, foreign key(id) references keys);

/* Some objects may be registred with a timestamp.
  If so, the timestamp is here. */
create table timed (id int unique primary key, yyymmdd int not null, hhmmss int not null,
  foreign key(id) references keys);

/* To find objects in an area more easily, a bounding box for lines and areas are created */
create table boundingbox(id int unique primary key, minNorthDegr double precision not null,
  minEastDegr double precision not null, maxNorthDegr double precision not null, '
  maxEastDegr double precision not null, foreign key(id) references keys);

/* View to find all 2.5D lines */
create view line25d as select z3d.id, sequence, coordinates, zMeters from line2d,
  z3d where line2d.id = z3d.id;

/* 3D texts */
create view text3d as select z3d.id, northDegr, eastDegr, zMeters from texts,
  z3d where texts.id = z3d.id;

/* This table contains two files, the schema files used to define the xml-format
  for object types and objects. */
create table xsd (id int /* 1 means object types, 2 means object definition schema */
  not null, xsd_schema varchar (20000) not null);
```

Logging utilities

Any data that is input across the computer network to either the SIS computer or to the PU can be logged using the utilities described in this section.

Topics

- *Logging of input on SIS sockets* on page 435
- *Logging of input on PU sockets* on page 438

Logging of input on SIS sockets

This is a feature primarily intended for support and maintenance activities, e.g. to verify reception of input on sockets and further to validate the received data content.

The logged input data is presented in an hexadecimal format with an additional ASCII representation where all unprintable characters are represented by a dot.

There are two logging alternatives:

- *SIS Data Logger for SIS sockets logging* on page 435
- *Command based SIS sockets logging* on page 436

SIS Data Logger for SIS sockets logging

This alternative for logging of incoming data on a SIS socket is based on the use of an separate utility program, *SIS Data Logger*:

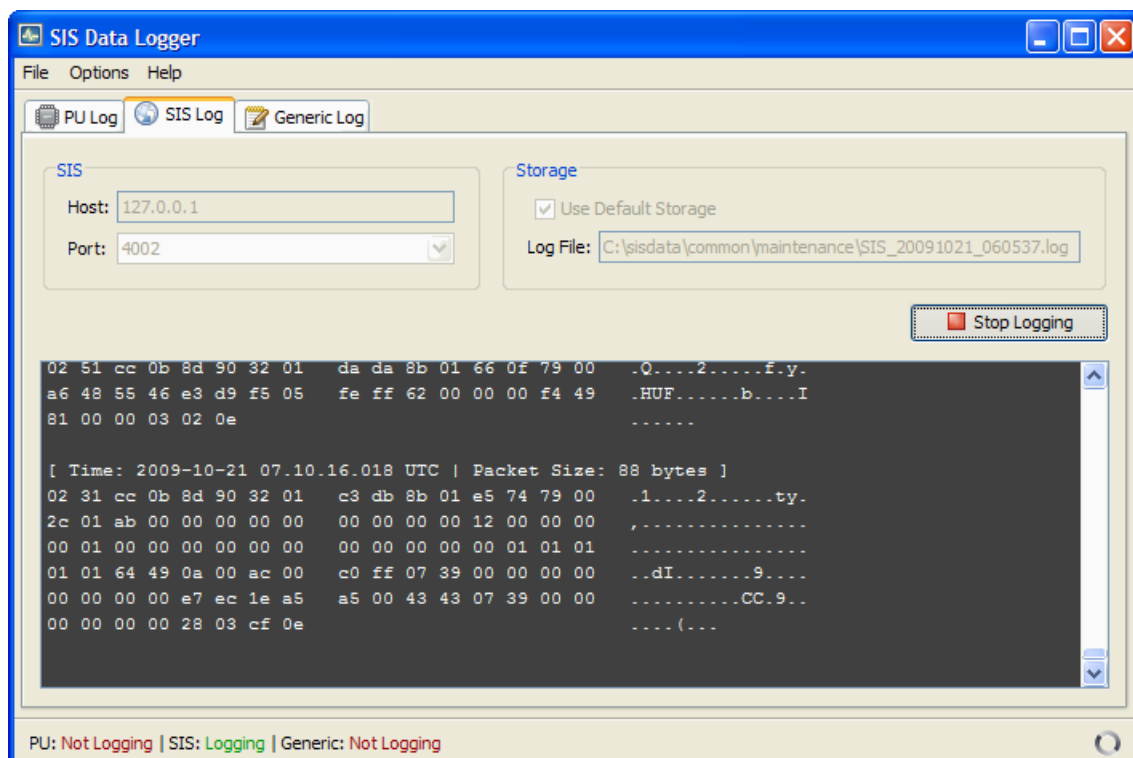

The program is started from **Tools**→**Custom...**→**SIS Data Logger**.

The program will send a command to the relevant socket for start and stop logging. When logging is active the data received on the SIS socket will be re-transmitted out on another socket and received by the logger program. The logger program is responsible for decoding, displaying and storing the data.

In contrast to alternative 2 below the operator may now get a running update of the received data in the display while the data is being logged.

The following input parameters and controls are available:

- **Host:** This is the IP address of the HWS where SIS is residing. Currently this should always be the 127.0.0, i.e. the *SIS Data Logger* program must always run on the same computer as SIS.
- **Port:** This is a drop down list of some fixed SIS sockets. In addition the user may manually enter a SIS socket, however see *Remarks about SIS sockets* on page 437 below.

- **Use default storage:**

When selected (ticked) a predefined set of storage options are used:

- The default directory is:
`...sisdata/common/maintenance`
- The default file name is:
`SIS_yyyymmdd_hhmmss.log`
where the date and time is the UTC time when logging is started.

When the operator un-ticks this selection a pop-up is displayed allowing the user to select an alternative storage location and a file name. Note that if the file already exists the new logged information will be appended to the existing file.

- **Log File:** This element contains currently selected storage folder and is used for display only.
- **Log button:** The logging operation is turned on and off on the set socket using the log button.

When logging is active all user selections are inactive (i.e. gray coloured). To change the host and port settings as well as the storage settings the logging must be turned off.

- **Options**→**Show Datagram Prefix** is used to turn the info line printed at the head of each datagram packet on or off.

The info line contains packet size and a time tag.

Command based SIS sockets logging

This alternative is a low level solution based on internal SIS functionality for decoding and storing received data. No running update of logged data is available. This is in contrast to alternative 1 in *SIS Data Logger for SIS sockets logging* on page 435 which uses an external program for this purpose.

```

LoggedInput.txt - WordPad
File Edit View Insert Format Help
[Icons]
Packet size: 52
02 52 b8 0b eb 8e 32 01 de 4e 30 01 1f 00 79 00 .R÷.%Z2.èNO...y.
00 00 00 00 01 0e 01 00 03 00 00 19 96 00 0f 00 .....-...
00 0f a0 1e 0a 02 2c 01 00 41 80 41 2c 01 00 00 ..ÿ...A.A,...
ff 03 bb 08 ~.

Packet size: 27
24 4b 53 53 49 53 2c 36 33 2c 33 30 30 30 2c 31 $KSSIS,63,3000,1
32 31 2c 31 2c 31 2c 31 0a 0d 00 21,1,1,1...

Packet size: 116
02 50 b8 0b eb 8e 32 01 b6 4f 30 01 08 00 79 00 .P÷.%Z2.òOO...y.
6f 60 53 46 3d 86 f5 05 7b 01 ff ff ff ff f3 4e o`SF=Àä.{~~~~cN
81 4e 48 55 47 47 41 2c 30 35 33 32 30 31 2e 35 .NHUGGA,053201.5
35 2c 35 38 35 39 2e 36 30 37 38 38 36 39 2c 4e 5,5859.6078869,N
2c 30 30 39 35 39 2e 38 36 30 35 39 30 34 2c 45 ,00959.8605904,E
2c 33 2c 30 38 2c 31 2e 39 2c 30 2e 30 2c 4d 2c ,3,08,1.9,0.0,M,
30 2e 30 2c 4d 2c 30 2e 30 2c 30 30 30 0d 0a 0.0,M,0.0,0000..
00 03 c5 1d ..□.
For Help, press F1

```

The logging activity is started or stopped by sending the relevant socket a command message.

A perl script, *portlog.pl*, has been implemented to assist the operator in sending these commands. The *portlog.pl* script is found in the SIS installation *...bin* directory.

To run the *portlog.pl* script open a command window and start the script using the following syntax:

```
portlog <port no> <ON or OFF> <dir name> <file name>
```

Where:

- <port no> is the SIS port to log
- <ON or OFF> turns logging on or off respectively.
- <dir name> is optional. This is the directory used to store the logged file.
- <file name> is optional. This is the name of the logged file.

e.g.: `portlog 4001 ON`

If the directory and/or file names are omitted the following default values will be used:

- The default directory is:
`...sisdata/common/maintenance`
- The default file name is:
`SIS_Input_yyyymmdd_hhmmss.log`
where the date and time is the UTC time when logging is started.

Remarks about SIS sockets

Note that the sockets used by SIS are of two types:

- Fixed sockets used by invariant SIS modules (like SIS main GUI, CCU etc.)
- Sockets allocated dynamically when new echo sounders are detected for the first time

In some cases the operators may also specify ports dynamically for e.g. logging purposes. The former (fixed) type may use permanently allocated port numbers whereas the latter type uses port numbers allocated sequentially from a set start point (currently 16000).

The following are some standard fixed and explicitly defined port numbers:

- Port 4001 is used by the SIS module called CCU for receiving messages from other SIS modules and in addition the following external input:
 - SSP datagrams (i.e. S00–S53 currently) containing sound velocity and CTD profiles
 - \$KSSIS,80 with sound velocity at transducer
 - \$ATIDE datagrams with tide
 - R20 remote datagram
- Port 4002 is used by SIS main GUI for receiving messages from other SIS modules, in addition to the following external input:
 - R00, R10, R12 remote datagrams for controlling SIS pinging and logging
 - Port 5602 is used for Applanix PosMV TrueHeave logging. See **Runtime parameters→GPS and Delayed Heave**
- Port explicitly defined by user for Seapath Real Heave logging. See **Runtime parameters→GPS and Delayed Heave**.
- Port explicitly defined by user for Seapath RTCM logging. See **Runtime parameters→GPS and Delayed Heave**.

Note

Dynamically allocated port numbers associated with specific echo sounders are defined in the SIS database and requires specialist knowledge to be found. They are therefore as a consequence omitted in this description.

More information

- *GPS and delayed heave* on page 323

Logging of input on PU sockets

This feature is primarily intended for support and maintenance activities e.g. to verify reception of input on PU sockets and further to validate the received data content.

The logged input data is presented in an hexadecimal format with an additional ASCII representation where all unprintable characters are represented by a dot.

Logging of PU sensor input is only available on the new generation of echo sounders:

- EM 122
- EM 302
- EM 710
- EM 2040
- EM 2040C

- EM 3002

Note

Always remember to turn logging off when finished. No automatic shut off is provided. Neglecting to terminate logging will increase the load on the PU and HWS system and the disk capacity for storage of logged data will suffer.

SIS Data Logger for PU sockets

This alternative for logging of incoming data on a SIS socket is based on the use of an separate utility program, *SIS Data Logger*:

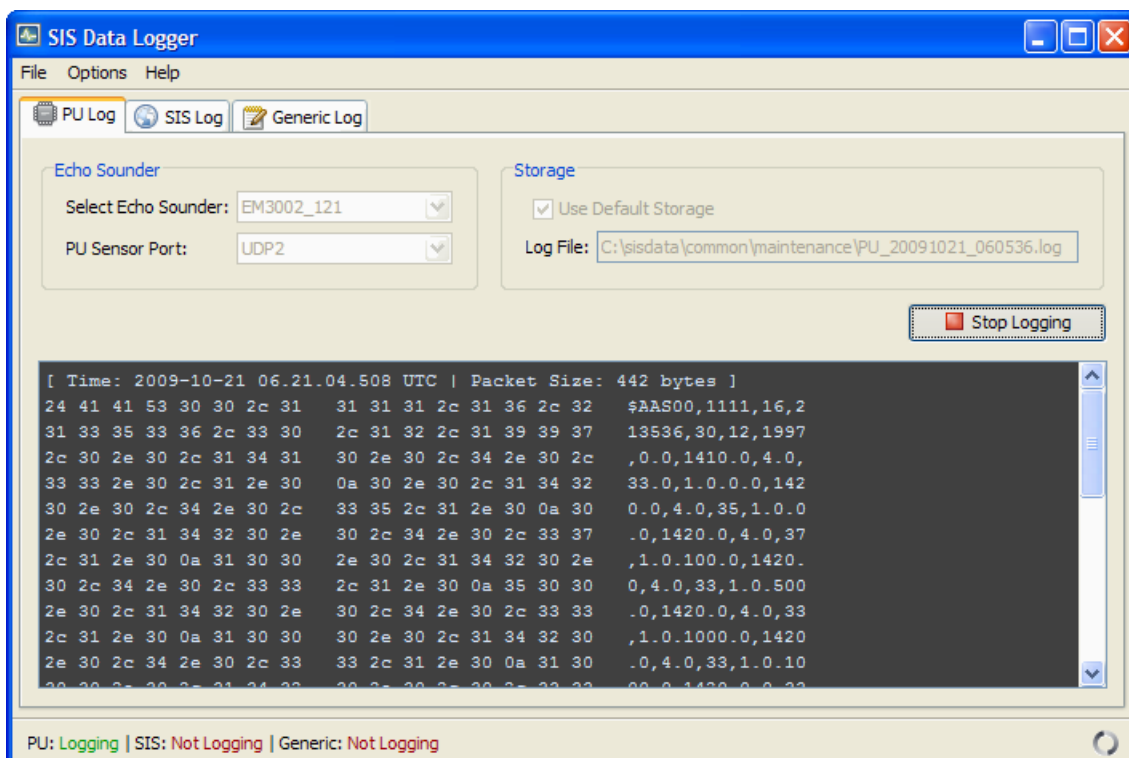

The program is started from SIS using **Tools**→**Custom...**→**SIS Data Logger**.

The program will send a command to the relevant PU for starting and stopping logging. When logging is active the PU will transmit the data from the sensor input out on a port received by the external program. The external program will be responsible for decoding, displaying and logging the data.

In contrast to alternative 2, *PU sensor input logging* on page 440, you may now get a running update of the received data in the display as the data is being logged.

The following input parameters and controls are available:

- **Select Echo Sounder:** This drop down list will contain currently started echo sounder(s) only. (It is only possible to log on echo sounders that have been started by SIS).
- **PU Sensor Port:** The PU sensor input port to log from. The possible port selections are normally the same as listed in the top row in **PU sensor status**→**PU sensor input status** frame.

- **Use default storage:** When selected (ticked) a predefined set of storage options are used:

- The default directory is:
`...sisdata/common/maintenance`

- The default file name is:
`PU_yyyymmdd_hhmmss.log`
where the date and time is the UTC time when logging is started.

When the operator un-ticks this selection a pop-up is displayed allowing the user to select an alternative storage location and a file name. Note that if the file already exists the new logged information will be appended to the existing file.

- **Log File:** This element contains currently selected storage folder and is used for display only.
- **Log button:** The logging operation is turned on and off using the log button whereby all necessary logging information is sent to currently selected PU.

When logging is active all user selections are inactive (i.e. gray coloured). To change the PU sensor port setting and the storage settings logging must be off.

- **Options**→**Show Datagram Prefix** is used to turn the info line printed at the head of each datagram packet on or off.

The info line contains packet size and a time tag.

PU sensor input logging

This alternative is a low level solution based on internal SIS functionality for decoding and storing received data. No visual update of the decoded stored data is provided. This is in contrast to alternative 1 in *SIS Data Logger for PU sockets* on page 439 where a separate program is used giving a running update when logging.

The operator interface for controlling this alternative is located in the **PU sensor status** →**PU sensor input logging** frame:

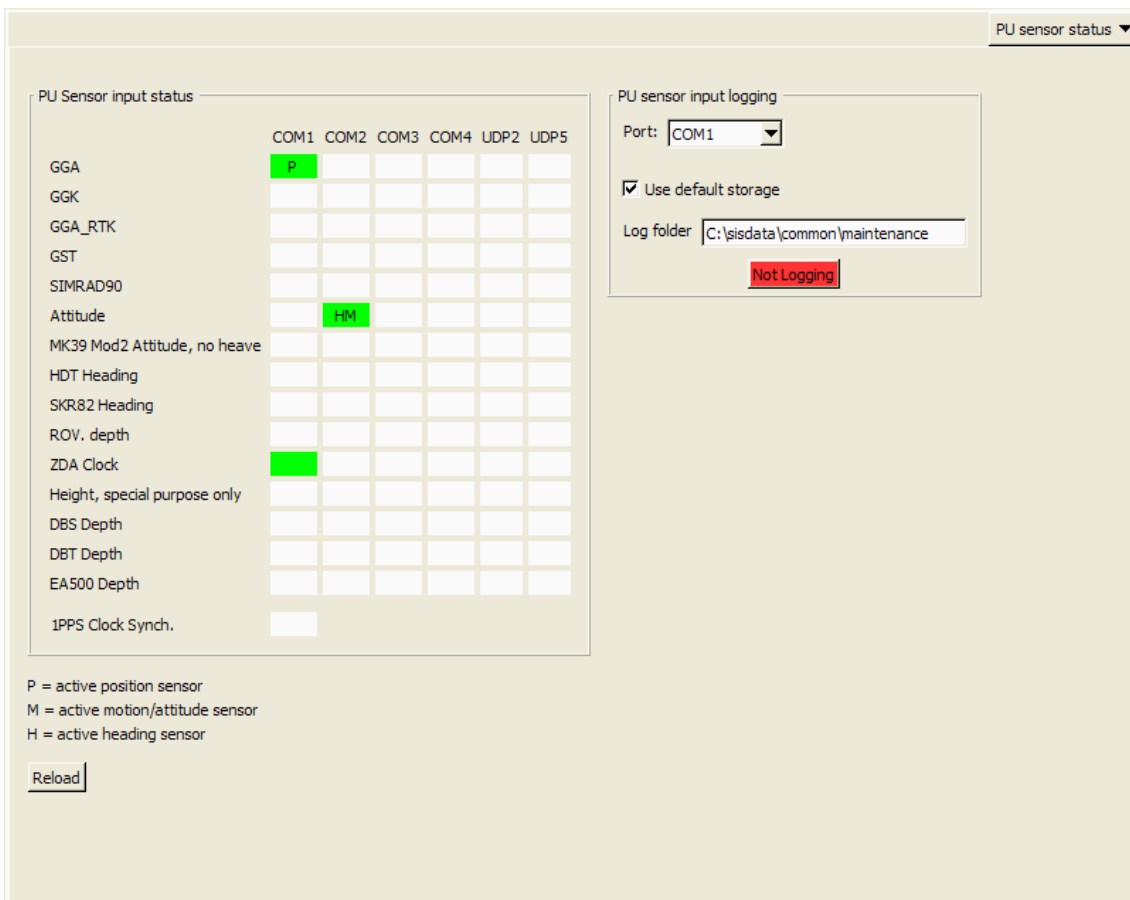

The **PU sensor input logging** interface is enabled and displayed using the following key combination for the above listed type of echo sounders:

Shift+Ctrl+Alt+RightMouseButtonRelease:

The following input parameters and controls are available:

- **Port:** The PU sensor input port to log from. The possible port selections are normally the same as listed in the top row in **PU sensor input status** interface.
- **Use default storage:**

When selected (ticked) a predefined set of storage options are used:

- The default directory is:
...sisdata/common/maintenance
- The default file name is:
PU_Input_YYYYMMDD_hhmmss.log
where the date and time is the UTC time when logging is started.

When the operator un-ticks this selection a pop-up is displayed allowing the user to select an alternative storage location and a file name. Note that if the file already exists the new logged information will be appended to the existing file.

- **Log folder:** This element contains currently selected storage folder and is used for display only.

- **Log button:** The logging operation is turned on and off using the log button whereby all necessary logging information is sent to the currently active PU. The button colour and text reflects current logging status:

- Red: Not logging

- Green: Logging

When logging is active the **Port** selection and **Use default storage** tick button is inactive (i.e. gray coloured). To change the PU sensor port setting and the storage settings logging must be off.

Note

The maximum log file storage size is 2Gb. If this limit is reached logging to file stops.

C-MAP CM-93/3

Note

C-Map features are visible in SIS only if C-Map is installed.

Related topics

- *C-MAP detail level* on page 41
- *C-MAP – Licence administration* on page 379
- *Geographical – C-MAP manipulation mode* on page 225

What it does

The C-MAP CM-93/3 Professional is a global chart database intended for use on advanced electronic charting and navigation systems.

CM-93/3 supports all the new object classes and attributes defined by S-57 Ed. 3.0, as well as the S-57 data model and updating mechanism.

Note

The information in this chapter originates from C-MAP technical documentation.

Specification of minimum performance

The C-MAP CM-93/3 Software Development Kits (version 3.0) have been designed to allow manufacturers to implement the various C-MAP CM-93/3 chart databases into their navigation and land based systems. In order to ensure that the CM-93/3 cartography is used and displayed correctly within manufacturers systems, the Specification of Minimum Performance document to which we will run a system audit on completion of the software development.

C-MAP S-57 Verifier and CM-93/3 Compiler

Installation



The S-57 verifier and CM-93/3 compiler (hereafter called the compiler) is installed together with the software distributed by the manufacturer. When this software is installed you should ensure that the eToken (part number: CM-eToken-S57) is inserted into one of the available USB sockets. This eToken is used to unlock the compiler and to license CM-93/3 charts. Once the software is installed clicking on the icon will start the compiler.

The compiler main screen looks approximately as follows:

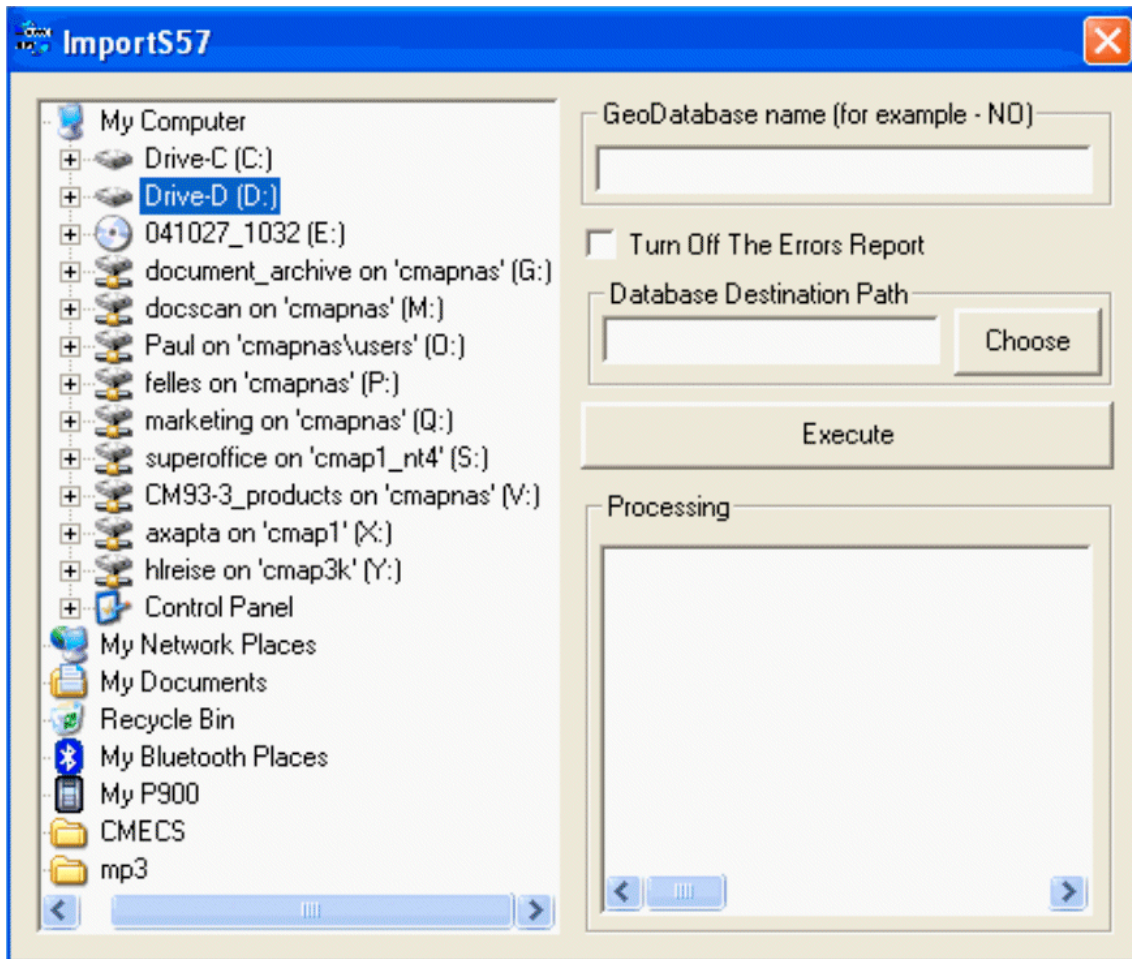

Using the compiler

Browse to the location of the stored S-57/3 charts in the left hand window (normally in an ENC_ROOT directory), and enter the issuing Hydrographic Office at the top of the right hand window. The issuing Hydrographic Office code is always the same as the first two letters of the file name. For example a Norwegian ENC may read something like “NO2B0412.000” and therefore the issuing HO code is “NO”.

Enter the destination path for the compiled database. This should be an existing directory on the hard disk (for example C:\ENC).

Click on Execute to compile the S-57/3 charts to CM-93/3. If the S-57/3 is fully compliant with the IHO specification, the charts will be compiled into a local CM-93/3 database and automatically registered in the database administrator. They can then be viewed on the screen by either setting the ENC database as default or by opening the application and go to the Add Database option to add the recently imported S-57/3 into the current view.

During the verification phase it may become evident that the S-57 files being imported are not fully compliant with the S-57/3.1 specification. If this is the case then one or more warnings or errors will be displayed and the user will be given the choice to CONTINUE (in which case the compiler will continue verification but not compiler the

database), to SKIP (the database will be compiled but may contain serious errors) or to CANCEL. In general warning messages will not stop the compilation process but errors may cause the database to be incorrect or even the system displaying them to crash.

The C-MAP Cartographic Service

Overview

The system that you are now using has the capability of using and displaying the latest C-MAP CM-93/3 worldwide vector chart database. These charts are fully compliant with the latest IHO S-57 3.1 specifications and, when using the CM-93/3 ENC database in an approved ECDIS, are considered equivalent to the navigational charts required by the SOLAS (Safety Of Life At Sea) convention.

In order to prepare the system for use with the C-MAP CM-93/3 database, there are a number of things that will first need to be carried out: -

Registration of the system at C-MAP Norway

When a system is installed that has the capability to use the CM-93/3 database, it is required that an Aladdin eToken supplied by C-MAP is connected to the system (if the system has and supports USB). The eToken provides the system with a unique System ID that enables C-MAP to issue correct licenses. The actual System ID can be found on the eToken itself, on the back of the installation CD box or on a sticker placed on the equipment. This ID must be quoted on all chart orders, either by email (license@c-map.no) or by fax +47 51 46 47 01.

When a system does not have a USB port or does not have support for the eToken, a file called USER.USR will be automatically created during initial installation (normally in the Program Files\CM93v3 SDK directory). This file contains the Company ID and System ID assigned to the ECDIS/ECS system when it is installed. These ID's can be found on the back of the installation CD box or on a sticker placed on the equipment. This file must always be sent to C-MAP Norway by email (license@c-map.no) when installing the software. Licenses can only be generated once this file has been received and registered by C-MAP. It is important to note that the software may need to be reinstalled and reinitialised if the operating system or hardware is upgraded (see the troubleshooting section).

Please note that in some cases the manufacturer of the system will have already pre-registered the system by sending the USER.USR file to C-MAP.

If during installation you do not know your Company ID or System ID, please contact C-MAP Norway before continuing installation of the software.

Ordering charts

A chart order may be sent together with the registration of the system as described above. It is essential that the required information is sent to C-MAP when ordering charts for a system. C-MAP has issued order forms specifying the information that is required, and contains vital information that will allow us to monitor and maintain your licenses

throughout the lifetime of the system. Charts can be ordered by Zone, Area or Cell and these can be seen on Internet pages at www.c-map.no or by downloading the Chart Product Catalogue also available on the web site. Price quotations can be obtained via your chart dealer or direct from your local C-MAP office. Once the license order has been prepared it should be emailed to license@c-map.no or faxed to C-MAP Norway AS (+47 51 46 47 01).

Applying licenses

Once the order has been received at C-MAP, a license will be generated and transmitted back to the user. This may be in the form of a single alphanumerical string (16 characters), or in the form of a file called PASSWORD.USR. Once this license has been received it should be input using the License Administrator software designed and supplied by the ECDIS/ECS manufacturer. There are two types of licenses, purchase and subscription. Purchase licenses are valid indefinitely while subscription licenses need to be renewed each 12 months from the start of the subscription. Failure to renew a subscription will result in the charts becoming unavailable.

Troubleshooting

If you are having problems installing your software or charts please check the following before calling C-MAP: -

- You are installing on Windows NT, Windows 2000 or Windows 98 second edition. The system will not normally run under Windows 95 or Windows 98 first edition.
- That you have registered the WORLD database in the GDBADMIN application.
- That the registered WORLD database is available. If you are running the database from the CD drive, the CD-ROM must be loaded.
- That you have correctly typed the license string.
- That you have not reinstalled Windows or any major hardware components. If you have done this you will probably need to reinstall your software (only required for systems that are not using eToken).

Contact Information

For information or help please call your nearest C-MAP Office (details can be found on the reverse side of the C-MAP chart CD box) or contact C-MAP Norway: -

C-MAP Norway AS Post Box 212 Hovlandsveien 524379 Egersund Norway Tel: +47 51464700 Fax: +47 51464701 technical@c-map.no

Global event marker

The Global Event Marker system consists of two programs:

- One server that runs on an Operator Station (for example the HWS) connected to a multibeam echo sounder (EM) Processing Unit (PU)
- One or more clients on Windows PCs in the network

The Global Event Marker Handler (GEMH) needs two inputs; position datagrams from an EM PU, and events from Global Event Marker clients on the network.

Note that the position datagrams needed by GEMH must be subscribed to using the **Request datagrams from an echosounder** utility found in **Tools**→**Custom**→**Datagram distributions**. See *Request datagrams from an echo sounder* on page 559

Use the IP address of the GEMH HWS and a free port address. This port address must be used in the GEMH options setting (see below).

The PU will send position datagrams to GEMH even when the EM is not pinging.

GEMH will send events to other SIS installations on the network, including Helmsman Displays. The IP addresses of these installations must be set in GEMH.

GEMH will also send CS datagrams to single beam echo sounders (EA). CS datagrams are sent as broadcasts on the network, so only the UDP port must be set in GEMH.

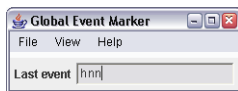

All events are logged to a file, normally **events.ksgpl**. In the File menu you can open any file. When the file is opened, all events in that file is sent to all SIS installations.

You can also at any time resend all events to all SIS installations from the View menu.

The last event is displayed in the textfield together with the IP address of the sender.

Options in GEMH are found in the File menu. The first lines set the UDP port where events arrive. This port number must be the same as the port number in the file Events.ini used by the Global Event Marker clients (see below).

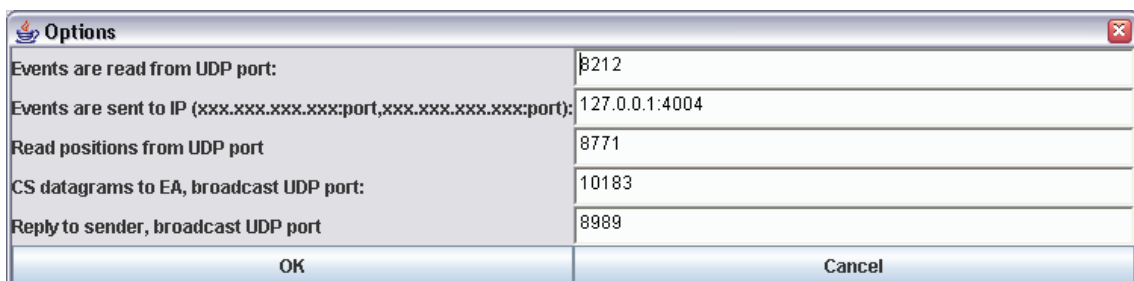

Events are sent to a list of SIS programs. The format of this list is
xxx.xxx.xxx.xxx:nn,xxx.xxx.xxx.xxx:nn,...

xxx.xxx.xxx.xxx is the IP address and nn is the UDP port number, normally 4012. Remember to use a comma (,) to separate the addresses.

Positions are read from a UDP port. The port is the same as set when the position datagram subscription is defined (see above.)

EAs listen for CS datagrams on a port, normally 10183.

The last event is also sent as broadcast to all Global Event Marker Clients (GEM). All of them will then display the time the event arrived and the associated text.



The GEM can be installed on any Windows PC in the network. Simply copy the files Events.exe and Events.ini to a directory and run Events.exe from that directory. The file Events.ini can be used to set the parameters and texts for this window. Note that the IP address in Events.ini is the IP address of the PC running GEMH.

You can then send an event to GEMH simply by pressing the button. A text is optional and can be sent together with the event.

The last event on the network is displayed in the textfield below, together with the IP address of the sender and the time the event occurred.

PU simulator and playback

The PU Simulator is a replay program using logged raw data from EM multibeam echo sounders. The program is launched from the menu **Tools**→**Custom**→**PU Simulator**.

The PU Simulator is launched in the background and then waits for command signals.

When the PU Simulator is launched, a directory selection box is opened where you select the directory where the **.all** data files are located. This directory is written in the textfield **Raw Data Path**.

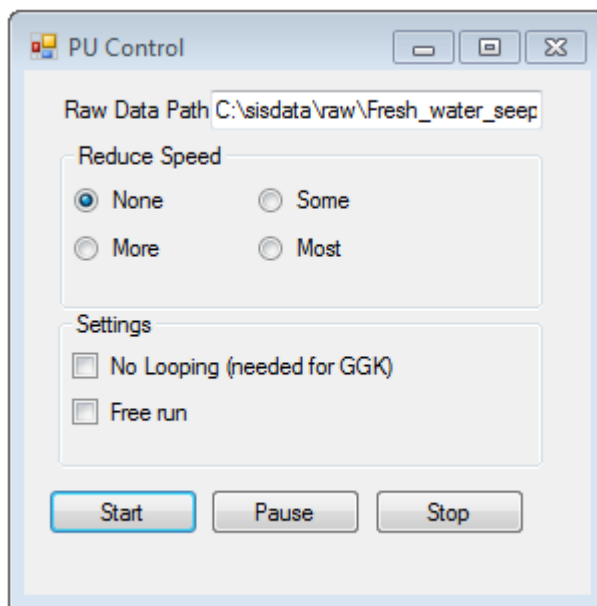

The **PU Control** holds the following parameters:

- **Raw Data Path** is the path to where the **.all** files are located.
- **Reduce speed**: Choose between **None**, **Some**, **More** and **Most** to set the update rate of the play-back from as natural speed to slower speed in order to be able to better identify data details. By default set to **None**.
- Press **Start** to start the simulation.
- Press **Pause** to pause the output of datagrams from the selected raw data file.
- Press **Stop** to terminate the PU Simulator.
- **No looping**: this is required for replay of data with GGK positions. The date and time in the original datagram are then not replaced by current time during replay.
- **Free run**: to set the update rate of the play-back as fast as possible (depending on your PC).

The PU simulator will read all the **.all** files in the directory over and over again, and send out the datagrams as if they were sent from an EM echo sounder. However, there are some differences:

- The time in the header of all datagrams will be set to the current time in UTC. Also the time in the GGA text string in the position datagrams will be set to this time.

- The simulator will not broadcast datagrams to SIS before it has received the information about which directory to read from. Therefore SIS must be started after pressing **Start** in the simulator.
- Other data in the datagrams will not change. This means that the Numerical display in SIS will display the original time information from the datagrams.
- The PU Sensor status frame will not contain any information during play-back.
- The Installation parameters frame and the Runtime Parameters frame have no effect if the user tries to change any parameters.

Related operational procedures

- *How to run the PU simulator* on page 203

Create grid from ASCII files

This tool can be used to create terrain models in SIS from ASCII files.

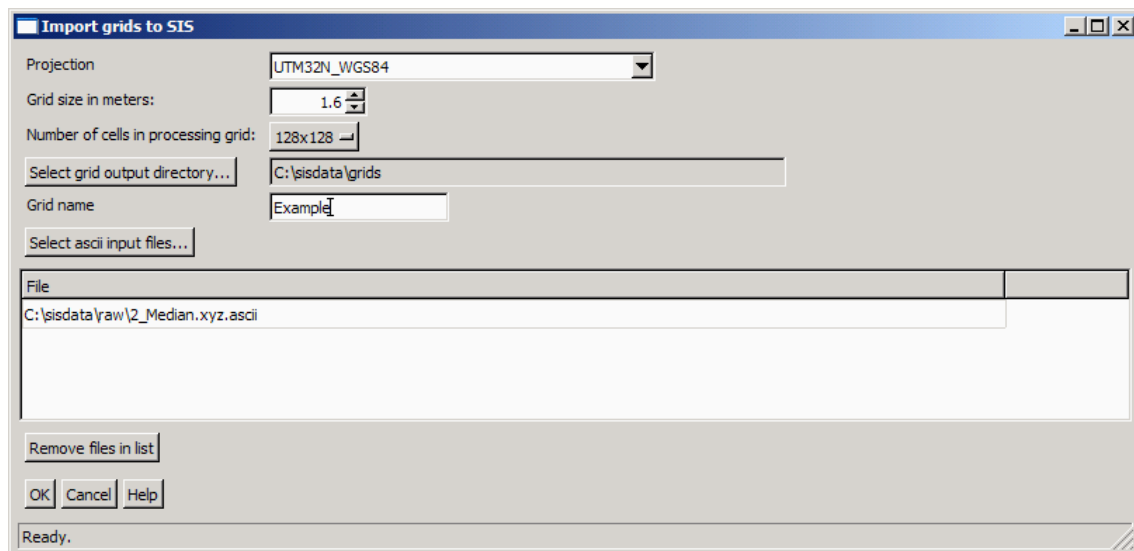

The format of the ASCII file is as the following example.

```

*** Neptune Ascii file from Kongsberg Simrad A/S ***
Survey name: EM710_Blucher_2005_02_23
Processing operator name: tp
Datum: WGS84
Half axis: 6378137.0000000
Flattening: 1/298.25722356300
Coordinate system: Lat/Long
Latitude min.: 59.66354720
Longitude min.: 10.59076500
Latitude max.: 59.70350375
Longitude max.: 10.62006250
Latitude cell size: 5.00 meter
Longitude cell size: 5.00 meter
Median depth of each cell

10.6148669 59.6635847 40.14
10.6149773 59.6635844 45.31
10.6150679 59.6635841 50.54

```

The first lines defines the header. The first empty line ends the header, and the header must always be present. This means that the data in latitude, longitude, depth must follow after an empty line. Latitude and longitude are in decimal degrees and the depth is in meters.

The file format can be created by Neptune (BinStat) to output geographic coordinates in ASCII format. Normally the median value for the grid cell is written in this format, which makes it faster to generate the grid in SIS. If the grid cell size in BinStat is e.g. 2 meters, 400 cm can be used as the grid cell size in SIS.

1 Select **Tools**→**Custom...**→**Create grids from ascii files**

- 2 Select the **projection** of your current SIS survey, i.e. the projection you want the imported Neptune grid to appear in. The datum is given by the header of the Neptune file.
- 3 Set **Grid size in meters** and **Number of cells in processing grid** according to depth and coverage of your data.
- 4 Press **Select grid output directory...** to specify where to store the grid. Note that this directory must exist and be accessible for writing.
- 5 Type a descriptive **Grid name**.
- 6 **Select ascii input files** opens a file selection dialog where you can browse for the Neptune files to import.
- 7 Select **Remove files in list** if you want to remove a selected file from the list.
- 8 Press **OK** to start the process.
- 9 Select **File→Import/Export...** from the SIS main menu.
- 10 Press the **Import** button.
- 11 Browse for the directory where you selected to store the grid and select the directory having the grid name that you entered.
- 12 Press **OK** to return to the **Import/Export** dialog box.
- 13 Highlight the survey to import and press **OK**.
- 14 In the **Geographical** view, press **Zoom to world** to display the grid.

Note _____

The GridEngine must be running for this program to work.

Note _____

If the process causes GridEngine to stop you may have to kill the Import from the process manager and restart the GridEngine.

KSGPL

The **Kongsberg SIS Graphical Programming Language (KSGPL)** is a powerful extension to SIS allowing the user to display geographical information in the Geographical window.

Related topics

- *Geographical – Display options* on page 211
- *Geographical – KSGPL edit mode* on page 223
- *Geographical – Load background data* on page 224

Overview

The KSGPL protocol defines a set of ASCII datagrams that are sent between a user programmed application and the Geographical window in SIS. The user application opens a network connection (UDP) to the Geographical window and writes ASCII text string to this connection. These KSGPL strings can be used to send lines, points and pictures to the Geographical window, and to define the position of an earlier defined object such as a ship. These objects will then be drawn in the Geographical window. A lot of attributes can be set by the operator and the user application to control these objects, both at the time they are sent to the Geographical window and afterwards.

You may edit objects sent to the Geographical window. You can split, join, add, delete and move lines, as well as add, delete and move points. The user's actions are sent back to the user application, which then can decide what to do next.

The user application is responsible for storing the data. This allows the programmer to decide where the data is stored, in a file or in any database system already in use. The user application can also decide to add its own user interface so that more information can be added to the objects added by the operator. KSGPL is used to add background data to the Geographical window. This background data can not be edited.

KSGPL language reference

The following datagrams are sent from the outside to the Geographical window.

```
OBJECT <id>
  POSITIONTYPE <GEO| SCREEN | RELATIVE>
  [TYPE <number>]
  [INFO <text>]
  [LINE [ [WIDTH <number>] [SOLID|DOTTED] [COLOR <number>]
    [TRANS <0-100>] ] <POS2D|POS3D> <positions>]
  [POLYGON [ [BORDERWIDTH <number>] [SOLIDBORDER|DOTTEDBORDER]
    [BORDERCOLOR <number>] [BODYCOLOR <number>]
    [SHOWBORDER|NOSHOWBORDER] [SHOWBODY|NOSHOWBODY]
    [trans <0-100>] ] <POS2D|POS3D> <positions>]
  [POINT [ [SIZE <size>] [COLOR <number>] [TRANS <0-100>] ]
    <POS2D|POS3D> <position>]
  [TEXT <text> [ [SIZE <number>] [COLOR <number>]
    [ORIENTATION <0.0-360-0>] [TRANS <0-100>] ] <POS2D|POS3D>
    <position>][IMAGE <file> [ [GRAVITYPOINT<0-100> <0-100>]]
    <POS2D|POS3D> <position>]
```

```
OBJECT END
OBJECT <id> DELETE OBJECT_END
```

The two tables below show the internal datagram descriptions

Datagram	Description	Required
POSITIONTYPE <GEO>	Use geographical coordinates	Yes, either GEO, Screen or RELATIVE
POSITIONTYPE <SCREEN>	Centimeters on the screen (float) relative to the lower left corner of the Geographical window. This object will always stay in its position on the screen	
POSITIONTYPE <RELATIVE>	Meters relative to origo (0.0m, 0.0m) in the world	
INFO <text>	Name or description of this object	No
TYPE <number>	The id of the type this object belongs to	No
LINE [[WIDTH <number>]]	Width of the line in pixels	No. Default is 1.
LINE [[SOLID DOTTED]]	Solid or dotted line	No. Default is SOLID.
LINE [[COLOR <number>]]	Colour of the line	No. Default is black.
POLYGON [[BORDERWIDTH <number>]]	Width of the border in pixels	No. Default is 1.
POLYGON [[SOLIDBORDER DOTTEDBORDER]]	Solid or dotted border	No. Default is SOLIDBORDER.
POLYGON [[BORDERCOLOR <number>]]	Colour of the border	No. Default is black.
POLYGON [[BODYCOLOR <number>]]	Colour of the polygon border	No. Default is red.
POLYGON [[SHOWBORDER NOSHOWBORDER]]	Show the border or not	No. Default is SHOWBORDER
POLYGON [[SHOWBODY NOSHOWBODY]]	Show the body of the polygon or not	No. Default is NOSHOWBODY.
POINT [[SIZE <number>]]	Size of the point in pixels	No. Default is 1.
POINT [[COLOR <number>]]	Colour of the point	No. Default is red.
TEXT [[SIZE <number>]]*	Font size	No. Default is 9.
TEXT [[COLOR <number>]]	Colour of the text	No. Default is red.
TEXT [[ORIENTATION<0.0—360.0>]] *	Orientation of the screen aligned text in degrees. Positive value is counter clockwise	No. Default is horizontally aligned
IMAGE [[GRAVITYPOINT <0–100> <0–100>]] *	Gravity point of the picture in percent (i.e. where on the picture the coordinate is given). Horizontal and vertical values	No. Default is lower left corner.

Datagram common for all objects	Description	Required
OBJECT <id>	A unique identifier. The old object will be deleted if the corresponding identifier already exists in the system.	Yes.
<TYPE> <id>	What kind of type this object is.	No
<POS2D POS3D> <position>	Position(s) of the object. POS2D = (x,y) POS3D = (x,y,z)	Yes
[[TRANS <0-100>]]	Transparency of the object.	No, Default is 0. (No transparency at all.) The polygon border will not be affected by the transparency setting. Note _____ <i>Transparency is disabled for images.</i>
OBJECT_END	Datagram end.	Yes

Note _____

* — *Not yet supported.*

If the object sent into the system is missing required fields, the object is disregarded. No output is given.

An object has always an identifier that must be unique within the application. If an object with the same id exists in the Geographical window, that object is deleted (no message given as output) and the new object is put in. The object may consist of one or more instances of lines, polygons, points, texts and images.

A position has either two or three floating-point numbers and is enclosed in parentheses like: (1.1 2.2 3.3). Comma and semi-colon may be used to separate the tokens, i.e.: (1.1;2.2;3.3;t) to make the file more readable.

An object may be of a type. Object without types will be entered into the system in a default container. An object of a nonexistent type (if given) will be ignored.

Objects may be deleted from the Geographical window by the DELETE datagram. The corresponding id will be deleted.

KSGPL output from the Geographical window

The Geographical window will have line and point editing capabilities on objects that consists of one line only or one point only. Composite objects consisting of several lines and/or points cannot be edited. When the user has edited data that have been put in via KSGPL, the Geographical window will output these KSGPL datagrams:

```

ACK <status> ACK_END
OBJECT <id>
MARKED OBJECT_END
OBJECT <id> MARKED OBJECT_END
OBJECT <id> DELETED OBJECT_END
OBJECT <id> CREATED OTYPE <type_id> POINT <POS2DT|POS3DT> <position>
OBJECT_END
OBJECT <id> CREATED OTYPE <type_id> LINE <POS2DT|POS3DT><positions>
OBJECT_END
OBJECT <id> EDITED POINT <POS2DT|POS3DT> <position> OBJECT_END
OBJECT <id> EDITED LINE <POS2DT|POS3DT> <positions> OBJECT_END
OBJECT <id> JOINED_LINES <second_line_id> <POS2D|POS3D>
<positions> <POS2D|POS3D> <positions> OBJECT_END
OBJECT <id> SPLIT_LINES <POS2D|POS3D> <positions>
<POS2D|POS3D> <positions> OBJECT_END
    
```

The table below shows the external datagram descriptions:

Datagram	Description
ACK <status> ACK_END	An acknowledge message sent whenever a datagram has been received by the Internal KSGPL Handler. 'status' is an integer informing about status of the datagram just received. - 1 = Datagram failed to be recognized 0 = Reserved 1 = Datagram successfully recognized
OBJECT <id>	A unique identifier. This will be 0 for new (CREATED) objects
POS2D <position(s)> POS3D <position(s)> POS2DT <position(s)> POS3DT <position(s)>	Position(s) of the object: POS2D = (x,y) POS3D = (x,y,z) POS2DT = (x,y,t) POS3DT = (x,y,z,t)
MARKED	The object has been marked by the user. No changes are done to the graphics. The External KSGPL Handler can now take proper customized action(s).
DELETED	The object has been deleted by the user and removed from the scene.
CREATED OTYPE <type_id> <POINT LINE>	The user has created a new point or line of a given type. The object has been removed from the scene.
EDITED POINT LINE	The user has edited the given point or line. The object has been removed from the scene.
JOINED_LINES <second_line_id> <POS2D POS3D> <positions_of_line_one> <POS2D POS3D> <positions_of_line_two>	The user has joined two lines into one. The preceding OBJECT <id> is the ID of the first line. <second_line> is the ID of the second line. The lines are connected together between the last vertex in the first line and the first vertex in the second line.

SPLIT_LINE <POS2D POS3D> <positions_of_line_one> <POS2D POS3D> <positions_of_line_two>	The user has split an existing line into two line segments. The preceding OBJECT <id> is the ID of the original line before being split. Note <i>The user has removed one vertex in the original line (and not only deleted a sub line segment).</i>
OBJECT_END	Datagram end.

A position has either two or three floating-point numbers and a time field enclosed in parentheses like: (1.1 2.2 3.3). POS2DT or POS3DT positions also have a time field 't' which is given in the format: yyyyMMddhhmmSS.sss (year, month, day, hour, minute, seconds and decimal seconds.) POS2DT or POS3DT are only used when the user has EDITED or CREATED something in the scene. If the user has EDITED e.g. an existing POS2D line by moving one of the vertices, the unmoved vertices will have the time field set to '0000000000000.000' when sent out. POS3D(T) are only sent if the original object was inserted into the system using POS3D coordinates. Respectively the same with POS2D(T).

Objects are assumed to be sent to an external program and deleted from the Geographical window as soon as they are CREATED or EDITED and then sent back to the Geographical window. After that, line objects may be split (SPLIT_LINES) or joined (JOINED_LINES). These operations are then only allowed on lines that have been put into the Geographical window from an external source

Selected objects remain in the Geographical window, but CREATED, EDITED, JOINED_LINES and SPLIT_LINE are deleted from the Geographical window when these datagrams have been written to socket. It is assumed that the receiving program will handle the necessary storage of the changed items and then send them back to the Geographical window to be redrawn in a new state. This will assure the user that the data have been successfully stored.

For an edited line or point the position(s) are the new, changed position(s). A line may also get new vertices inserted into the line (both at the ends of the line and between vertices in the line) and have vertices deleted. The output will be written when the user has completed the editing of the line, not while he is editing.

New objects will have id=0. For a split line the id will be the id of the original line.

Input of S-57 formatted chart files

Note

This procedure may be very slow if very accurate models are to be made for large areas. However, remember to keep the ascii file that is created, as this can be reused later in case a new terrain model is to be created. Then simply create a new terrain model from this ascii file.

You may use some of the data in an S-57 chart file as background data in SIS directly. Coastlines and dryfall (a depthcontour with depth 0.0 meters) are extracted into KSGPL formatted files which can be displayed in SIS. The depth contours are also used to construct a 3D terrain model.

How to convert S-57 chart files to SIS input data

- 1 Select **Tools** → **Custom** → **S-57 converter** and a new window opens up:

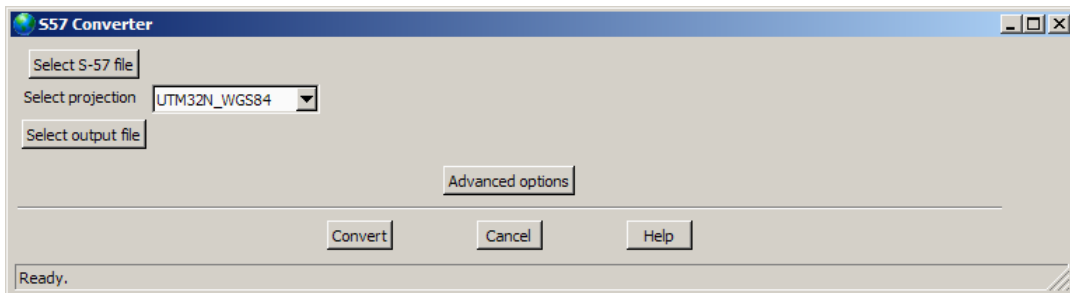

- 2 Press **Select S-57 file** and select the S-57 file in the file selection dialog window.
- 3 Choose the map projection from the pulldown menu. The projections listed are the projections registered in SIS.
- 4 Press **Select output file** and choose the output file name.
- 5 You may want to press **Advanced options** if you are not happy with the results from the first run:

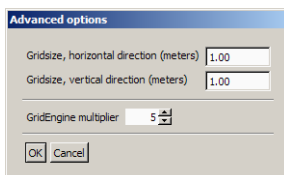

Here you can set the parameters defining how the to construct the terrain model. **GridEngine multiplier** is a factor used to define the grid cell size in the GridEngine. It should normally be set to 2 or higher.

- 6 Press **Convert** and wait.

Note

Note that this procedure may take several hours depending on the parameters.

The output is two files, one **.ksgpl** and one **.s57**. To use this data in SIS, follow the procedure below.

How to use the output from S57ToSIS

- 1** Open **File** → **Import/Export** and select **KSGPL** as the data type.
- 2** Open the **.ksgpl** file generated above and press **OK**.
- 3** Open **Tools** → **Custom** → **Create grid from ASCII files**.
- 4** Select the **.s57** file as input and create a terrain model.
- 5** Open **File** → **Import/Export** and select **Surveys** as the data type.
- 6** Select the terrain model created above.

The first procedure must be run only once. The output is one **.ksgpl** file and one **ascii** file. These files do not need to be regenerated unless the **S-57** file is changed. This means that this procedure can be run in the office and the output can be sent anywhere. Also the generation of grid from **ascii** files needs to be done only once. When the terrain model is created, it can be reused. This can also be done in the office, and then simply send the complete terrain model to other users.

Note

The projection is locked once the terrain model is created so everyone who uses this terrain model, must have the same projection defined.

How to use SIS on an AUV/ROV

This section explains how to use SIS on an Autonomous Underwater Vehicle (AUV) or on a Remotely Operated Vehicle (ROV), where an EM 2000/EM 3000 echo sounder is installed.

The EM 2000/EM 3000 on board an AUV is controlled via Ethernet communication as indicated in figure below. When SIS starts up, it will search for all echo sounders on the network, and the EM 2000 or EM 3000 will broadcast its existence, detected by the SIS.

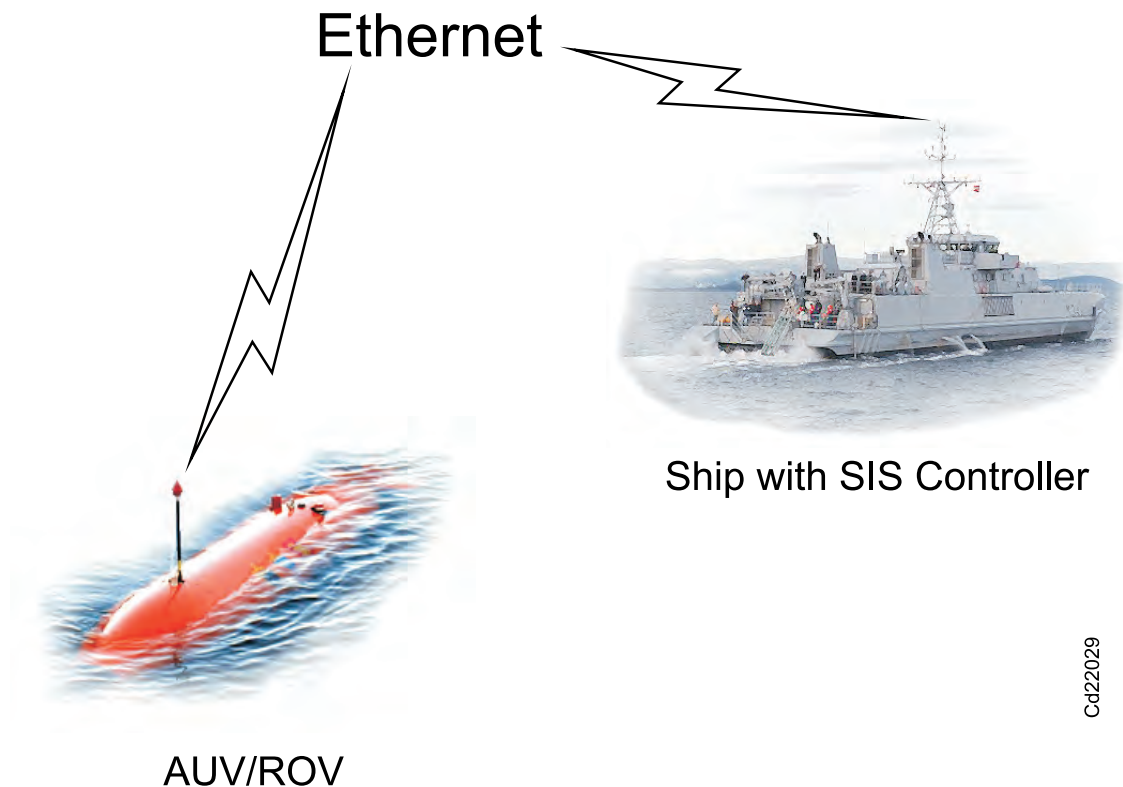

Cd22029

How to set up the EM 2000/EM 3000 on the AUV from SIS

- 1 Attach the internal disk in the EM 2000 / EM 3000.
- 2 Open SIS
- 3 Open the **Installation Parameters**
- 4 Enable PU logging to local disk as described in *How to enable PU logging to local disk* on page 461
- 5 Set PU parameters as described in *Default or current settings at PU startup* on page 462
- 6 In Installation Parameters there are four UDP port numbers, labelled UDP 1-4. When using EM 2000/EM 3000 logging to internal disk, UDP4 is renamed to PU Logging. Note the UDP port number in use by UDP2; this is the port number where the third party software shall listen for data.
- 7 Shut down SIS
- 8 Restart the EM 2000/EM 3000

When the EM 2000/EM 3000 is powered on again, it will start with the installation parameters set. Datagrams will be sent to the UDP ports as defined, and any software can be used to read these datagrams.

9 Send datagram P10 to port 2012 to the PU To turn logging on

10 Send P02 to stop logging.

In the figure below it is shown how the EM 2000 is set up after above procedure has been carried out. P10 and P02 control datagrams are used to start and stop the logging to disk.

Figure 27 How the EM 2000 on and AUV/ROV is set up

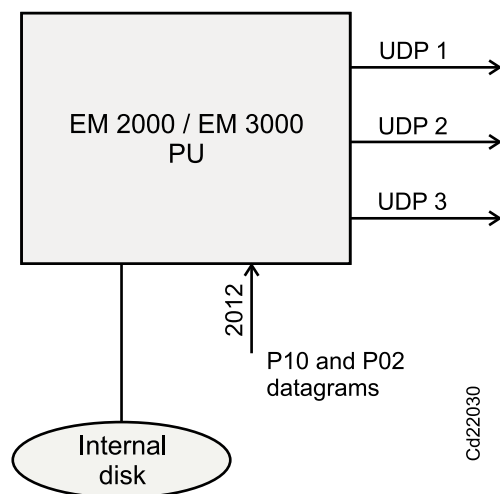

How to enable PU logging to local disk

Note

This feature is only available for EM 2000 and EM 3000.

- 1 The SIS user can turn logging on and off by using a simple tick button in the **Installation parameters**→**Output Setup** frame. When this tick button is set, the **Host UDP4** port entry in the **UDP Host Port** combo box is substituted with a **PU Logging** port. By selecting the **PU Logging** port it is possible to select which datagrams to log to the PU hard disk. Initially a default datagram selection is presented, but it is modifiable as indicated.
- 2 When PU logging is set the port number displayed is 2999. This is just a dummy number signifying that the PU is logging to disk.
- 3 The selected PU logging setup is activated (i.e. PU logging turned on or off) when the **OK** button is pressed.

Note

When the PU is logging to disk it will not send ANY datagrams out on the Host UDP4 port.

*When the PU logging feature is turned off (i.e. tick button deselected) the normally configured settings for Host UDP4 will be used again. Remember to press the **OK** button to activate the new setting.*

Default or current settings at PU startup

Note

This feature is only available for EM 2000 and EM 3000.

When the PU is turned on, this feature will enable the PU to use a standard (factory) parameter setup or a setup previously configured and installed in the PU by SIS.

In the latter case the PU may subsequently be started independently, without SIS connected. This capability will allow an AUV/ROV operator to use SIS to initialize the PU with a specific setup before disconnecting SIS and launching the AUV/ROV into the water.

You can control this feature by a radio buttons found in the Installation parameters, ROV Specific frame: **Installation Parametes**→**Sensor Setup**→**ROV Specific**. The radio buttons are labelled **Use default settings at PU startup** and **Use current settings at PU startup** respectively.

The procedure for setting the PU to use the current parameter setting is as follows:

- 1 The PU must have been started by SIS
- 2 Configure the required installation and runtime parameters as required using the normal configuration procedure

Note

*Make sure to press the **OK** button in the **Installation Parameters** frame.*

- 3 In the Installation parameters, ROV Specific frame press the **Use current settings at PU startup** radio button.

The PU is now configured and the current setting stored for use when the PU is turned on again.

How to set the PU to use default parameters

The procedure for setting the PU to use the default (factory) parameter setting is as follows:

- 1 The PU must have been started by SIS
- 2 In the **Installation parameters**→**ROV Specific** frame press the **Use default settings at PU startup** radio button

The PU will now use the default (factory) settings when it is turned on the next time and it will normally require that SIS is connected to initialize and control it.

Note _____

*When the radio buttons are pressed a signal is sent directly to the PU without the need to press the OK button (as for normal installation parameters). Therefore, when the **Use current settings at PU startup** radio button is pressed the required setup must already be present in the PU using the procedure above.*

Note _____

*Note that after the **Use current settings at PU startup** radio button has been pressed, the PU parameter setup at that time is remembered and used during next startup. If further installations and runtime configurations are performed, without pressing the radio buttons, the changed configuration will be used until the PU is turned off and on again.*

Fetch and delete data from the internal harddisk

FTP can be used to fetch and delete data from the internal hard disk, or replace the disk with another and insert it in another PC to read the data.

CUBE

The CUBE (Combined Uncertainty and Bathymetry Estimator) algorithm is developed at The Centre for Coastal and Ocean Mapping (C-COM)/Joint Hydrographic Centre (JHC) at University of New Hampshire. The algorithm is available as a library and is used inside a separate module in SIS. The CUBE algorithm can be used as an alternative data gridding and data cleaning method in SIS. The gridding and data cleaning is a default process done by the GridEngine.

Related topics

- *Create CUBE grid* on page 369

About the implementation of CUBE in SIS

CUBE is not available when logging data. CUBE grids are created by importing raw data files in the Kongsberg Maritime .all-format. Already gridded surveys can be reimported at a later time.

The CUBE module in SIS receives ping data on UDP where depth and angle gate are applied to the data. The horizontal and vertical error estimate for each beam is calculated using the Kongsberg Maritime error model and not the error models included in CUBE. The default processing parameters for the CUBE algorithm are used.

The GridEngine holds both a processing grid and a display grid. The display grid is split up in six levels of details, LODs, to speed up the display in the geographical view when features as automatic update or ship in centre are turned on. In CUBE it is the processing grid that is displayed and an automatic update or ship in centre can give slow response when updating the geographical view.

The implementation of LOD in the GridEngine also results in less sensitivity to the grid cell size when displaying grids - see the next four figures. With a small grid cell size a lot of nodes get no depth value assigned.

SIS must chose between either GridEngine or CUBE grids. This selection is done from the **Tools**→**Custom**→**Set paramenters**→**Logging** menu.

Figure 28 GridEngine, LOD3

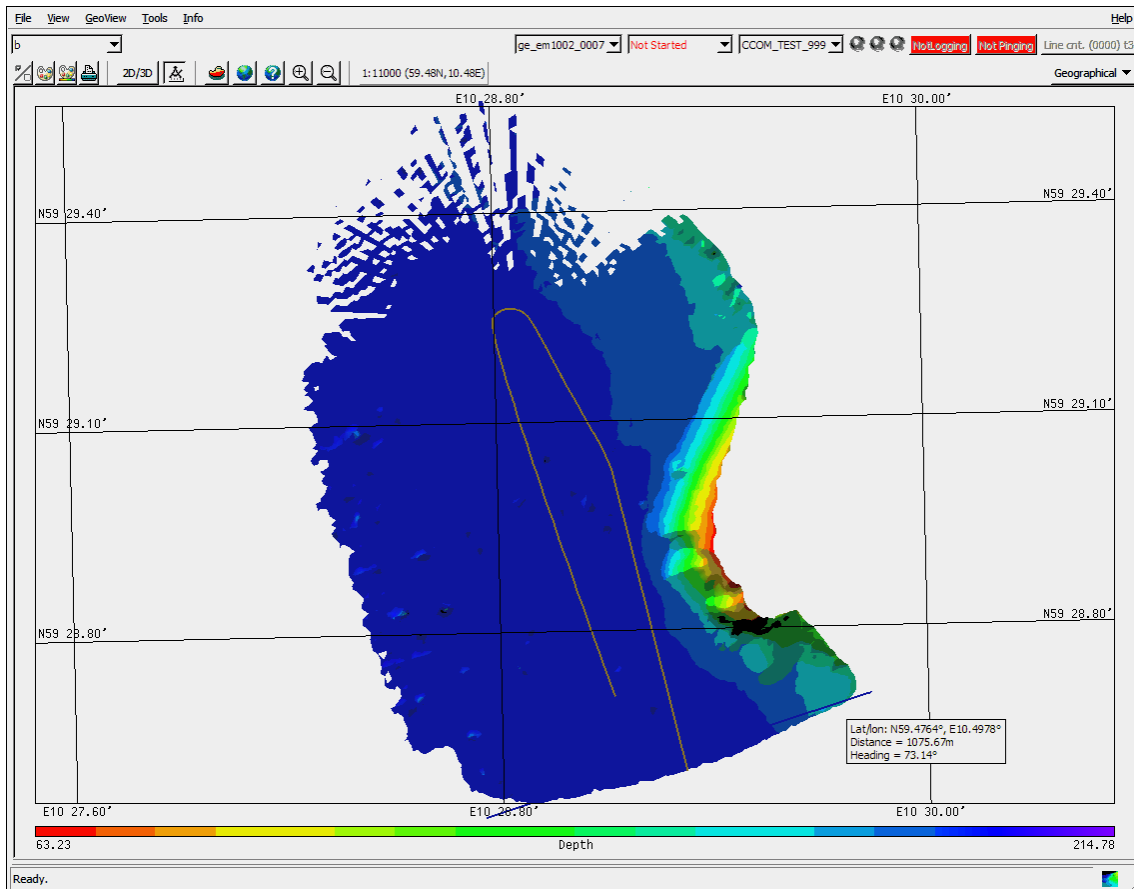

Figure 29 GridEngine, LOD1

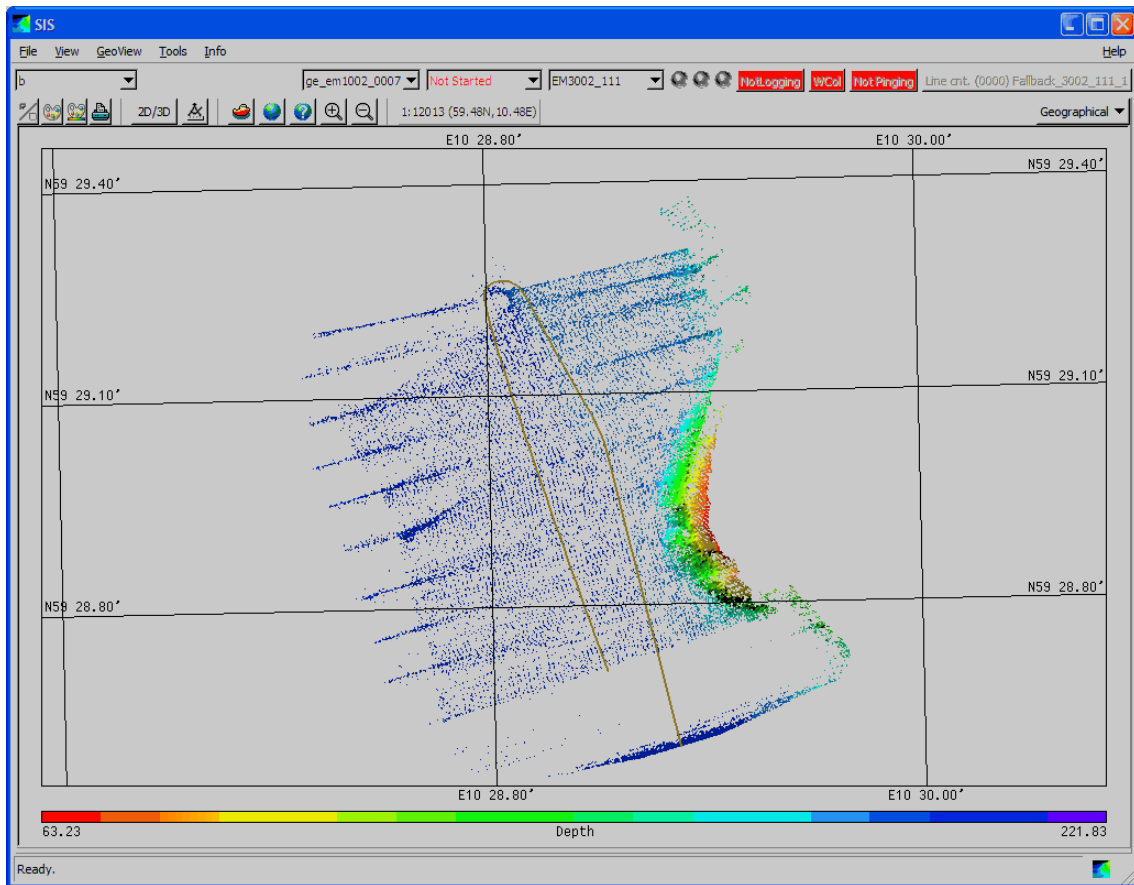

Figure 30 CUBE, grid cell size 10 m

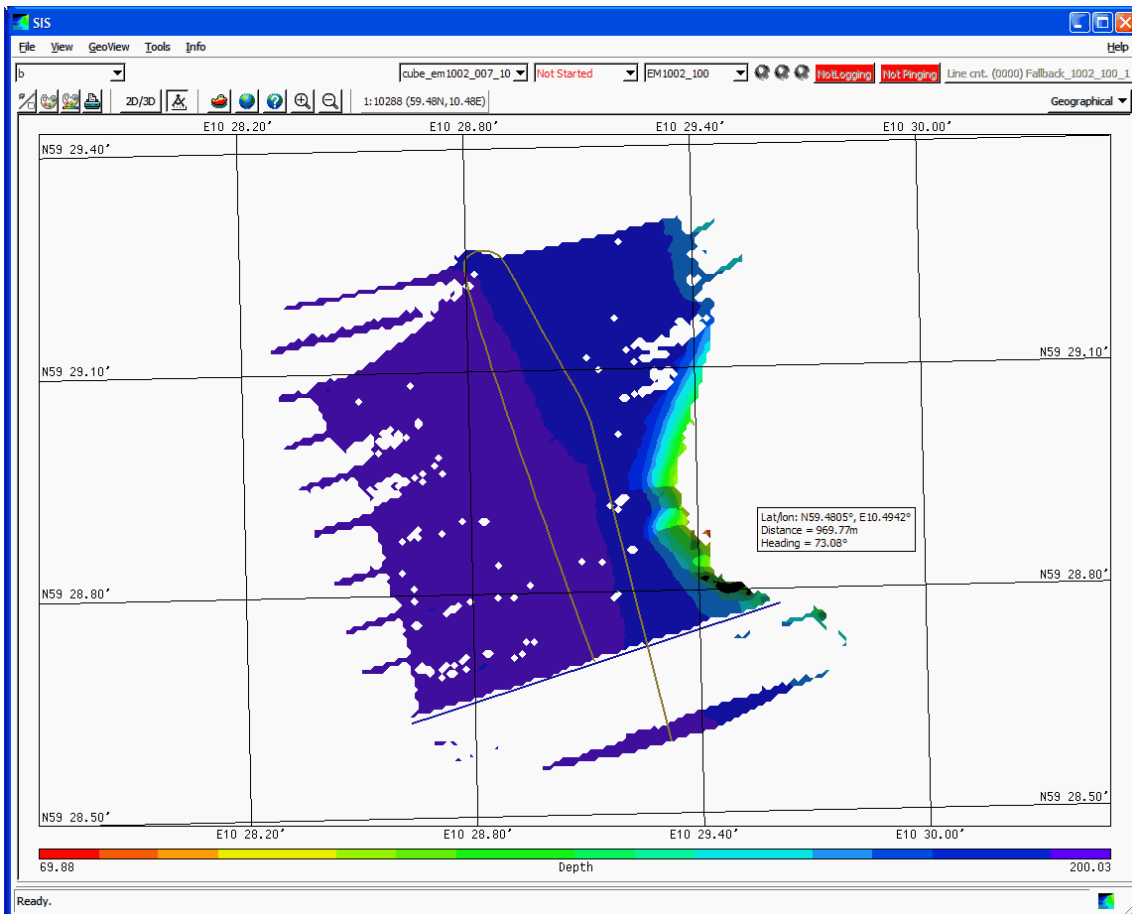
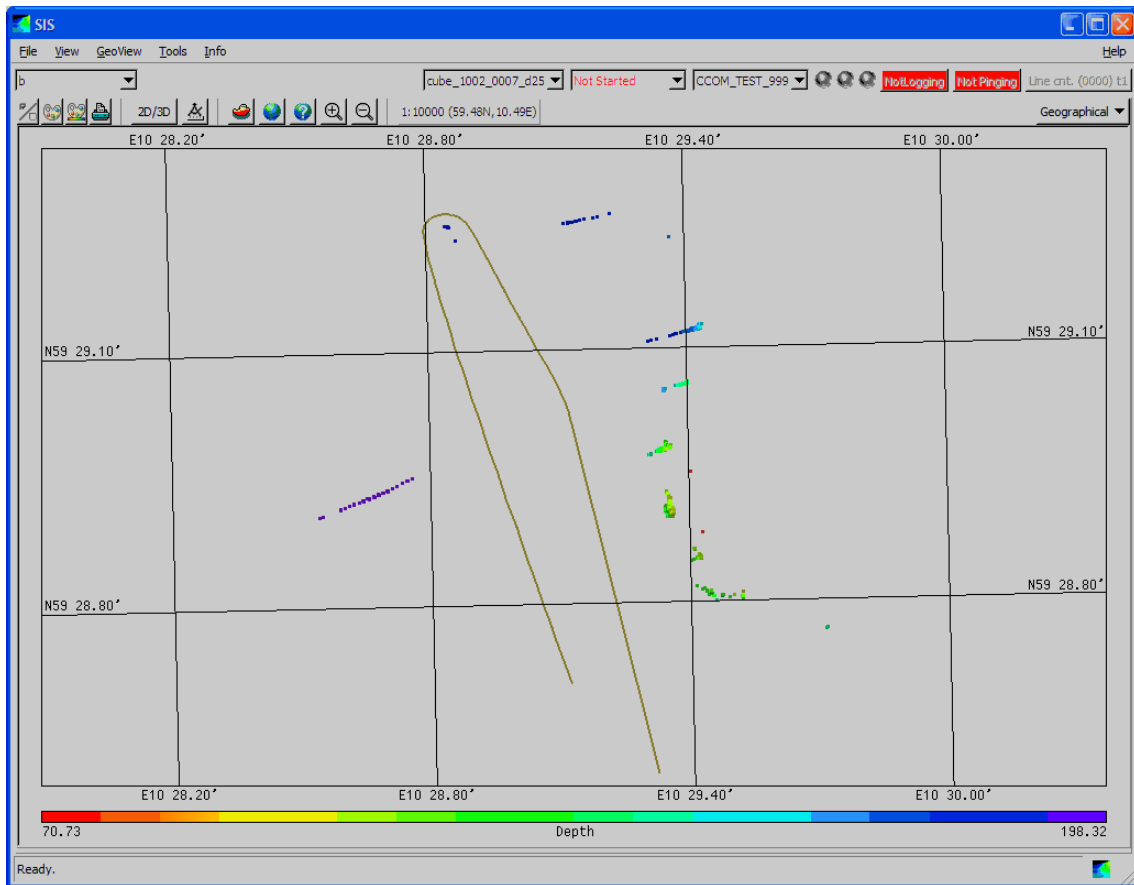

Figure 31 CUBE, grid cell size 2.5 m



CUBE also need some amount of data density to do the gridding. The grid in the next figure is from one survey line. The grid width is measured to 19 metres. With one more survey line the same distance is measured to 32 metres.

Figure 32 Grid width 19 m

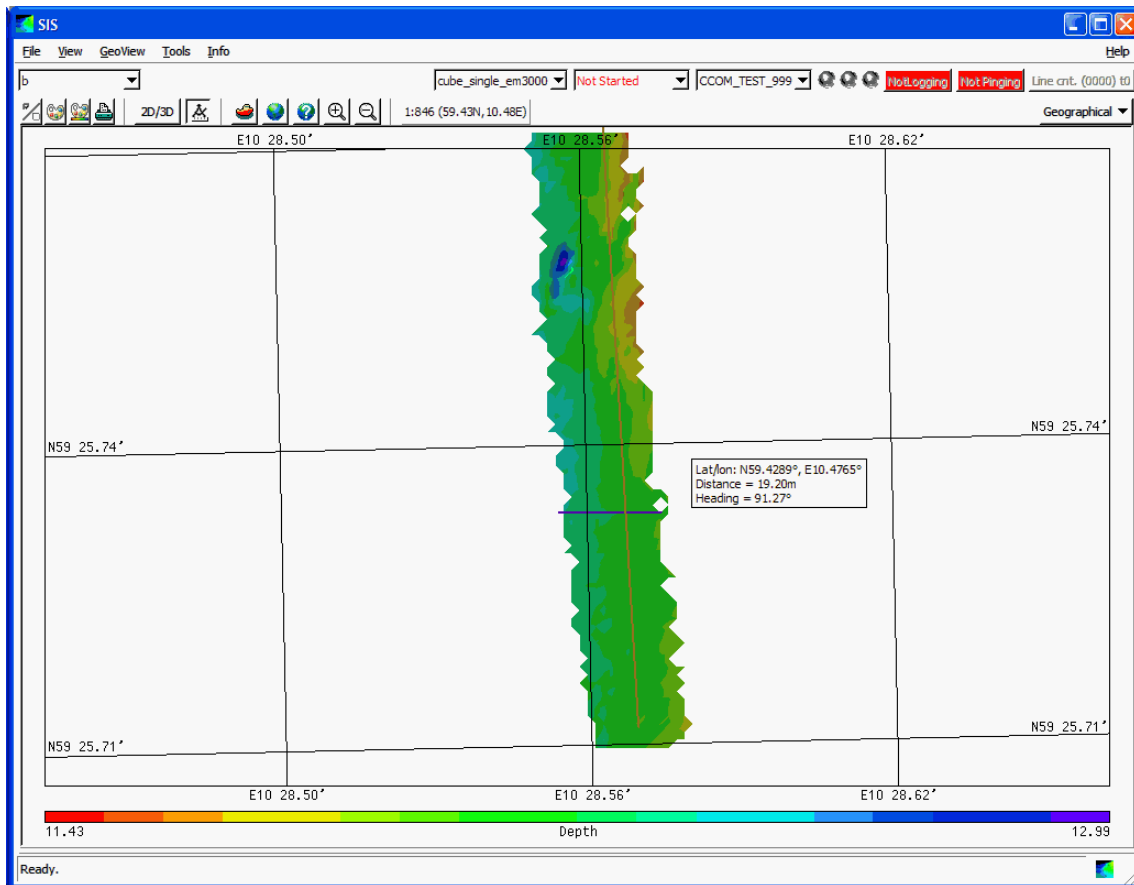
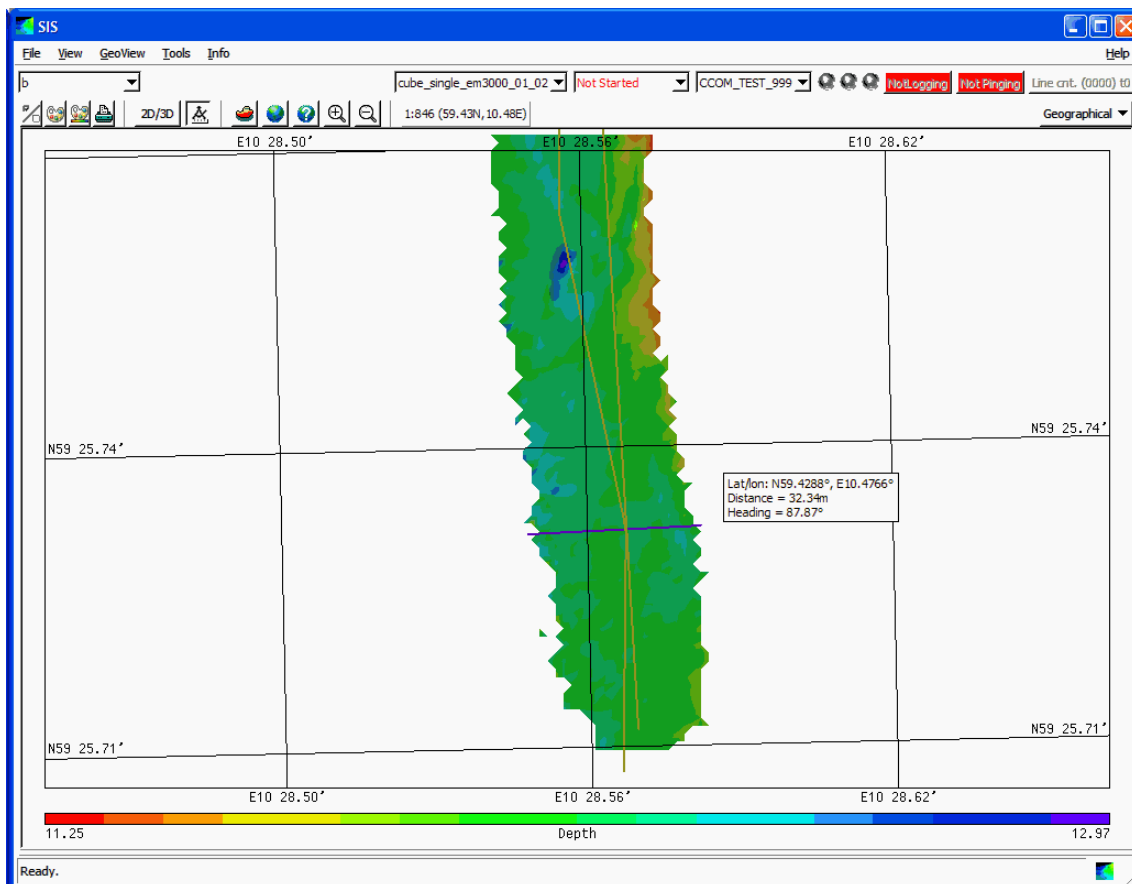

Figure 33 Grid width 32 m



In SIS only depth are extracted from the CUBE processed data. In addition to the depth, CUBE can return uncertainty, number of hypothesis and hypothesis strength in each grid node.

User interface differences when CUBE is used

Only the differences in the user interface between CUBE and the GridEngine is treated hereafter.

Import raw data

Please refer to *Import/Export* on page 352 for details.

The parameters for the gridding is entered in the window at the bottom of the **File**→**Import/Export...**→**Raw Data Files** user interface.

Figure 34 Raw data import - CUBE parameters

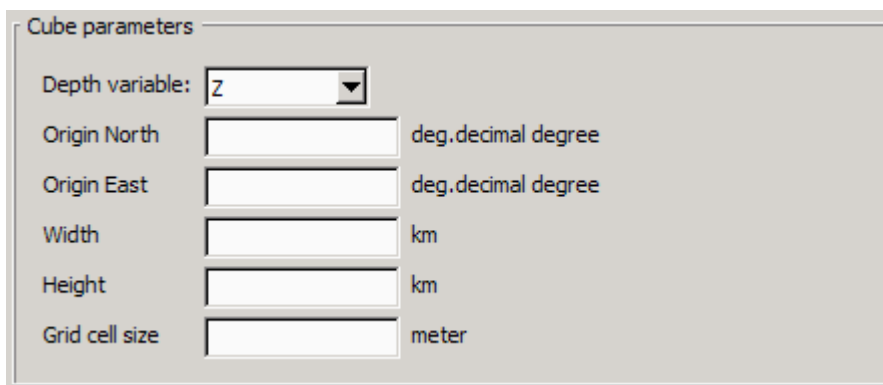

Cube parameters		
Depth variable:	<input type="text" value="Z"/>	
Origin North	<input type="text"/>	deg.decimal degree
Origin East	<input type="text"/>	deg.decimal degree
Width	<input type="text"/>	km
Height	<input type="text"/>	km
Grid cell size	<input type="text"/>	meter

CUBE needs to know the geographical coordinates of the survey area before any processing can start. The centre location for the grid width, height and cell size must be given. Western or southern values have to be entered as a negative value.

A large survey area requires a coarser grid cell size. You are notified if the grid size is too small for the requested survey area. In that case the grid size has to be increased or the survey area has to be reduced.

Export CUBE Survey data

GridEngine surveys can be exported to ASCII-files, which can be imported in Neptune. This feature is not supported for CUBE generated grids.

The CUBE grids are however stored as GUTM-files on disc.

See

<http://www.ccom.unh.edu/vislabs/GeoZui3D/FileFormats.html#GUTM>

for a specification for the file format.

Figure 35 CUBE Export options

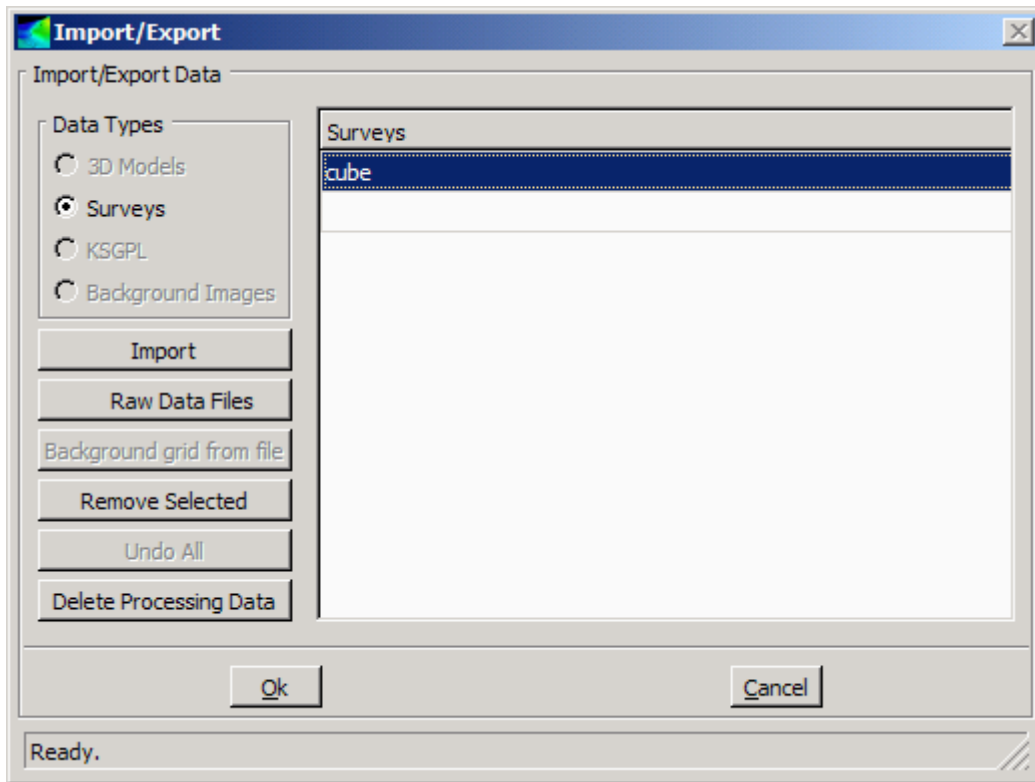
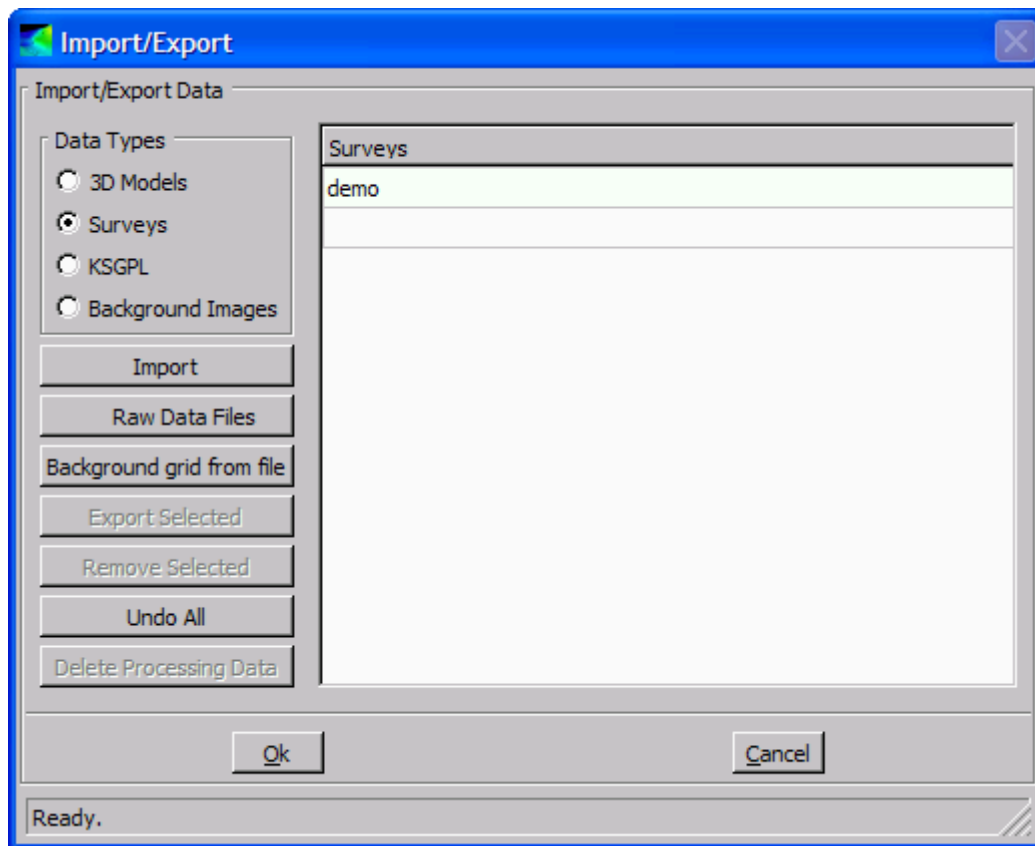

Figure 36 GridEngine Export options



CUBE Geographical window

The **Geographical** window in CUBE mode differs slightly from that of the GridEngine mode. Instead of the **Option** button as used in GridEngine mode, the Geographical options in CUBE mode are set using the **Show/Hide** button.

The main menu in CUBE mode also holds a **Geographical menu** which is not found when in GridEngine mode.

The **Show/Hide** button together with the **Geographical menu** in CUBE mode give the same options as found in the **Geographical Option** button in GridEngine mode. However, CUBE holds less options as fewer features are supported.

Show/Hide button



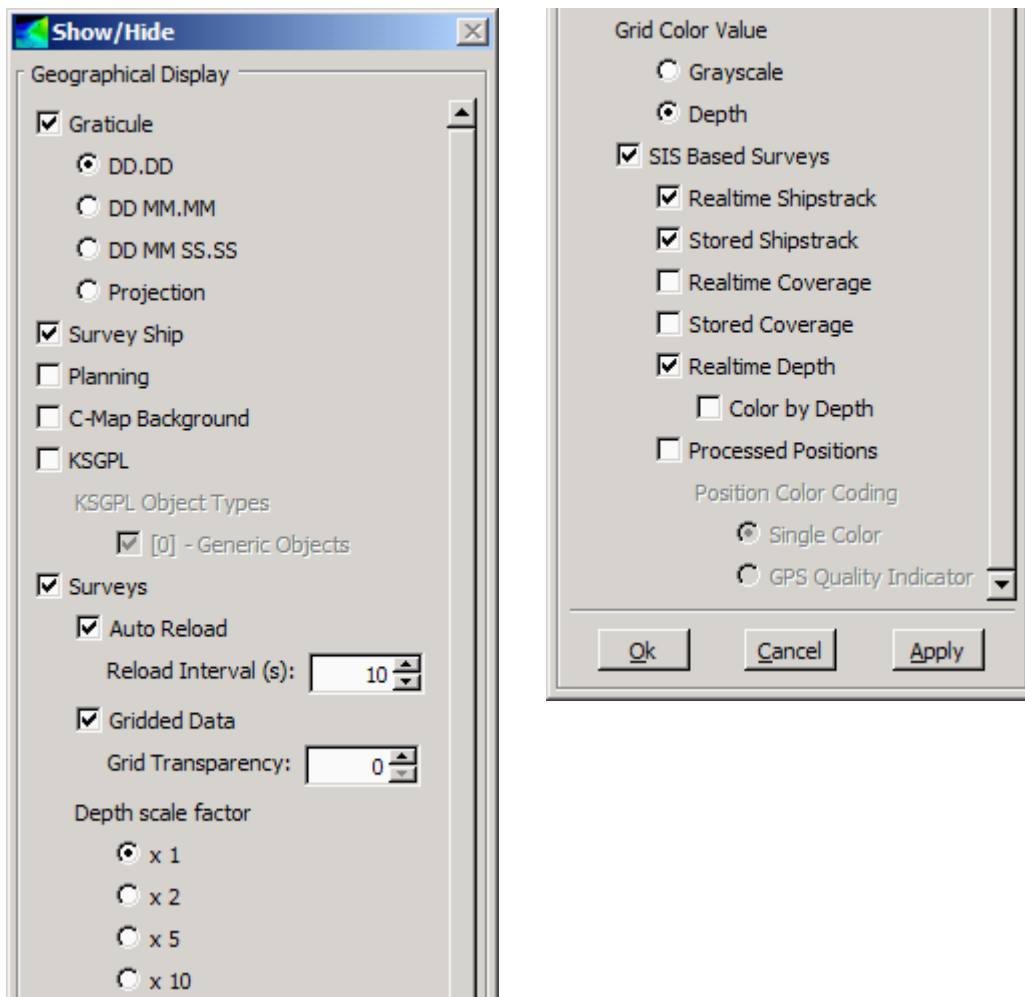

Geographical menu

The Geographical menu holds the following parameters:

- **Light Source:** To set the light source for the geographical display
- **Grid:** To set parameters for how to present the CUBE grid, i.e.
 - Drawstyle (points, triangles, filled, text and text overlay)
 - Shading (on/off)
 - Triangulation (centre or true point)
 - Smoothing (Level 0 to Level 3)

Level of detail

The GridEngine has six **Levels Of Details, LOD**, in its display grid. For CUBE only the processing grid is available for display and the choice is removed from the user interface.

Dynamic colors

For CUBE grids, only depth can be used as a colour map for the **dynamic colours**.

Related topics

- *Geographical view* on page 57
- *Main menu* on page 103

Other functions not supported by CUBE**Calibration**

This is not available when using CUBE. The GridEngine must be run to calibrate the echo sounder.

Projection

CUBE grids in SIS can only hold UTM projected data.

Related topics

- *Calibration view* on page 100
- *Projection and datum parameters* on page 384

Precise Point Positioning (PPP) in SIS

Precise Point Positioning in SIS is a set of utility programs to SIS that gives you the opportunity to apply precise GPS orbit and clock correction data to your GPS raw data to obtain position accuracy in the centimetre to sub-decimetre range. The post processed positions are made available through an updated position data file in the KM binary file format.

The following steps will provide you with sub-decimetre position data:

- 1 Logging of dual frequency GPS data in the RTCM 3.0 format (from the Seapath 300 system)
- 2 Automatic formatting of the GPS raw data into RINEX format
- 3 File handling to prepare for post processing
- 4 Running the PPP software (TerraPOS) to obtain the high precision positions

Note

*PPP in SIS can currently be applied to raw data from the Seapath 300 dual frequency GPS receiver. The term **GPS** is therefore used when referring to the PPP application in SIS, whilst the **GNSS** term, which is the general term for all Global Navigation Satellite Systems (including GPS, Glonass, EGNOS, etc) is used in the general descriptions.*

Topics

- *Precise Point Positioning (PPP) – General description on page 476*
- *TerraPOS on page 477*
- *How to do Precise Point Positioning in SIS on page 478*

Precise Point Positioning (PPP) – General description

Precise Point Positioning (PPP) is a method that performs precise position determination using a single GNSS receiver.

The approach is to apply GNSS orbit and clock data products with centimetre accuracy to reduce the errors in the broadcasted GNSS satellite orbits and clocks, two of the most significant error sources in GNSS positioning. Combining precise satellite positions and clocks with a dual-frequency GNSS receiver (to remove the first order effect of the ionosphere) and advanced modelling of other error sources in the GNSS observables, PPP is able to provide position solutions in the centimetre to sub-decimetre level.

PPP is different from RTK and traditional DGNS in that there is no need for data from local or regional reference stations.

Precise post processed orbit and clock data are determined by e.g. NASA's Jet Propulsion Laboratory (JPL) and available from e.g. the International GNSS Service (IGS). The correction data is freely available for download via the Internet.

The accuracy and reliability of the clock and orbit data depends on the age of your data. The longer you await the post processing, the higher accuracy and reliability the available clock and orbit data will have. The table below shows the expected latency

before the results of various IGS processing levels becomes available. The highest possible accuracy and reliability **Final** data is available after 12 to 18 days after your data was logged. The quoted accuracy for **Rapid** data that is available after 14–41 hours is the same as for the final data, but with slightly smaller reliability figures.

Refer to table below for accuracy figures for 2009, or refer to the IGS Products on <http://igsceb.jpl.nasa.gov/components/prods.html> for updated figures.

Table 3 IGS Product Table – updated for 2009

GPS Satellite clock and orbit data	Latency	IGS quoted accuracy	
		Orbits	Satellite clock
Broadcast	real time	~ 100 cm	~ 5 ns RMS / 2.5 ns sDev
Ultra-rapid (predicted half)	real time	~ 5 cm	~ 3 ns RMS / 1.5 ns sDev
Ultra-rapid (observed half)	3–9 hours	~ 3 cm	~ 150 ps RMS / 50 ps sDev
Rapid	14–41 hours	~ 2.5 cm	~ 75 ps RMS / 25 ps sDev
Final	12–18 days	~ 2.5 cm	~ 75 ps RMS / 20 ps sDev

The clock and orbit correction data can be applied to GNSS raw data logged in the RINEX format.

TerraPOS

The Precise Point Positioning utility in SIS makes use of the **TerraPOS** software developed by TerraTec AS. **TerraPOS** is a GNSS (GPS+Glonass) post processing software that makes use of GNSS raw data files and precise post processed orbit and clock data to compute accurate positions.

To use the TerraPOS software, the following conditions must be recognized:

- TerraPOS is based on post processing, the accurate positions is not available online
- Your post processing computer must have an Internet connection to download the precise clock and orbit data
- Dual-frequency GNSS data is required
- Due to the nature of GNSS phase measurements, where the phase's integer ambiguities must be estimated, a certain time span of continuous observations must be allowed for before the highest accuracy requirements are met. For Precise Point Positioning in SIS 30 minutes of extra data is recommended.
- Obtained accuracy depends on satellite geometry and signal reception conditions
- Observations must be provided in RINEX format

Please refer to www.terratec.no for further details.

In SIS the TerraPOS user interface is hidden to the user.

How to do Precise Point Positioning in SIS

In SIS the following steps will provide you with sub-decimetre position data:

- Logging of dual frequency GPS data
See *Logging raw data* on page 478
- Run the post processing software **Terrapos Manager** to manage the raw data files and to compute the accurate positions
See *Terrapos Manager* on page 479.

Logging raw data

Precise Point Positioning in SIS can be used if you have a dual frequency GPS receiver capable of supplying GPS raw data in the **RTCM 3.0 standard** raw data format.

Note

The RTCM SC-104 standard applies to Differential Global Navigation Satellite Systems (DGNSS). Version 3 was developed for RTK operations, i.e. raw data that includes phase observables.

The dual frequency GPS receiver **Seapath 300** will output GPS raw data to SIS in the required RTCM 3.0 format.

The name of the logged RTCM file has the following format:

```
RTCMYYYYMMDD_HHMMSS.rtcM
```

where the date and time is the current UTC time at the time of file creation.

The format of the information stored in the file is the length of the received signal (unsigned short, i.e. 2 bytes) and then the signal itself.

Each logged **.rtcM** file is automatically formatted into a **RINEX** (ASCII coded satellite position data) **.08o** file as soon as a log file is closed after a user entered period. This formatted file will be used in the post processing. The original **.rtcM** file is retained. The naming format of the RINEX file is

```
YYYYMMDD_HHMMSS.08o
```

where the date and time is fetched from the first datagram in the file.

Note

RINEX – Receiver Independent Exchange Format is a standardized data interchange format for raw satellite navigation system (GNSS) data that often is used in post processing. The RINEX format allows the raw GNSS data to be post processed using different methods, independent of product type and software, and correction data that origin from elsewhere than the original receiver can be applied.

More informations

- *GPS and delayed heave* on page 323

Terrapos Manager

Terrapos Manager is the name of the SIS application that assists in applying clock and orbit correction data to your GPS raw data. The **Terrapos Manager** performs the following automated processes:

- Locates and copies the RINEX raw data files along with the survey definition data from the survey computer to a portable storage device, such as a USB memory stick
- Copies the RINEX raw data files from the portable storage device to the correct location on the post processing computer
- Runs the **TerraPOS** post processing application using precise clock and orbit data fetched via the Internet.

Terrapos Manager

Terrapos Manager is opened by selecting **Tools**→**Custom...**→**TerraPos Manager** from the SIS main menu.

The following dialog opens.

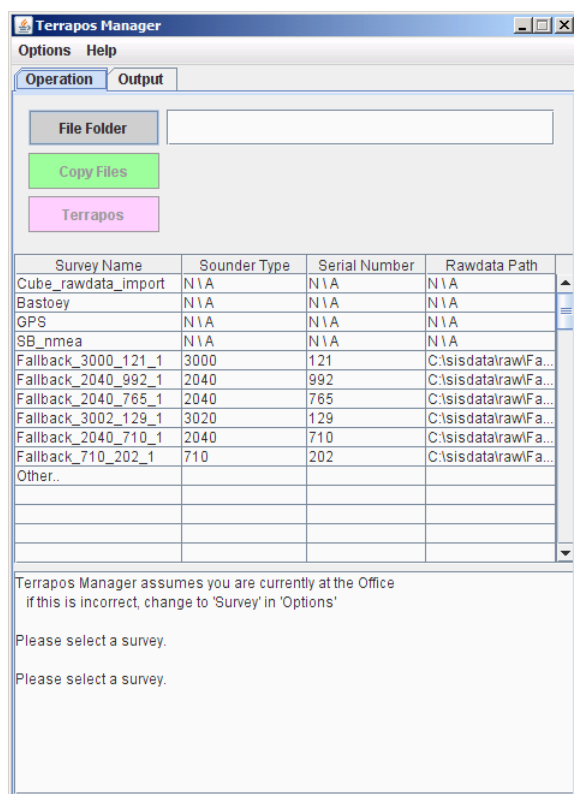

The software will perform a search for Internet access. If Internet access is found, the program will assume it is being run from the *Office* and prepare for running the Terrapos application. If Internet access is not found it will be assumed that it is being run from the *Survey* computer and prepare for copying data from the computer to a memory stick.

Terrapos Manager menu

The main menu of Terrapos Manager holds the following selections:

- Options
- Help

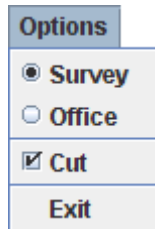

The **Options** menu contains the following:



- **Survey/Office:** If you need to force the program into either *Survey* or *Office* mode, select **Options** from the **Terrapos Manager** main menu and tick off **Survey** or **Office** as appropriate.
- **Cut:** The raw data is by default **Cut**, i.e. deleted from original source as they are copied onto the destination. If you do not want to remove the data from its original storage, deselect **Cut** from the **Options** menu.
- **Exit:** Closes **Terrapos Manager**.

The **Help** menu contains a labelled sketch description **Terrapos Manager**.

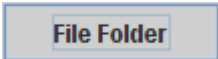
Terrapos Manager buttons

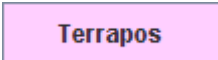
Select	To
	Browse for the portable storage device to copy raw data to or from, depending on whether you are in <i>Survey</i> or <i>Office</i> mode.
	Start copying the files. The button will be disabled until a valid survey containing RINEX raw data is selected.
	Start the Terrapos application, i.e. start generating the post processed position data file.

Survey selection list

Survey Name	Sounder Type	Serial Number	Rawdata Path
Cube_rawdata_import	N/A	N/A	N/A
Bastoe	N/A	N/A	N/A
GPS	N/A	N/A	N/A
SB_nmea	N/A	N/A	N/A
Fallback_3000_121_1	3000	121	C:\sisdata\raw\Fa...
Fallback_2040_992_1	2040	992	C:\sisdata\raw\Fa...
Fallback_2040_765_1	2040	765	C:\sisdata\raw\Fa...
Fallback_3002_129_1	3020	129	C:\sisdata\raw\Fa...
Fallback_2040_710_1	2040	710	C:\sisdata\raw\Fa...
Fallback_710_202_1	710	202	C:\sisdata\raw\Fa...
terratest			C:\sisdata\raw\ter...
Other..			

- Select **Survey name** from the list of surveys found in the database of SIS running on your computer. Selecting the survey will tell **Terrapos Manager** what survey parameters to apply during post processing.
- **Other...:** You can also select a survey that is not loaded in the SIS database by selecting a folder with `.all` files corresponding to the RINEX files. Click **Other...** to browse for the `.all` folder to select survey information from.
- **Output:** If you select the **Output** tab all internal activity of the program will be displayed.

Status display

```

Go to office-mode to run Terrapos
You may copy the files.

Selected folder contains Seatec files
You may run Terrapos
Processing.. please wait!

Finished. See survey folder for resulting files.
If Terrapos was successful, a *.terrapos file was created and a copy of it
can be found in the Rawdata Path

```

This window will display information related to current status of Terrapos Manager.

The output tab

In the output tab view all internal activity of the program will be displayed.

How to copy the raw data files from the survey computer to a USB memory stick

- 1 Browse for the memory stick storage location to copy data to by pressing the **File Folder** button.
- 2 Select correct survey from the list
or
Select **Other...** to browse for the raw data folder for that survey
- 3 Press the **Copy files** button.
Program status will be shown in the status window.

Note _____

*If you would like to follow into details the program's processes, go to the **Output** tab.*

When all files have been successfully copied the following message will be displayed in the status window:

```
FILES COPIED SUCCESSFULLY FROM <from_folder> TO
<to_folder>
```

- 4 Remove the USB memory stick.

How to copy the raw data from the USB memory stick to the post processing computer

1 Browse for the memory stick storage location to copy data from by pressing the **File Folder** button.

2 Press the **Copy files** button.

Program status will be shown in the status window.

Note _____

*If you would like to follow into the program's processes details , go to the **Output** tab.*

When all files have been successfully copied the following message will be displayed in the status window:

```
FILES COPIED SUCCESSFULLY FROM <from_folder> TO  
<to_folder>
```

3 Press the **Terrapos** button to start position post processing using the Terrapos application.

Note _____

A Terrapos license along with a full SIS installation is required.

Program status will be shown in the status window.

Note _____

*If you would like to follow the program's processes into details , go to the **Output** tab.*

When completed the following message will appear in the status window:

```
Finished. See survey folder for resulting files.
```

```
If TerraPOS was run successfully, a *.terrapos file was  
created and a copy of it can be found in the Rawdata  
path.
```

4 Use Windows Explorer to verify that the `.terrapos` files is copied to

```
\sisdata\survey\<<survey_name>\Terrapos\<<input_file_names>\  
and to \sisdata\raw\<<survey_name>.
```

Also note that in the

```
\sisdata\survey\<<survey_name>\Terrapos\<<input_file_names>\  
the Terrapos generated files are stored. These are:
```

- *.clk, *.eph and *.erp files. These are the clock and orbit correction files that are downloaded from the Internet.
- The merged RINEX file used as input to the Terrapos calculations
- A Terrapos generated log file containing summary of the computation results, including statistical figures that may give you required quality control.

GSF support in SIS

SIS supports the Generic Sensor Format (GSF) from [SAIC](#). The .all-files can be converted to this format using the tool **GSF Converter**.

Topics

- *How to use GSF Converter* on page 483

How to use GSF Converter

The **GSF Converter** is started by running the file `GSF_converter.exe` located under `C:\Program Files (x86)\Kongsberg Maritime\SIS\Gsf`

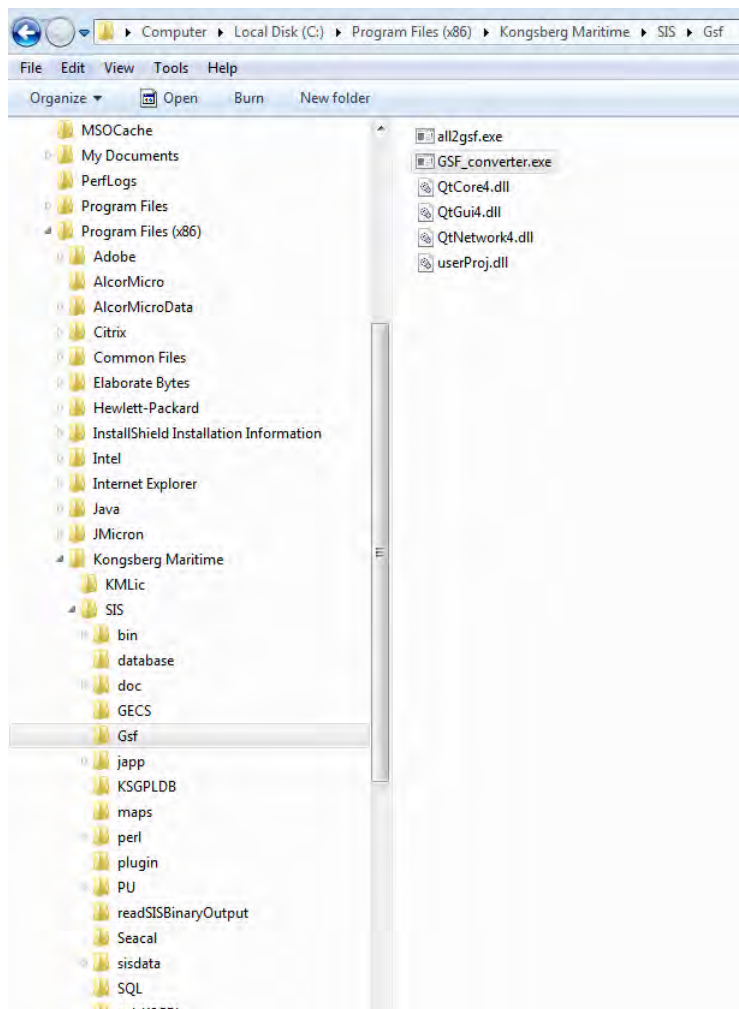

Click **Select raw data directory...** and select the directory containing the .all-files.

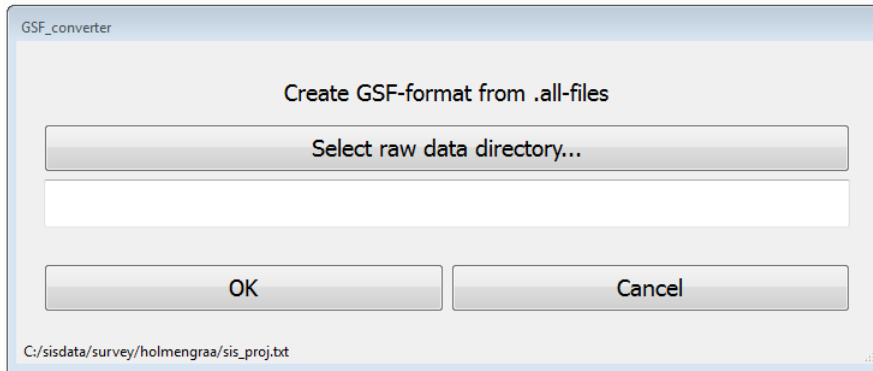

Note

Note that the file `sis_proj.txt` must be present in the directory containing the .all-files, and it must contain a projection named `SIS_Projection`:

```
<SIS_Projection>
ellps=WGS84
proj=utm
zone=32
north
units=cm
```

If the file `sis_proj.txt` is missing from the directory, an error message is displayed.

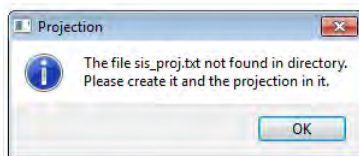

The file `sis_proj.txt` is normally created when defining a survey in SIS, you can copy it from a SIS-survey and rename the projection in that file.

The program `all2gsf` will traverse the directory tree and convert all files found using the same projection file for all files. This makes it possible to convert many surveys in one operation.

In addition to the GSF-files, a file with the suffix `.ext` is created. This file contains extra information that may be helpful when reading the GSF-files back:

The GSF-files uses relative positioning for the soundings. Each ping has a position in latitude and longitude, and then the position to each sounding is given as along and across distance from that position. To convert along and across back to latitude and longitude, SIS uses two factors. Multiplying the delta values in the GSF with these factors, will give the correct latitude and longitude. Note that the factors in the file converts between degrees and centimeters, and the GSF uses meters.

GSF specifies the time in seconds since epoch. To be sure there are no errors done when converting back to the time in the .all-file, SIS outputs the time in the .all-file of some soundings in the file. These can be used to verify that the time has been converted correctly back to the time in the .all-files. Here is an example of an .ext-files:

```
11141696.406487 5533467.822988 20081128 70856007
11141698.467512 5533261.885997 20081128 70916165
11141700.455559 5533063.233643 20081128 70976414
11141702.530323 5532855.908620 20081128 71036828
11141704.637373 5532645.349463 20081128 71097227
11141704.637373 5532645.349463 20081128 71097227
```

The first ping is always written, and the last ping twice. Then there is one line with approximately one minute between the positions.

The first number is the factor used to convert between centimeters and degrees latitude, the second is the factor to convert centimeters to degrees longitude. Then comes the date in YYYYMMDD format, and then the milliseconds since midnight that day.

SIS calculates these factors for every ping, but these files only contain these factors with a one minute resolution.

The depths have been corrected using the WGS 84 datum which should be applicable even if other datums are used by the positioning system. This means that there is no need for further datum corrections in these GSF-files.

Kongsberg Maritime can assist with source code examples showing how to read the GSF-files correctly using the extra safety in the .ext-files. Please contact Customer Support if this is needed.

Technical references

This chapter provides basic reference information useful to understand settings and parameters used throughout the SIS system. The chapter is intended for users who would like a deeper knowledge of the technical background for and the data flow inside SIS.

Topics

- *SIS architecture* on page 487
- *Real time data cleaning* on page 492
- *The vessel coordinate system* on page 496
- *Timing* on page 498
- *Sound speed formulas* on page 502
- *Implementation of absorption coefficients* on page 504
- *Artefacts causing errors and variations in the sea floor depth detections* on page 509
- *The absorption coefficient equation* on page 512
- *Projections* on page 513
- *Geoid* on page 515
- *Tide* on page 518
- *Javad and Trimble details* on page 520
- *Dead reckoning and position jump filter* on page 525
- *Checking of legal beam pointing angles* on page 527

SIS architecture

SIS processes

Figure 37 SIS main architecture

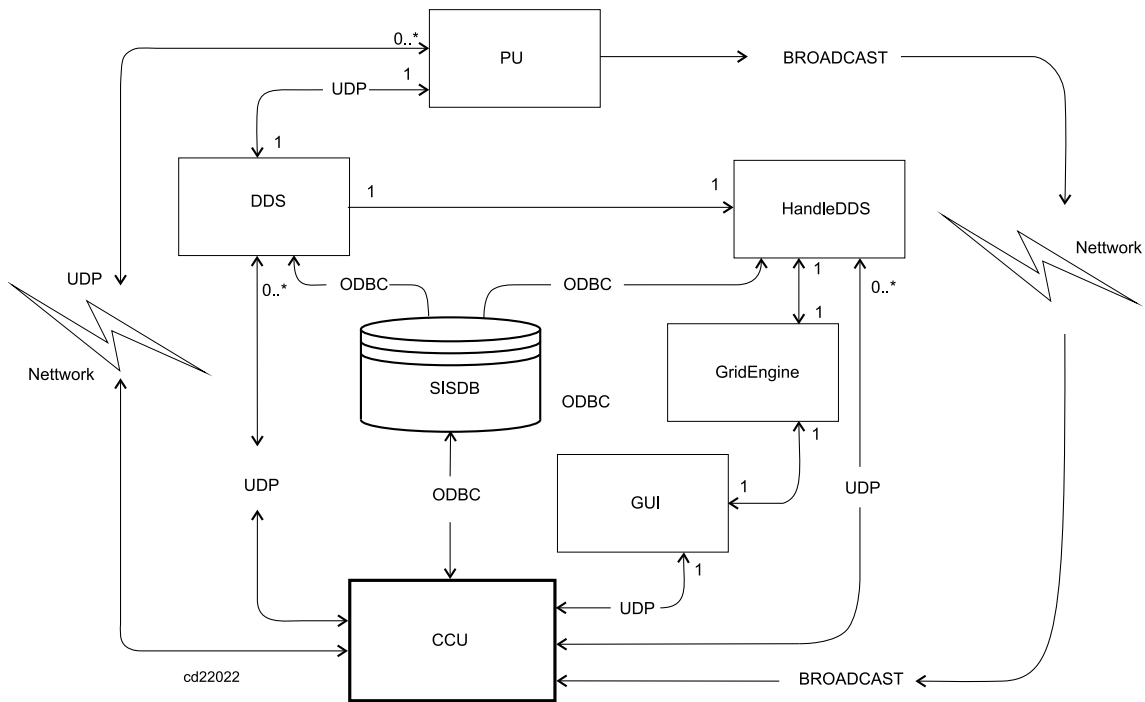

SIS contains six main processes. This is the start-up sequence:

- 1 The GUI is the main application, and is started first.
- 2 The CCU is started by the GUI. When the EM Processing Unit power is turned on it starts broadcasting messages on the network. The CCU will pick up these messages and display the EM availability in a list in the main GUI.
- 3 The operator chooses which echo sounders to start from the list in the main GUI.
- 4 The CCU will be informed which echo sounders to start, and then launch one DDS and one HDDS for each of the echo sounders.
 - The DDS reads datagrams received from the Processing Unit sockets and stores them as raw data on disk
 - The HDDS reads raw data from disk and generates xyz data that is sent to the GridEngine
- 5 The GridEngine receives xyz-data from the HDDS and generates a real time terrain model
- 6 The main GUI with the Geographical Display will now receive xyz-points from all echo sounders, and it will request the GridEngine for a terrain model to display.

Main GUI (Graphical User Interface)

The main application is called SIS and it contains the main graphical user interface (GUI).

There are three main tasks for the Main GUI:

- 1 To display the terrain model with quality information and provide a geographical view of the surveyed data
- 2 To display status information about the echo sounder
- 3 To control the echo sounder

Display and quality information in the Geographical view

The Geographical window gets xyz-data from the HDDS process. It will then display all these xyz-depths as they appear, but only the last pings will be shown. They will appear as a tail of soundings behind the ship.

The Geographical window also reads the terrain model generated by the GridEngine. The GridEngine contains five depth values for each observed depth. The user can choose which reference level to display.

The GridEngine also generates several levels of display detail, making it possible for the Geographical window to always display the most suitable level of details based on the current scale.

Note

The HDDS process reads data from the disk, meaning that the data displayed by Geographical window is just a subset of the raw data that remains safely stored on disk by the DDS process.

Status of the echo sounder

The Status windows get data directly from the echo sounders. This means that Status windows such as the Beam intensity window and Sound speed profile window all get the data directly. Hence the Status windows will be active when the echo sounder is active, and can always be used to monitor the current status of the echo sounder.

Controlling the echo sounder

Controlling and setting up the echo sounder is done by the Installation parameter window and the Runtime parameter window. Also Pinging, Logging and Line Counting will invoke the control of the echo sounder. Messages are not sent from the main GUI directly, but to the CCU process. The CCU is then responsible for sending the messages to the right echo sounder (remember that the CCU can control several echo sounders). See *CCU (Central Command Unit)* on page 489.

Messages concerning the system operation (errors, warnings, information) are stored in SISDB, and the main GUI provides a window where you can see all messages as they appear.

CCU (Central Command Unit)

The CCU process is responsible for detecting all echo sounders on the network, and to make sure that the communication is established between the different processes. Also, if a new echo sounder is found during rescan, the GUI will be informed.

DDS (Data Distribution System)

The DDS process is responsible for logging all the datagrams sent by the echo sounder. The CCU will tell the DDS where to store the data (complete filename). The DDS can also distribute datagrams to other processes on the network, both to SIS processes and to external processes. In SISDB you can define what datagrams to receive from the DDS process, and when to receive them (every time they come or with a certain time interval between).

HDDS (Handle Data Distribution System)

The HDDS process is informed by the CCU process where the DDS process stores it's files. The HDDS will read the raw data files and create xyz-data. For every depth observation the HDDS process will try to generate five depth types:

- Z: Depth, sea surface to seafloor distance
- Zt: Tide file corrected depth, vertical datum to seafloor distance
- Zv: Geoid and RTK corrected depth, vertical datum to seafloor distance
- Zg: Seafloor to geoid distance
- Zr: Seafloor to ellipsoid distance
- The depth measured by the echo sounder (waterline to seabed).

Note

If a tide file is available, look up the tide in that file and create a tide corrected depth.

If heights are available from a Real Time Kinematic GPS, and a geoid model is available, then the distance from the vertical reference to the sea floor will be generated. In addition, the distance from the sea floor to the geoid and the distance from the sea floor to the ellipsoid will be generated.

These depths will be sent to the GridEngine.

The HDDS will also read all the sidescan data from the echo sounder and make geo-referenced sidescan data (x, y, reflectivity). This is also sent to the GridEngine.

The HDDS process will do wild point editing of the positions (removing position jumps). Every position is converted from geographical coordinates to projection coordinates before it is sent to the GridEngine.

GridEngine

The GridEngine will receive data from both single beam echo sounders (EA) and multibeam echo sounders (EM). The data format is different in these cases. EA data is strictly xyz. This makes it possible for the GridEngine to read many kinds of xyz-data, and they may be from different sources such as ASCII-files. EM data is five depths for each measured depth, and optional sidescan data.

The GridEngine uses two different grids, one called Processing grid and the other is called Display grid. The Processing grid has a user defined resolution of its grid cells, and the user must define how many cells to keep in memory at one time. This is done by specifying the number of grid cells in x and y direction for the Processing grid. A maximum of four Processing grids can be stored in memory at any time.

The Processing grid will contain a lot of data: all the xyz-points and every xyz consists of five z-values. It will also contain all the sidescan data for all lines in that area, and it will keep track of which lines having data inside the area.

The Display grid is what the user actually sees. The Display grid is organized in a hierarchical tree structure called levels. The grid cell size of Level 0 of the Display grid is the same as the grid cell size of the Processing grid, so Level 0 Display grid will display everything from the Processing grid.

Level 1 in the Display grid is computed from four grid cells of Level 0, Level 2 is created from four cells of Level 1 and so on. All this is taken care of by the GridEngine.

The Processing grid is used in the Real Time Data Cleaning module, and the result is an updated Display grid. The Geographical window will calculate the maximum resolution necessary to display the data, based on the current map scale selected by the operator. In a very large scale (close view) Level 0 will be used, whilst in a smaller scale a higher Level of Detail will be used.

This means that the Geographical window will display only the necessary amount of data at any time, which again means that the rendering will be faster. The zoom and pan operations will also benefit, as the Geographical window will always get a pre-processed dataset to display.

The GridEngine is written in C# and is run as a standard application.

Note

A minimized console window is visible when SIS is running. This is where the GridEngine is running. Do not close this window!

Note

Grids created with the old Java based Grid Engine can not be imported using the new C# based GE.

SISDB

To store parameter settings used in SIS a database called SISDB is created. The database server is SQLite. Logged data is not stored in the database, only parameters settings and system messages.

This makes it possible to exchange data between different applications that use database, and to use standard applications and tools to browse the contents of the database.

Real time data cleaning

When data arrives the GridEngine, it may be cleaned in real time. Depths may be flagged out, but never deleted. Their status can always be changed if necessary. The Real Time Data Cleaning (RTDC) module operates in two steps:

- 1 As the data arrives, it will be organized as pings in an array. Then some processing will be carried out to these pings in the array. This is known as Line Based Data Cleaning (LBDC) because the processing only looks at data from current line. LBDC is not sufficient for proper data cleaning because errors caused by i.e. sound speed profiles will not be found. However, LBDC can be used for flagging out gross errors (spikes).
- 2 After LBDC the data will be put into the Processing grid. If you later return to the same survey area, the data from the previous lines will be read back and reprocessed together with the new data. This is called Area Based Data Cleaning (ABDC) because all data from the same area is processed together. ABDC makes it possible to find errors in e.g. sound speed profiles and installation angles.

Before starting the ABDC routine, the GridEngine will try to split and merge the processing cells into Cell Processing Units, which is used to create a surface. If a processing grid cell has very few points, it will be tried to merging it with its neighbour cells to create a bigger area with enough points. If there are too many points, the cell is split. The figure below shows examples of cells that are empty and cells that contain enough points. On the edge of the processing area there are some cells with too few points to do a good processing. The user can choose to automatically delete all points inside such cells.

Figure 38 Process grid split into processing units

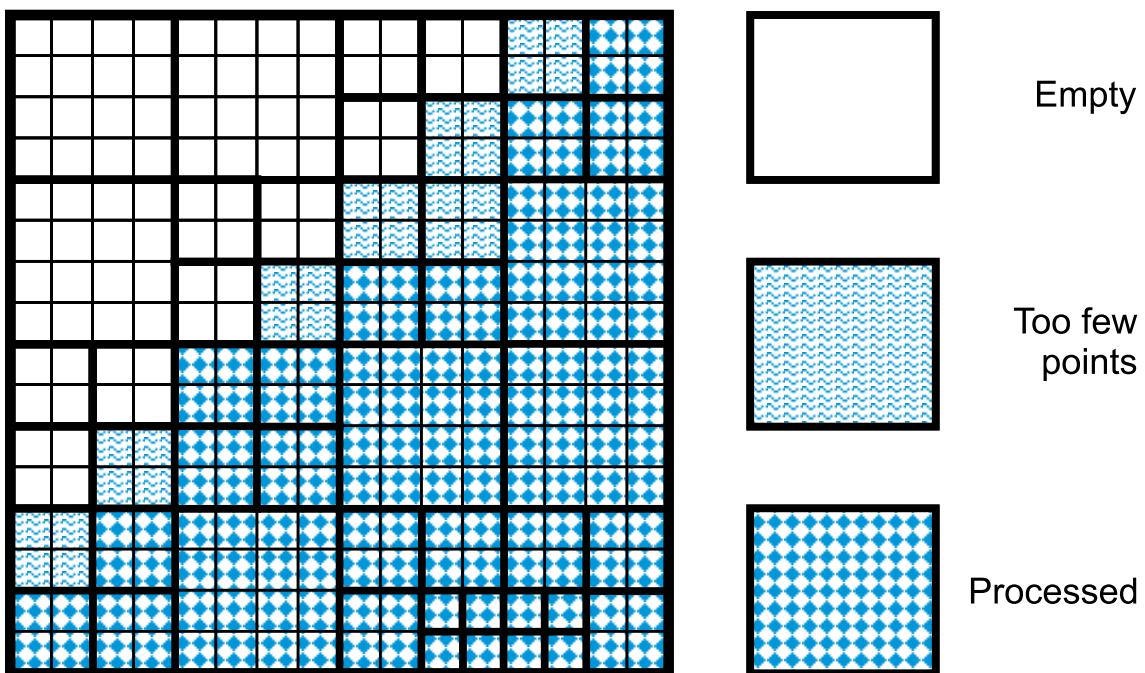

(CD6942)

The first thing to do in ABDC is to create a most likely reference surface in each processing unit. Traditionally this has been simply the mean depth value for the cell which means that the reference surface always will be a flat surface. In SIS the GridEngine constructs a much more reliable surface that will model the terrain much better. The surface is curved and constructed by using a first, second or third degree polynomial.

The method used to construct the reference surface is called Iterated Reweighted Least Squares (IRLS). The surface is created to be as close as possible to most of the points (best fit).

Figure 39 Best fit surface

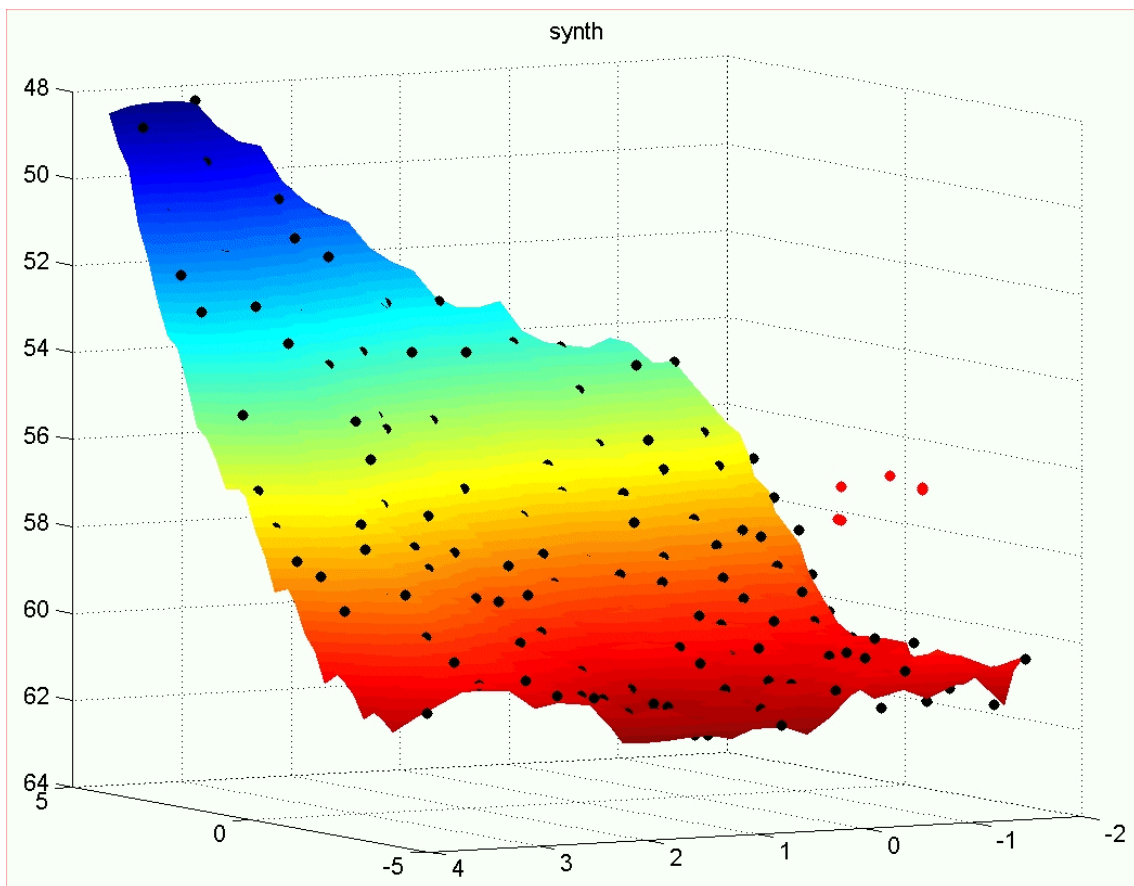

Each point is initially considered to be equally important. The algorithm assigns a weight to each point. All points get the same weight. Then a polynomial surface is created. The distance from each depth to this surface is called the residual. Then the sum of all the residuals is calculated. Since all points have the same weight, this sum is only the sum of the residuals.

Now the Tukey estimator kicks in. Rather than giving each point the same weight, each point gets a new weight based on how far away from the surface it is. Points far away from the surface get lower weight than the ones close to the surface. The parameter Tukey constant controls how fast points loose their weight. Below are some examples.

Note that the “r” in the figure below is the median residue in the Cell Processing Unit. As the “c” (Tukey constant) changes, the curve gets broader as “c” increases and narrower as “c” decreases. This means that points loose weight faster when the Tukey constant is small. The effect of losing weight fast is that points are not used in the construction of the surface the next time the algorithm is run.

Figure 40 Tukey algorithm

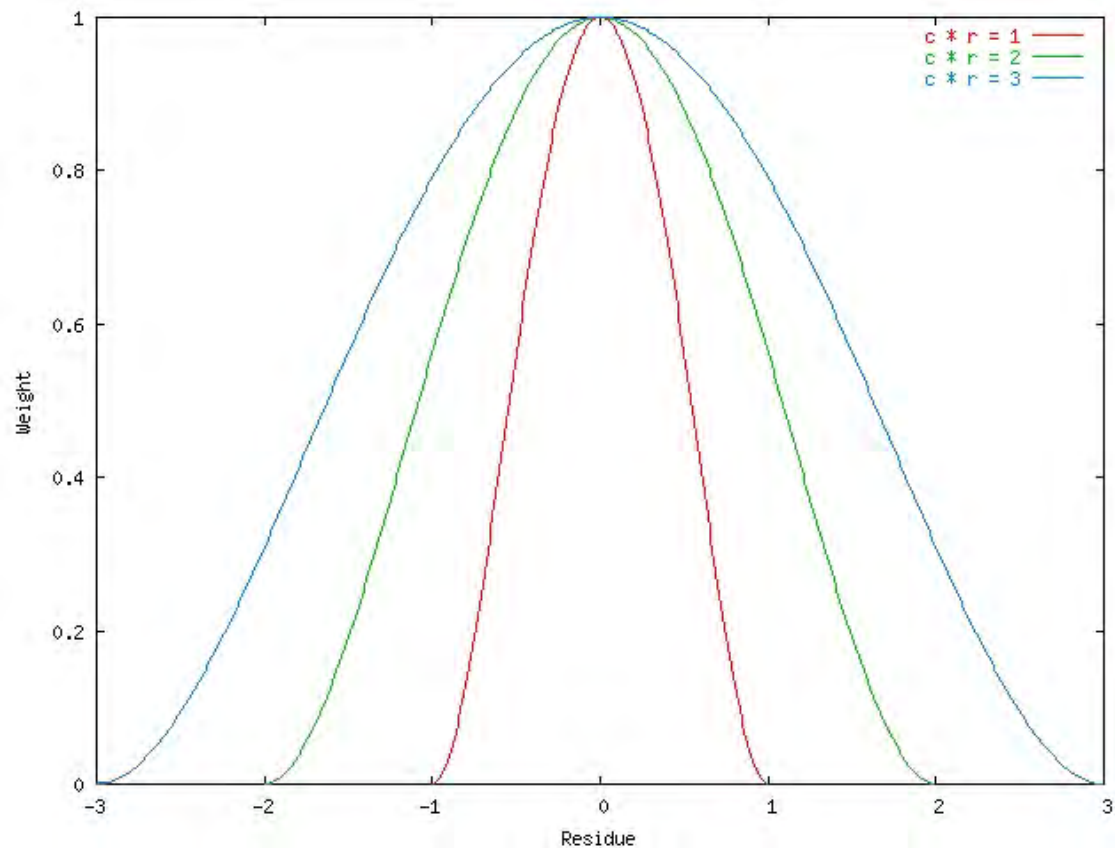

This algorithm will run several times and every time new weights are given to each point. There are two ways this algorithm will stop; Either it has tried Max. iteration of time to create a surface, or the change from previous run is very small. If this happens, the algorithm is said to converge, which means that the best possible result has been found. The parameter Conv. criterion controls when the algorithm converges.

To summarize, the algorithm for the Iterated Reweighted Least Squares (IRLS) method is given as follows:

- 1 Start with equal weights for all points
- 2 Loop until convergence or maximum iterations
 - a Fit the surface using weighted least squares
 - b Calculate residuals
 - c Check for convergence
 - d Adjust the Tukey estimator

e Evaluate new weights

When the polynomial surface has been successfully created, various rules can be applied to flag out depths.

Related topics

- *Data cleaning* on page 317

The vessel coordinate system

In order to relate the GPS antenna position to the seabed observations SIS needs to know the relative positions of the various sensors in use. This includes position sensors, attitude sensors and transducer heads.

The location of each sensor must be referred to a chosen reference point for the vessel. A cartesian right-handed coordinate system - as shown in the figure below - must be defined with its origin in the reference point. The location of this reference point has no physical significance - it may be anywhere on the vessel. The placement of the various instruments must be identified with forward, starboard and downward coordinates in this coordinate system.

Figure 41 The vessel coordinate system

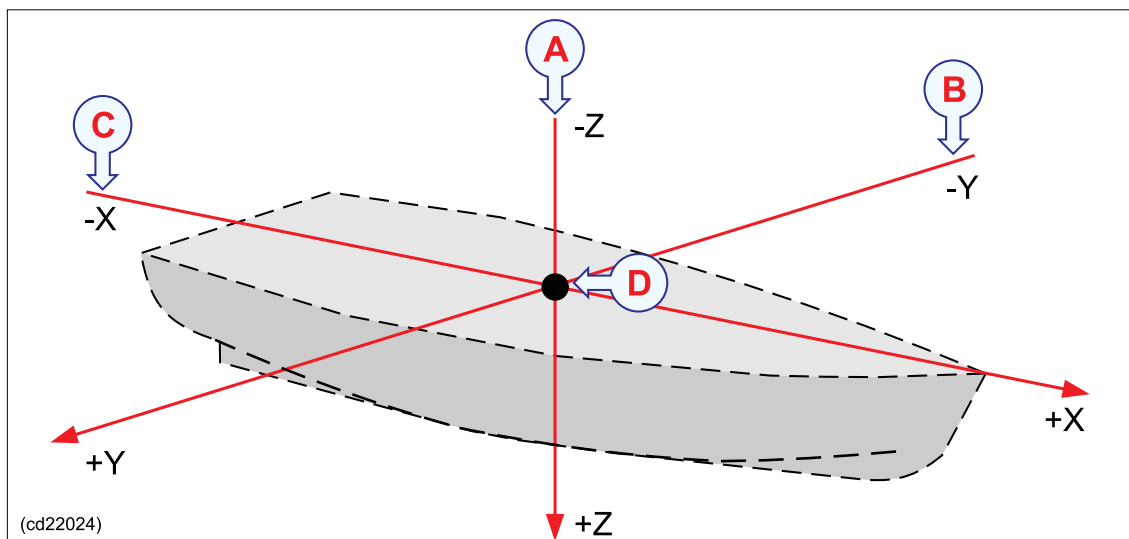

- A Downward position** is defined on the Z-axis (refer to the illustration above). Locations below the reference point are positive
- B Starboard position:** If a sensor location is on the starboard side of the reference point, the Y value will be positive.
- C Forward position** is defined on the X-axis (refer to the illustration below). Locations further forward than the reference point are positive.

The forward axis (X) must be parallel to the vessel keel, and the downward axis (Z) must be vertical when the vessel is trimmed normally. The plane defined by the forward and starboard axes will then be horizontal, and the attitude sensor should then, if properly installed and calibrated, measure zero roll and pitch with a normally trimmed vessel lying still.

Figure 42 Example of sensor locations

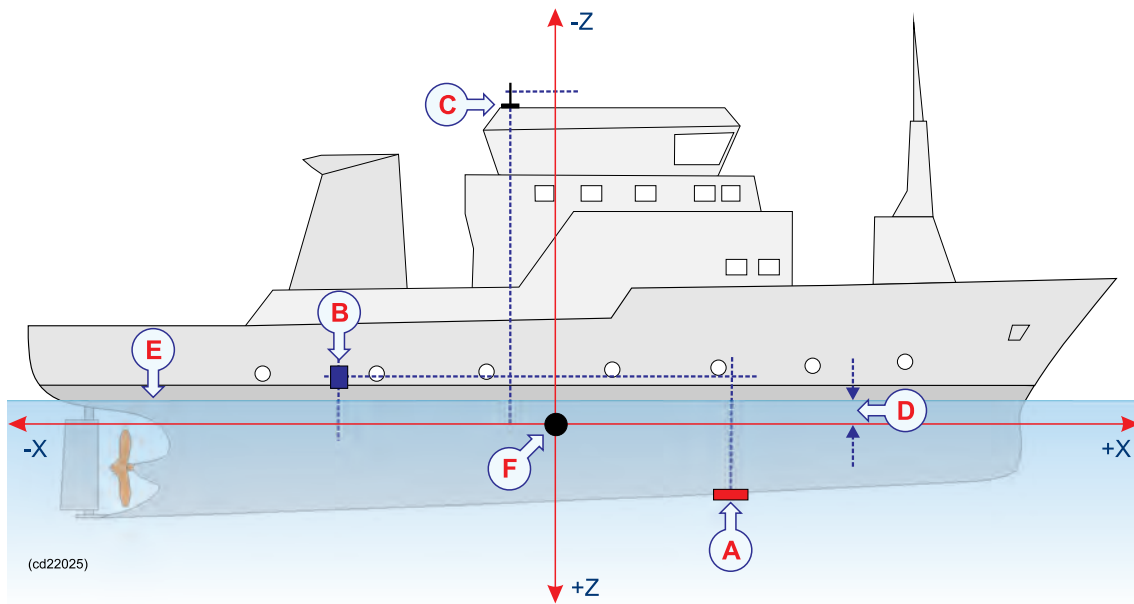

- A Transducer (+Z, +X)
- B Motion sensor (-X, -Z)
- C GPS antenna (-Z, -X)
- D Draft (-Z)
- E Waterline (-Z)
- F Reference point

Timing

Topics

- *Introduction* on page 498
- *Internal clock* on page 498
- *Time stamping* on page 499
- *Time difference PU-ZDA and PU-POS indications* on page 500

Introduction

Time synchronization between the echo sounder, the motion sensors and the positioning system is vital in order to achieve the best possible accuracy. The requirement for time synchronization accuracy is better than 5 ms for attitude, with roll being the most critical parameter. For the positioning, the required timing accuracy depends upon required position accuracy and the vessel's speed.

Example: With a vessel speed of 10 knots or 5 m/s, 100 ms timing accuracy is required for 0.5 m position accuracy.

Internal clock

An internal clock in the PU is used to time stamp all time critical data. It is a software clock with 1 millisecond resolution, and it is synchronized to an internal hardware counter. An interrupt is generated in the PU at each ping as a reference for the time of ping, and the clock is read at the reception of external sensor data. The internal clock is stable and jitter free, excepting a long-term drift of the hardware counter (typically a few seconds per 24 hours), and possible 1-2 millisecond jumps due to the internal counter not operating at exactly 1 kHz.

The software clock may be synchronized to an external 1PPS (one pulse per second) signal. This signal is normally available from a GPS receiver, and this is the preferred method to synchronize the echo sounder to an external clock. At the reception of a 1PPS pulse the millisecond field of the internal clock is set to zero. If it was larger than 200 ms, the second is incremented (with a possible incrementation of time and date if required). Note that this method of synchronization implies that loss of a few 1PPS pulses has no significance. However, spurious noise recognized as 1PPS pulses will offset the clock forward, 1 second for every spurious signal accepted.

The internal clock's time and date is adjustable to that given by an external clock, the positioning system or the operator station. However, this is only possible if the system is not logging data. Adjustment of the internal clock during data logging is not allowed as it would cause loss of synchronization between depth and attitude data.

If an external clock is connected on a serial line the input data is time stamped and logged as any other external sensor data. This allows a continuous estimation of any drifts between the two clocks. The setting of the internal clock will be to the time and

date from the source, including milliseconds as available. Note that the GGA positioning datagram does not contain any date entry. Setting from the operator station allows a manual setting of the clock.

Time stamping

For each datagram of attitudes (roll, pitch, heave and possibly heading), a time stamp is generated at the reception of the first byte of the datagram. As the attitude data may be delayed due to processing time in the motion sensor, an adjustable time delay may be applied. The attitude data are applied to the acquired ranges and beam angles to derive xyz coordinates of the soundings after bottom detection.

The only significant uncertainty in the time synchronization of attitude and depths will thus be due to possible variations in the time delay or a wrong estimation of it. However, with most motion sensors the risk of errors are small. The manufacturer's estimate of delay should be used, and a possible prediction facility in the sensor should not be used. As the attitude data may be logged as a continuous time record, it is possible to post process the data to determine and correct for any error in applied time delay.

As for the attitude data, a time stamp is generated at the reception of the first byte of each position datagram, and an adjustable time delay may be applied to this time stamp. If the real variation in this time delay is sufficiently small with respect to the position accuracy and vessel speed, the internal time stamp will give sufficiently accurate time synchronization. Time delay must of course be determined to a sufficient accuracy which is done by comparing data from survey lines run at different vessel speeds in the same direction up or down bottom slopes or over significantly distinctive bottom features. Any necessary correction of the applied time delay may be done in post processing.

If the variation in the time delay of the positions is too large with respect to the desired accuracy, even after position filtering during post processing, an alternative satisfactory solution will require two things: that the positioning system's own time stamp in the position datagram has a sufficient accuracy; and that the clocks of the echo sounder and the positioning system are synchronized. When post-processing, the positioning system's time stamp must be used, which is possible as both time stamps are retained in the logged data. If the positioning time stamp is not good enough, the positions will have to be filtered during post processing to diminish the effect of the variable timing. The inertia of the vessel will set the limit of accuracy achievable by such filtering.

The absolute setting of time in the echo sounder is usually not critical with respect to other sensors. It is recommended to synchronize the echo sounder to a 1PPS signal, if available. It is also recommended not to reset the echo sounder clock, except for at the start of a survey. This will ensure that any time delays remain constant during a survey. If an external clock is additionally connected and logged, this will allow a check of clock consistency during post processing, but this is usually not worth the effort.

The conclusion and recommendations are as follows:

- It is recommended to synchronize the echo sounder to a 1PPS signal if available
- The delay in the data from the motion sensor must be constant and known to within 5 ms

- If the delay in the position data is known within an accuracy commensurate with the position accuracy and vessel speed, no synchronization of clocks is required.
- If the delay in the position data is variable and cannot be filtered to a sufficient accuracy in post processing, or the positioning is required to also be accurate for realtime displays, the echo sounder and positioning system clocks must be synchronized.

The synchronization of the two clocks must be done from a common 1PPS signal (which may be contained in the positioning system). The echo sounder must be set up to use the positioning system time stamp (datagram time) to which any position time delay will be applied. The post processing system must also be set up to use the positioning system time stamp (a time delay may have to be applied to either the position or depth data).

Time difference PU-ZDA and PU-POS indications

The **Numerical** display can be set to monitor the PU-ZDA and PU-POS time differences. The colour indications used are based on the **1PPS** setting, the **Time to use** setting and the **clock source** selection. All these parameters are set in the **Installation parameter** frame.

See *Installation parameters* on page 274.

In most situations the acceptable time difference is +/- 1 sec, but with 1PPS off and time tag from the system the acceptable time difference is considerably larger.

The time delay limitations are system parameters and can not be changed by the operator.

	1PPS On	1PPS Off
D		
A	Timediff +/- 1 sec:	Timediff +/- 1 sec:
T	RED in 'FU-ZDA' field when Ext. clock	RED in 'FU-ZDA' field when Ext. clock
A	RED in 'FU-POS' field when Active pos.	RED in 'FU-POS' field when Active pos.
G	RED in 'FU-POS'* field when Operator st.	RED in 'FU-POS'* field when Operator st.
R		
A		
M		
S		
Y	Timediff +/- 1 sec:	Timediff +/- 30 sec.
S	RED in 'FU-ZDA' field when Ext. clock.	YELLOW in affected field.
T	RED in 'FU-POS' field when Active pos.	
E	RED in 'FU-POS'* field when Operator st.	Timediff +/- 600 sec.
M		RED in affected field.

* Conceptually not correct, but not able to compare with operator

Related topics

- *Numerical display* on page 68
- *Installation parameters* on page 274

Sound speed formulas

The echo sounder computes bottom depth, taking full account of the ray bending caused by the variation of sound speed in the water column. The Sound speed profile is entered manually, automatically from a sound speed profile probe, from an external computer, or by a combination of these methods.

If measured sound speed values are not available, they may be derived from tables, or, if the temperature and salinity profiles are known or estimated or calculated from a formula. While many formulae exist, the one from UNESCO Technical Paper in Marine Science, No. 44, is usually regarded as being authoritative. However, it is cumbersome and recent experiments showed that it has errors in the 1000-4000 m depth range. Therefore, a simpler formula with adequate accuracy is as follows (from Coppens, JASA March 1981, with a modified very deep water correction which follows the recent experimental data).

- For the surface:

$$c(0, T, S) = 1449.05 + T(4.57 - T(0.0521 - 0.00023T)) \\ + (1.333 - T(0.0126 - 0.00009T))(S - 35)$$

where:

- T is temperature in °C
- S is salinity in ppt
- For depths to 200 m in fresh water and 1000 m in the ocean:

$$c(Z, T, S) = c(0, T, S) + 16.5Z$$

where

- T is temperature in °C
- S is salinity in ppt
- Z is depth in km
- For depths to 2000 m in fresh water and to 11000 m in the ocean (assuming that the water is very cold at great depths):

$$c(Z, T, S) = c(0, T, S) + Z \left(16.3 + Z \left(0.22 - 0.003Z\sqrt{T+2} \right) \right)$$

where

- T is temperature in °C
- S is salinity in ppt
- Z is depth in km
- For depths greater than 5000 m, a latitude correction should be applied:

$$c(Z, T, S) = c(0, T, S) + Z' \left(16.3 + Z \left(0.22 - 0.003Z\sqrt{T+2} \right) \right)$$

where

- $Z' = Z(1 - 0.0026 \cos 2\Phi)$
- Φ is latitude in degrees
- T is temperature in °C
- S is salinity in ppt
- Z is depth in km

Implementation of absorption coefficients

Overview

The absorption coefficients in SIS may be set using three different sources:

- Salinity
- CTD profile
- Manual

In principle SIS can handle several echo sounders, each with its own source setting.

As a consequence SIS must maintain and control two different sets of profiles: One based on the currently set salinity value and one based on the CTD (Conductivity, Temperature and Depth) information received in an SSP datagram. The third alternative, Manual, results in the user entered absorption coefficient values being used immediately.

Absorption coefficients are dependent on the used frequency. All profile sets must therefore contain one absorption coefficient file for each frequency used by the multibeam echo sounders.

Today the required range of frequencies for the complete range of multibeam echo sounders are 12, 32, 60, 70, 80, 90, 95, 100, 200 and 300* kHz. (* used to calculate for 297 and 307 kHz internally in EM 3000 and EM 3002 Processing Units).

Parameter references

- *Filter and gains for EM 2040* on page 310

Related topics

- *Handling of SSP datagrams* on page 539

Salinity based absorption coefficient profiles

This type of absorption coefficient profiles is based on a depth and sound speed profile and the currently set salinity value. The depth and sound speed profiles can be obtained from two sources:

- 1 Reception of an SSP datagram of format S00 or S10 from the network. (All SSP datagrams results in the generation of an .asvp file which contains the necessary profile.)
- 2 The operator may select an ordinary SVP from **Runtime parameter**→**Sound Speed Profile**.

In both cases a set of absorption coefficient files are generated. All files in a set use the same naming convention: In case of a SSP datagram, the date and time contained in the datagram becomes first part of the file name. In case of an operator selected SVP file the original file name is used instead. Next, the currently set salinity is included together with the frequency for which the file is valid. See example sets below

Note that there is an **.asvp** file in each file set containing the depth and sound speed data used in the calculations. This file is named the same as the rest of the set of files, except that the frequency part is absent. This file is constructed based on the SSP input or the user selected SVP. In the latter case the file contains exactly the same data as the original SVP file, e.g. 'Horten20050304.asvp' and 'Horten20050304_salinity_03900.asvp' contains exactly the same data. See example below. The duplication and renaming of the original user selected **.asvp** file is done so that it is simple to retrieve a complete file set including the **.asvp** file using only the basic file name as key.

Note

The absorption coefficient file with frequency 32 kHz is actually for the 31.5 kHz system (EM 300).

Example of salinity file set based on SSP datagram:

```
20051230_183344_salinity_03900.asvp
20051230_183344_salinity_03900_12kHz.abs
20051230_183344_salinity_03900_32kHz.abs
20051230_183344_salinity_03900_60kHz.abs
20051230_183344_salinity_03900_70kHz.abs
20051230_183344_salinity_03900_80kHz.abs
20051230_183344_salinity_03900_90kHz.abs
20051230_183344_salinity_03900_95kHz.abs
20051230_183344_salinity_03900_100kHz.abs
20051230_183344_salinity_03900_200kHz.abs
20051230_183344_salinity_03900_300kHz.abs
```

Example of salinity file set based on user selected SVP called 'Horten20050304.asvp':

```
Horten20050304_salinity_03900.asvp
Horten20050304_salinity_03900_12kHz.abs
Horten20050304_salinity_03900_32kHz.abs
Horten20050304_salinity_03900_60kHz.abs
Horten20050304_salinity_03900_70kHz.abs
Horten20050304_salinity_03900_80kHz.abs
Horten20050304_salinity_03900_90kHz.abs
Horten20050304_salinity_03900_95kHz.abs
Horten20050304_salinity_03900_100kHz.abs
Horten20050304_salinity_03900_200kHz.abs
Horten20050304_salinity_03900_300kHz.abs
```

A new salinity based absorption coefficient file set is generated in the following instances:

- When a new SSP datagram for immediate use (S00 – S07) is received from the network.
- When the user selects a new SVP from the runtime parameter Sound Speed Profile interface.
- When the Source is Salinity and the salinity value is changed and no existing file set is found for the new salinity.
- When the user selects Salinity as Source and no existing file set is found for the currently set salinity value.

Parameter references

- *Sound speed for EM 2040* on page 305

Related topics

- *Handling of SSP datagrams* on page 539

CTD based absorption coefficient profiles

CTD based absorption coefficient profiles are only generated based on SSP datagrams with formats other than S00 and S10. These other datagrams may contain the absorption coefficient directly (with appropriate frequency listed) or they contain the necessary CTD data to calculate the absorption coefficient profiles for all frequencies.

- See *Handling of SSP datagrams* on page 539

Note that when the SSP datagram contains the absorption coefficient directly (datagrams S13, S23, S33, S43, S53) this datagram is valid for one frequency only. To be able to generate a full set of absorption coefficient files one SSP datagram of the same type for each used frequency must be received. The interval between the reception of individual datagrams must be max 10 sec. (currently). The internal date and time in the SSP datagrams must be the same for all in the received set.

Note again that the requirement is that one such SPP datagram must be received for each of the frequencies 12, 32, 60, 70, 80 90, 95, 100, 200 and 300 kHz.

When received by SIS, the SSP datagrams S01, S02, S03, S04, S05, S06 and S07 will result in an automatic and immediate use of the confined information. Therefore it is not necessary for the operator to make a manual selection for the associated SVP.

The name of CTD based absorption coefficient file sets is constructed in the same way as for S00/S10 based sets without the salinity part.

Example of a CTD file set, based on SSP datagrams different from S00 and S10:

```
20051230_183344.asvp
20051230_183344_12kHz.abs
20051230_183344_32kHz.abs
20051230_183344_60kHz.abs
20051230_183344_70kHz.abs
20051230_183344_80kHz.abs
20051230_183344_90kHz.abs
20051230_183344_95kHz.abs
20051230_183344_100kHz.abs
20051230_183344_200kHz.abs
20051230_183344_300kHz.abs
```

The CTD file set also contains an **.asvp** file. This file is generated (directly or calculated) based on the contents in the SSP datagrams.

Note that when selecting an SVP from the runtime parameter Sound Speed Profile interface it is regarded as a CTD file set only if the file name does not contain salinity and all frequency files are present.

In all circumstances a new salinity based file set is also generated from the selected SVP and current salinity. That is when a CTD based file set is used immediately (S01, S02, S03, S04, S05, S06, S07) selected or a corresponding file set for the currently selected salinity is also made.

Mode of operation

When the system is initialized the first time a system provided default file set is used both for the salinity based and the CTD based absorption coefficients. It is therefore important that realistic file sets are generated and selected as soon as possible when using SIS. However the current salinity and CTD based file sets will always be remembered and used e.g. after a restart.

When new file sets are generated upon reception of SSP datagrams the information about the new file set is sent to the SVP Editor. This editor may be used to modify the data contents of the file set (e.g. thinning). The operator may subsequently select the modified file set using the runtime parameter Sound Speed Profile interface.

- See *SVP Editor* on page 395

A file set that has been thinned, using the SVP editor, will contain 'thinned' in the file name, e.g.

```
20051230_183344_thinned_03900.asvp
20051230_183344_thinned_12kHz.abs
20051230_183344_thinned_32kHz.abs
20051230_183344_thinned_60kHz.abs
20051230_183344_thinned_70kHz.abs
20051230_183344_thinned_80kHz.abs
20051230_183344_thinned_90kHz.abs
20051230_183344_thinned_95kHz.abs
20051230_183344_thinned_100kHz.abs
20051230_183344_thinned_200kHz.abs
20051230_183344_thinned_300kHz.abs
```

The PUs are updated with new absorption coefficients according to the following principles:

- The depth measured by each echo sounder is received by the CCU (which handles the core functionality of the absorption coefficient system), currently every 15 sec.
- If the current selected **Source** is **Salinity** or **CTD-profile** an absorption coefficient deviation value is calculated for each frequency used by the echo sounder. This deviation value is based on the previous and current absorption coefficient for each frequency and a max range estimated from the received depth. If the found deviation for any frequency is greater than a preset limit (currently 0.2 dB) the new absorption coefficient for each frequency are sent to the PU.
- When calculating the absorption coefficients the current Source selection determines if the Salinity based file set or the CTD based file set is used.

In any case, when a new set of absorption coefficients are sent to the PU the values for each frequency used by the PUs are displayed in the runtime parameter's **Filter and Gains** frame.

Also, the currently used salinity and CTD-based absorption coefficient file sets are displayed in the runtime parameter **Sound Speed Profile** interface.

Note

Initially SIS is configured to use and store the Salinity and CTD based absorption coefficient file sets in one pre-defined directory. This can be changed by selecting a Salinity or CTD based file set from another location by using the runtime parameter 'Sound Speed Profile' interface. All new (i.e. generated) file sets of the specific type selected above (Salinity or CTD) will be stored in this new location. Thus, Salinity and CTD based file sets can be stored in different locations.

Note

When using an external removable storage media like a USB stick to carry an .asvp profile or a CTD-file set etc. the files must be copied to a local HWS directory before selecting them for usage (Runtime parameters > Sound speed). Never select a file for use directly from a removable medium.

Note

SIS will never remove any absorption coefficient file set from its storage location(s). If any clean-up/removal is performed by the operator, care must be taken not to remove the currently used Salinity or CTD based file set as listed in the display.

Note

The system provided default absorption coefficient file set, called 'default' must never be deleted or moved from its original position.

Artefacts causing errors and variations in the sea floor depth detections

Introduction

Sound waves need a compressible medium (like water) for propagation. Sudden changes in this medium (i.e. changes in the sound speed or changes in the acoustic impedance) bends or reflects the sound waves. Changes like these are present in the transition (or boundary) between water and the sea bottom, and are necessary for depth detection when using an echo sounder.

When the boundary is smeared or stretched out, the sounder may have problems determining the accurate numeric value representing the sea depth. These conditions vary with frequency.

While bedrock gives a distinct echo for most frequencies, the situation is more complicated for sedimentary seabed. E.g. Sometimes the upper part of the seabed consists of a liquid like layer, changing to more solid with depth. The boundary between this layer and water can be indistinct for sufficient registration at certain frequencies.

Low frequency sonars (like 12 kHz) can penetrate the boundary of this layer with almost no reflections, whilst higher frequencies, (say 100 kHz and above) usually give reflections sufficient for detection. The result is differences in the numerical depth readings when different frequencies are used.

The registration of the sea floor may also vary with the incidence angle of the sound beam, specially when the sounders are using different frequencies.

Sea bottom penetration

The seabed is an interface between water and earth, i.e. a transition between liquid and solid materials. Usually, on the accuracy scale to which the depths are to be measured, the interface is sufficiently clearly defined. However, in some cases this is not so, usually because the interface is not distinct enough with the top sediment being partly solid and partly water. Then the echo reflected back to the sounder is a combination of echoes both from the seabed and reflectors beneath the seabed. The echo sounder might then have problems distinguishing where the bottom really is, causing too deep and hence erroneous detections, as is not unusually observed on dual frequency single beam echo sounders.

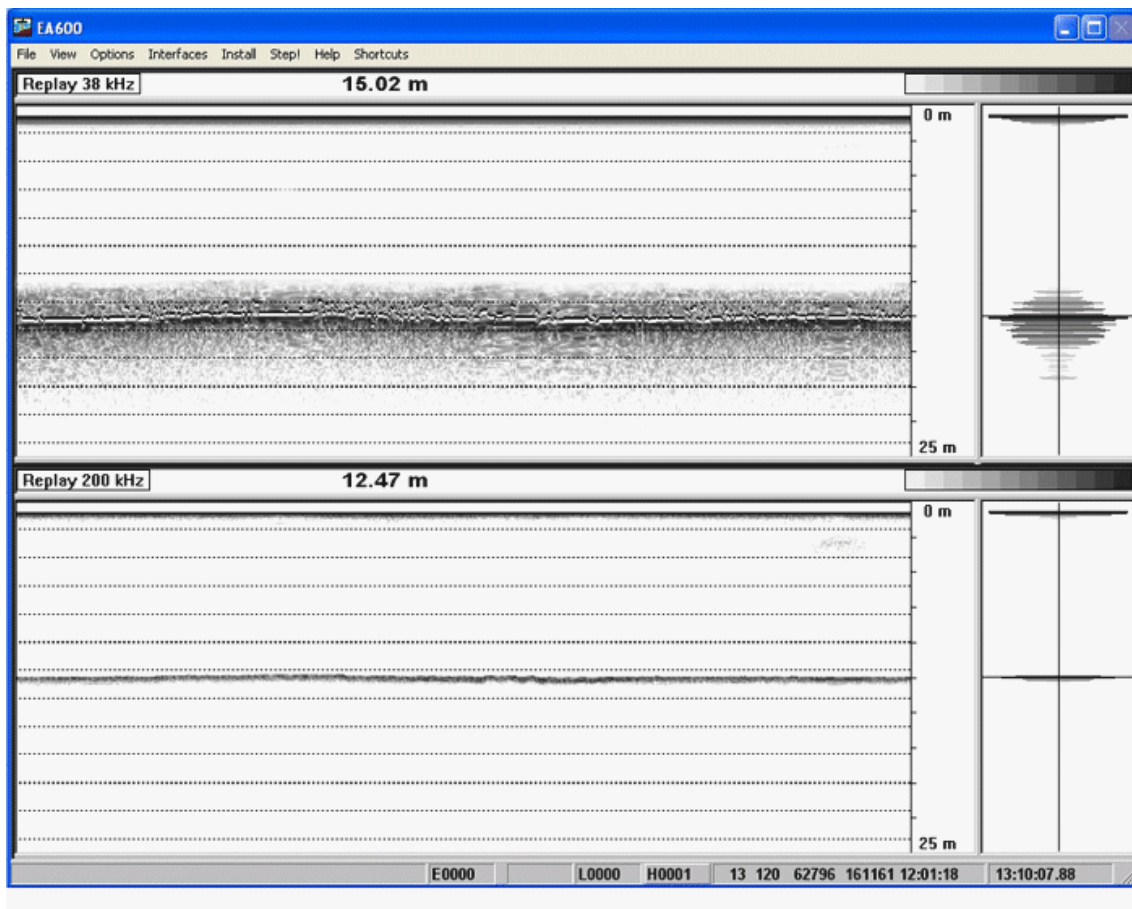
Figure 43 The echogram from an EA 600 single beam sounder

The seabed reflects a part of an incoming sound wave due to the change of the acoustic impedance, between the sea bottom and water. Most of the sound energy not going into the bottom will be reflected away as a specular reflection (i.e. as if the bottom is a mirror), but some of the energy will be scattered in other directions (hopefully with some backscattering to the echo sounder). The angular response of the seabed will depend upon its material and its smoothness (in relation to the sound wavelength). A smooth bottom (such as silt or mud) will have a narrow specular region of a few degrees with a very weak signal reflected in other directions. On a rough bottom (such as gravel), the specular peak will be quite wide and not very strong, and the reflected signal in other directions will not be much weaker. Reflected signal strength will however always decrease with increasing angle away from the specular direction.

Penetration will usually be a bigger problem on soft bottoms than on hard, due to the impedance contrast being less. Sound penetrating into the bottom may be reflected from objects such as large rocks or from layers of different material energy will just dissipate away due to bottom losses. The absorption coefficient of soft sediments has been shown experimentally to usually increase approximately linearly with frequency. Typical values at for example 12 kHz is in the range of 1-5 dB/m with the lowest values encountered when the bottom has a very high porosity (> 65%) which implies a very small particle

size (< 10 mm). Assuming that signals attenuated more than 20 dB within the seabed, will not affect the bottom detection, penetration of up to about 10 m could be possible at 12 kHz and up to 30 cm at 300 kHz.

When there is a problem with penetration, it will mainly affect the centre of the swath. In the outer parts of the swath the penetration range may be of the same order as for the centre, but the depth is lessened due to the incidence angle. In the specular region, usually at or very close to the vertical, the degree of penetration might not be problematic due to the strong specular reflection, but this might not be consistent over a large survey area. It might also be noted that when the sub-bottom of fine particles, penetration and hence too deep detections may happen all over the swath, fairly independent of beam pointing angle, although probably more often the erroneous detections will be concentrated to the centre.

The bottom detection process is aimed at avoiding false detections and only providing correct ones. However, when the bottom is such that the echoes received from the sub-bottom are stronger than those from the seabed surface, too deep detections may invariably occur. Usually this will mostly only happen on fairly smooth bottoms, which could be handled in post-processing by filtering, but unfortunately only by removal of any fine bottom features or object from the data. If this is not acceptable, the only possible alternative in an area where penetration is problematic, is to see whether any parts of the swath are less affected by others, and to only use data from these parts in the processing. The disadvantage of this procedure is of course the unavoidable large penalty in extra surveying time required

The absorption coefficient equation

The mean absorption coefficient of the water column is used in the gain setting in the receiver.

The absorption coefficient is important in determining the correct backscattering strength of the seabed used in the seabed imaging. Setting a correct value is therefore always recommended if the backscatter data are to be used, especially if the results are to be compared with those from other areas. The absorption coefficient α is given by the following equation:

$$\alpha = \frac{A_1 f_1 f^2}{f^2 + f_1^2} + \frac{A_2 P_2 f_2 f^2}{f^2 + f_2^2} + A_3 P_3 f^2$$

where

$$A_1 = \frac{8.86 \times 10^{(0.78pH-5)}}{c}$$

$$A_2 = \frac{21.44S(1 + 0.025T)}{c}$$

$$A_3 = 4.937 \times 10^{-4} - T(2.59 \times 10^{-5} - T(9.11 \times 10^{-7} - 1.5 \times 10^{-8} \times T)),$$

$$T \leq 20^\circ C$$

$$A_3 = 3.964 \times 10^{-4} - T(1.146 \times 10^{-5} - T(1.45 \times 10^{-7} - 6.5 \times 10^{-10} \times T)),$$

$$T \geq 20^\circ C$$

$$P_2 = 1 - Z(0.137 - 0.0062Z)$$

$$P_3 = 1 - Z(0.0383 - 4.9 \times 10^{-4}Z)$$

$$f_1 = 2.8 \sqrt{\frac{S}{35}} \times 10^{[4 - \frac{1245}{273+T}]}$$

$$f_2 = \frac{8.17 \times 10^{[8 - \frac{1990}{273+T}]}}{1 + 0.0018(S - 35)}$$

Here, α is given in dB/km, the sound speed c in m/s, the temperature T in $^\circ C$, the depth Z in km, the salinity S in ppt, and the frequency f in kHz. The **pH** of the ocean is in the order of 7.6-8.2.

The mean values are the mean absorption coefficient from the surface to the depth indicated, and is the value to be entered in the menu.

The absorption coefficient equation is from R. E. Francois and G. R. Garrison, "Sound absorption based on ocean measurements: Part II: Boric acid contribution and equation for total absorption," J. of Acoust. Soc. Am. 72(6), Dec. 1982, p 1886.

Projections

Scope

This section gives in-depth information on the Projection component. The purpose with the section is to describe how to program a projection and how a projection can be defined using the projection library.

Programming a projection

On the Installation DVD there is a directory called **UserSrc**. This directory contains a template for programming your own projections. On a Windows system use **usersrc.dsp** and program the projection in Microsoft Studio.

On a Windows PC the output is a dynamic link library, **userProj.dll**. Copy this file to the location where SIS is installed and replace the existing file.

You create your own projection in the file **userProj.cpp**. Follow the example in the file:

- 1 Create the routines you want to use. You have to define three routines, one for initialization of the projection, one for the projection and one for the inverse projection. It is important that the parameters are correct, see the example.
- 2 Edit the routine **InitUserProjection**. In the switch statement add a number and call your initialization routine. The number is important. You must choose a number larger than 1000 as SIS is already using the numbers below 1000. Each projection must have a unique number.
- 3 Edit the routine **ForwardProjection**. In the switch statement call your forward projection.
- 4 Edit the routine **InverseProjection**. In the switch statement call your inverse projection.
- 5 Compile and install the shared library.
- 6 Start SIS. Open the **Survey templates** window and find the tab where you define the projection. Then choose **Create new projection** and this program starts.
- 7 Choose **New...** and give the new projection a proper name.
- 8 Choose the projection type to be **User defined**. The number you enter must be the same as the one you just programmed.

You have now created your own projection.

Note

If you later reinstall SIS, this projection will be lost. You have to save the shared library file and install it after you install or upgrade SIS.

Using PROJ.4

You can also define a projection using the projection library PROJ.4. A 7-parameter datum transformation is already available in SIS.

The following text file defines a PROJ.4 projection:

```
<MyProjection>
ellps=WGS84
proj=utm
zone=32
units=cm
```

The parameter `ellps` must be defined, and `units=cm` must be used.

To add a 7-parameter datum transformation, the setup is like this:

```
<MyProjection>
ellps_from=Bessel
rotXrad=0.0000001
rotYrad=0.0000002
rotZrad=0.0000003
dXm=150.0
dYm=160.0
dZm=170.0
scale=0.9998
ellps=WGS84
proj=utm
zone=32
units=cm
```

Note that `rotXrad`, `rotYrad` and `rotZrad` are expressed in radians, and that `dXm`, `dYm` and `dZm` are expressed in meters. The primary ellipsoid is defined after `ellps_from` and the secondary ellipsoid will be defined by `ellps`.

The `to` and `from` definition of the ellipsoids are the names of the ellipsoids found in the list of ellipsoids. You see this list when you define the projection.

The transformation parameters themselves must be entered by the operator.

The operator must save this setup in a text file. He can then define a PROJ.4 projection as described above. In the text field where he types the PROJ.4 projection, type something like this:

```
+init=/mydir/somefile.txt:my_projection
```

This means that the projection is named `my_projection` and is defined in the file `\mydir\somefile.txt`.

For PROJ.4 details see `C:\Program Files\Kongsberg Maritime\SIS\doc`.

Geoid

If high accuracy antenna heights (e.g. RTK GPS or other high accuracy position systems) are extracted, predefined geoid models can be used to obtain the distance from the sea floor to your vertical reference plane (e.g. Mean Sea Surface).

The figure below shows the various distances used in the calculating the depth to the seafloor relative to the vertical reference.

Figure 44 Computation principles

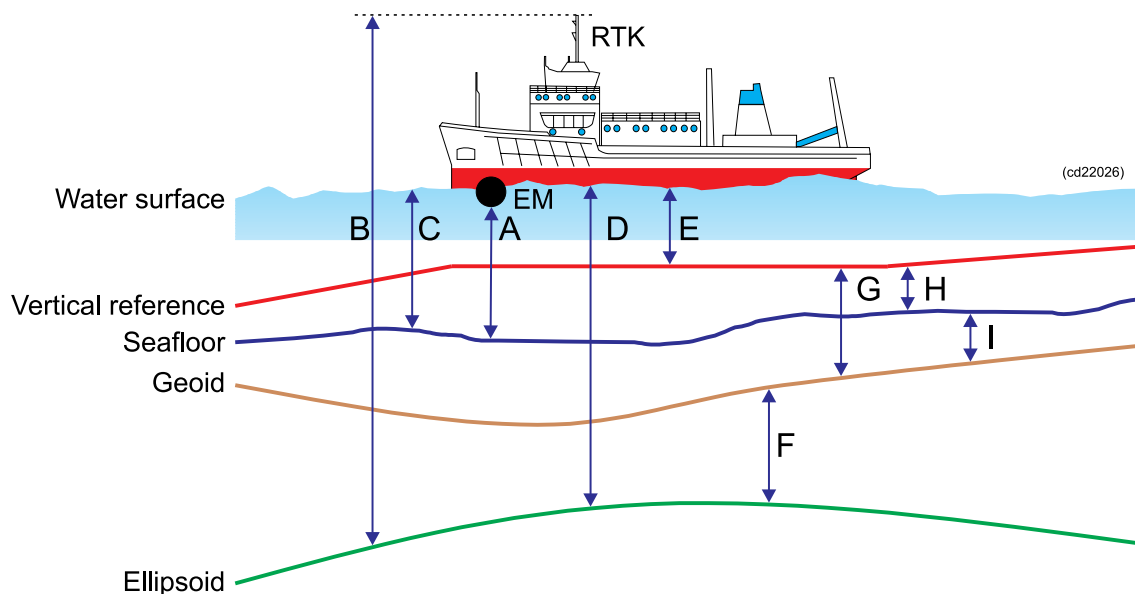

A Distance from the echo sounder to the sea floor

B Distance from the antenna to the ellipsoid

C Motion corrected distance (depth) from water surface to sea floor

The measured distance from the echo sounder to the sea floor is corrected for transducer offset and motion (heading, roll, pitch and heave) to obtain the distance from the water surface to the sea floor.

Because the heave sensor only reacts to fast changes, the water surface is in reality defined by the 0-level of the heave sensor.

D Motion corrected distance (height) from water surface to ellipsoid

The position system gives the distance from the antenna to the ellipsoid **B**. This distance is corrected for antenna offset and motion to give **D**, which is the distance from the sea surface to the ellipsoid

Note that both the corrected echo sounder depth **C** and the GPS based height above the ellipsoid **D** is now referred to the same vertical level, the sea surface.

E Distance from the sea surface to the vertical reference (tide)

The tide **E** is computed as $E = D - F - G$.

F Distance from the ellipsoid to the geoid (geoid undulation), positive if the geoid is above the ellipsoid.

This value is given by the geoid model.

G Distance from the geoid to the vertical reference, positive if the vertical reference is above the geoid.

This value is given by the geoid model.

H is the distance from the vertical reference to the sea floor and can be computed as $H = C - E$

I is the distance from the sea floor to the geoid and is computed as $I = G - H$

The geoid file

The geoid file **geoidmodel.geoid** must be stored together with the background data. See *Survey parameters* on page 263.

The next figure shows the layout of the geoid file. This layout is chosen to fit to rivers where the geoid undulation and vertical reference is known at cross profiles along the river (the vertical lines are the riverbanks). It is possible to define several “rivers” in one file thus allowing general areas to be defined.

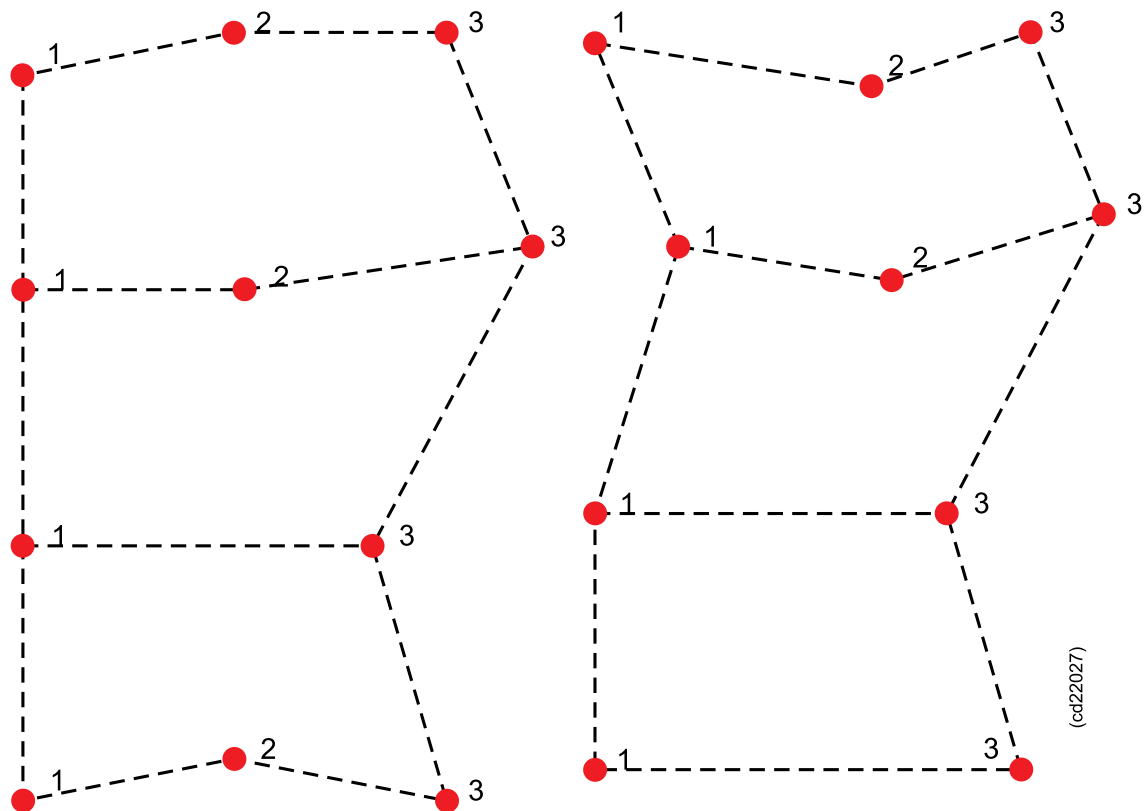

The file format is as follows:

- 1 latitude(degrees) longitude(degrees) F(meters) G(meters)
- 2 latitude(degrees) longitude(degrees) F(meters) G(meters)
- 3 latitude(degrees) longitude(degrees) F(meters) G(meters)

where **F** is distance from the ellipsoid to the geoid and **G** is distance from the geoid to the vertical reference.

The line starting with 2 is optional. The cross profile may be defined using two or three points, the first point with id 1 and the last point id 3. If there is a middle point, it has the id 2. Latitude and longitude are positive north of the Equator and east of Greenwich, negative on the other side.

An area is defined between two cross profiles. A model (river) must always have at least two cross profiles. Several models (rivers) in the same file must be separated by an empty line.

The geoid undulation F and the vertical reference G is interpolated using straight lines between cross profiles.

Tide

Tide input to SIS can be of two types: Real time tide or predicted tide.

Realtime tide

Realtime tide is sent to SIS as discrete tide datagrams using a serial link or by the network using UDP port 4001. The format of the tide datagram is as follows:

```
$ATIDE,20040512073406,1.74*00
```

The header is always \$ATIDE. Next comes the time YYYYMMDDhhmmss, and then the tide in meters.

The checksum is currently not used, but must be present.

Note

The tide is added to the depths.

The tide input using a serial line is set up in **Tools**→**External sensors**. See *External sensors* on page 371

Note

*The file **realtime.tide** will be created every time SIS is restarted.*

Predicted tide

A tide file with the name **predictedtide.tide** can be stored together with the background data for the survey, see *Survey parameters* on page 263.

The format is like this:

```
(Tide)
20040512073655 1.74
20040512073755 3.42
20040512073855 5.00
20040512073955 6.43
20040512074055 7.66
20040512074155 8.66
20040512074255 9.39
20040512074355 9.85
20040512074455 10.00
20040512074555 9.85
20040512074655 9.40
20040512074755 8.67
20040512074855 7.67
20040512074955 6.44
20040512075055 5.01
20040512075155 3.43
20040512075255 1.75
20040512075355 0.02
20040512075455 -1.72
20040512075555 -3.40
20040512075655 -4.98
20040512075755 -6.41
20040512075855 -7.65
```



```
20040512075955 -8.65  
20040512080055 -9.39  
20040512080155 -9.84  
20040512080255 -10.00  
20040512080355 -9.85  
20040512080455 -9.41  
20040512080555 -8.67
```

The first line is a header enclosed in parenthesis. The first word must be **Tide**.

Next comes the tide data. The time format is `YYYYMMDDhhmms` and the tide is in meters.

Note that the tide is **ADDED** to the depths.

Javad and Trimble details

You have to start the necessary modules to enable logging from a Javad or Trimble GPS receiver. Each module is described in sub-sections, after the following manual start-up procedures.

Note

The “(space)” remark indicates space key in the start-up commands; the letters are not a part of the commands.

Fill in the constituent data file or port number between the brackets <...>.

Mean Sea level module

```
sisMSL -d "C:\Program Files\Kongsberg Maritime\SIS\ bin" -i  
9044 -o 9041
```

Real time tide module

```
sisTide -f<constituent data> F tide5.dat -i 1 -p(space)  
9041 -p 4001
```

Here the Mean Sea level module is set up to receives GGA messages from the Javad receiver and the Real time tide module sends data to the gpsraw module logging data from the Javad receiver.

Javad GPS receiver

- RStoUDP -com <port number>,19200,8,0,1 -udpin(space) 9049
-udpout localhost,9050 -bin
- gpsraw -p 1 -t JAVAD -i 9050 -u 9049 -c 9041 -e(space)
4002 -n 4002 -g 9044

Trimble GPS receiver

- RStoUDP -com <port number>,19200,8,0,1 -udpin(space) 9038
-udpout localhost,9039 -bin
- gpsraw -p 2 -t TR4000SSE -i 9039 -u 9038 -c 9041(space)
-e 4002 -n 4002 -g 9033

Raw GPS data logging module

The raw GPS data logging module enables the user to log raw GPS measurements from a high quality GPS receiver, thus enabling the user to post process the data using any available tool, for example TerraPos from Terratec AS.

At the moment, two different GPS receivers are supported, Javad and Trimble 4000 series (tested with Trimble 4000 SSE).

Starting the programme with the option -h (i.e. `gpsraw -h`) gives the following output, which should be self explanatory:

```
gpsraw $Revision: 1.4 $
Usage gpsraw [options]

-p <1-3>                Set positioning system number
-t <gps receiver type> (JAVAD or TR4000SSE)
-i <portnum>           Reads data from this port [in]
-c <portnum>           Control port [in]
-e <portnum>           Port for error messages [out]
-u <portnum>           Port for messages to gps receiver [out]
-g <portnum>           Port to receive GGA NMEA messages [out]
-n <portnum>           Port to receive all NMEA messages [out]
-d                     Show debug messages
-v                     Show version and exit
-h                     Show this help
```

This programme reads raw gps data from one UDP port, interprets and logs the data to a file, extracts NMEA messages which may be distributed to other programs. It may control the GPS receiver by writing control datagrams to the gps receiver. It reads control datagrams which may start or stop logging to file, or set fixed height (if supported by the receiver).

NMEA messages may be distributed to multiple ports, by repeating the options -g and/or -n.

For output ports the port may be given as port, name:port or ip:port. A control port (-c) and an inport (-i) are required options.

The control datagrams that are understood are:

<code>\$KSSIS,102,dirname,ON</code>	Start logging in given directory
<code>\$KSSIS,102,dirname,OFF</code>	Stop logging
<code>\$KSSIS,103,ON</code>	Set fixed height
<code>\$KSSIS,103,OFF</code>	Reset fixed height
<code>\$KSSIS,105,23.45</code>	Geoidal separation in meters
<code>\$ATIDE,20051225123022,2.45</code>	Time and tide value [meters]
<code><Installation datagram></code>	To get antenna height

The error messages which may be returned to the port given by -e have the form:

- `$KSSIS,104, ; message text which may be long...`

Mean Sea level module

The mean sea level module calculates the Mean Sea Level (in many places almost the same as Geoid) from a set of input files and interpolates accordingly to a position received as a GGA message on an input (UDP) port. It sends the MSL value in the given position to those who need it, in particular the raw GPS logging module, which needs it for calculating antennae height when too few satellites are visible.

The programme is started from a command file or from a terminal window and using the -h option gives the following information:

```
Usage sisMSL <options>
```

Where options are:

-h	Prints this help
-d <directory>	Where to search for data files (required)
-p <pattern>	Pattern used in search. Default: .grid
-i <portnum>	Where to receive GGA messages from (required)
-o <portnum>	Where to send geoid separation (Can be repeated. At least one is required)
-D	Prints debug information

This programme reads geoid separation files from a directory and interpolates in the files from a position received on a port with NMEA GGA messages. The ports can be given as either hostnum:port, ip:port or just port.

Real time tide module

The real time tide module calculates the tide from a set of input files. One normally called **tide5.dat**, can be generated, and the other contains the constituents for the nearest harbour. The programme can calculate the tide using phase and amplitude offsets as well as correcting for the current air pressure (given that the correct tide is known). The internal clock of the computer must be correct for this real time module to work correctly.

The programme has also the capability to make a prediction file, using other options.

A typical usage for the programme, with typical options which gives the tide corrected to LAT are:

```
sisTide -f stavanger.xdo -F tide5.dat -p 4001 -s 1.1(space)
-t 12 -l 0.05 -z 0.65 -i 10
```

By using the -h option the following help message is returned:

```
use sisTide [options]
```

-h	Show this message and return
-v	Show version and return
-c	Show copyright notice
-q	Show file formats and return
-f <filename>	Read constituent data from this file

- F <filename> Read Foreman data from this file
- i <number> Interval for sending or calculating data [min] (default 60)

The following two options are for sending real time predictions:

- p <portnum> Send to port (default localhost:4001)

The following two options are for generating predictions for a date:

- D<YYYYMMDD> Start date for predictions
- d <number of days> Number of days to give predictions for (default 1)

Note

If -D is given, -p ignored.

Options for changing the calculations:

- a Amplitude factor (default 1.0)
Multiply the result with this factor.
- t Secondary harbour time correction [min] (default 0)
Added to time before calculating tide (delaying tide)
- l Level correction [m] default 0.0
Add to tide after calculations
- z Use this level (positive number) [m] for Z0 (default 0.0)
Add to tide after calculations

Note

Z0 value from file is never used.

Constituent (-f) and Foreman (-F) files must always be given.

Note

Predicted tides are always referring to UTC (GMT). This can be changed using -t option (-t60 gives MET).

Environment variable TZ must be correctly set to get correct real time predictions. (e.g. TZ = MET - 1METDST).

Predicted tides are calculated relative to mean sea level unless Z0 (-z) and/or level corrections (-l) are given.

The results are negated so ADDING the results to measured depths should give tide-corrected depths.

RStoUDP

The RStoUDP module makes it possible to control/receive data on UDP from equipment attached to RS232 serial lines:

```
Usage RStoUDP -com  
<prt>, <baud>, <databit>, <parity>, <stopbit> -udpin <port>  
-udport<ip, port> -udpout[1-4]<ip, port> -ts -distudp  
-log <logfile> -confsock <port> -bin <buf size> -t  
<timeout (usec)>
```

Legal values for parity is 0=none, 1=odd and 2=even, where:

- -com (Comm port to use)
- -udpout (Port nr. for incoming data)
- -ts (Add timestamp to ASCII data)
- -udpout[n] (Additional output sockets)
- -distudp (Distribute incoming udp data to all udp out sockets)
- -confsock (Socket for incoming config messages)
- -bin <size> (Binary mode and buffer size)
- -t (Timeout value when reading binary data)

Example: RStoUDP -com 4,9600,8,0,1 -udpout(space) localhost, 2020 -log log.dat

Dead reckoning and position jump filter

The Dead reckoning calculation and Position jump filter functionality described here, are used to avoid temporary stops and position jumps when updating the ship symbol in the Geographical view.

Missing positions and unstable position input will typically occur when the positioning system antenna(s) is obstructed by e.g. bridges or other structures.

Both Dead reckoning and Position Jump filter can be enabled/disabled independently using the **Tools**→**Customs**→**Set parameters**→**Positions menu**.

Note

*Position jump filtering is also performed in another context. It is used for gridding purposes and the objective is to avoid erroneous data being used in the gridding operation and subsequently displayed in the gridded data in the Geographical View. This operation is automatic, but the parameters to use can be changed using the **Tools**→**Customs**→**Set parameters**→**Positions menu**.*

Dead Reckoning

If the position input stops for more than 0.5 second, SIS will predict all subsequent missing positions for a set period of time, currently 30 sec. The prediction is based on the last two good positions which are used to calculate the speed. In addition the last good heading is used in the calculations to determine the direction.

When the set prediction period expires, or if a new good position is received, the prediction stops.

Note

If the position update frequency is 1 Hz, the current setting will imply that a predicted position is generated 0.5 seconds (approximately) after a real position, giving an update frequency of the boat symbol of 2 Hz.

Position jumps

A position filter is used to remove excessive jumps in position. If a jump is detected, a predicted position is calculated and used instead. The criteria for a position jump is that the speed exceeds a set limit, currently 30 m/sec. Also, a position jump is assumed if the heading calculated from the last two positions exceeds a ± 20 degree corridor scaled according to the position quality.

Note

The position jump filter only removes one erroneous position (the first) if several consecutive erroneous positions are received.

The predicted positions (from Dead Reckoning calculations or Position jump filter) are never logged. They are used to update the boat symbol in the Geographical View. The predicted position datagrams are not distributed to external recipients that have subscribed to position datagrams.

*Missing position input will be indicated in the **PU sensor status display** and in the **PU status lamp** in **Main menu bar**. A message is also logged in the **Message service** when positions are missing.*

Related topics

- *Request datagrams from an echo sounder on page 559*
- *PU sensor status view on page 86*
- *Main toolbar on page 33*
- *Message service view on page 69*

Checking of legal beam pointing angles

Checking of legal runtime sonar head beam pointing angles is performed when changing the sonar head installation angles. This function is only relevant for the EM 2040, EM 2040C, EM 3000 and EM 3002 echo sounders.

When changing the sonar head installation angles this will affect the validity of the sonar head beam pointing angles set in the **Runtime parameters**→**Sounder Main** frame. The new installation angles will modify the allowed maximum and minimum settings for the sonar head beam pointing angles and the currently used values may therefore, as a result, be outside the legal range. The test aims to inform the operator about this situation so that corrective action may be taken. The figure below shows the relevant angles for a dual head system (e.g. a dual EM 3002).

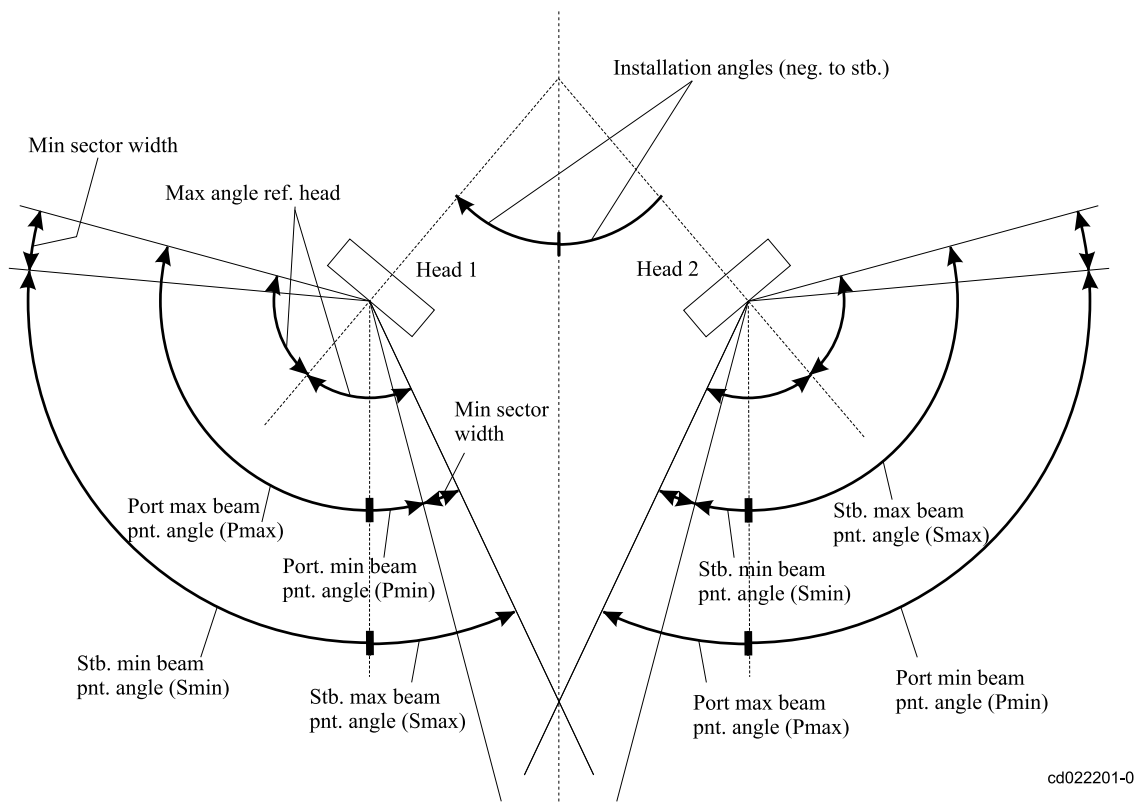

When calculating and setting these angles the following rules apply:

- All angles are referenced to the vertical downward axis, i.e. 0 deg. is downward
- The installation angles are positive to port and negative to the starboard (applies to both heads).
- The port beam pointing angle is positive to the port whereas the starboard beam pointing angle is positive to the starboard (applies to both heads).
- The maximum allowed beam pointing angle relative to the head is dependent on the type of sounder and in some cases on the serial number (i.e. EM 3002 shallow and deep water heads). This information is used when performing calculations to determine maximum and minimum allowed beam pointing angles relative to the vertical downward axis.

The algorithm to determine the minimum and maximum allowed beam pointing angles for EM 3002 / EM 2040 / EM 2040C echo sounders are as follows:

The **EM3002 minimum sector width** is used to make sure that the port and starboard beams on a head do not “close”. This **Minimum sector width** is set to 10 degrees. The **EM3002 max angle ref. head** is 60 deg or 65 deg, depending on deep or shallow head type.

HEAD 1

The maximum legal beam pointing angles:

Sonar head 1 port max angle (Pmax) =
EM3002 max angle ref. head
+ 'Inst. ang. sonar head 1'
Sonar head 1 starboard max angle (Smax) =
EM3002 max angle ref. head
- 'Inst. ang. sonar head 1'

The minimum legal beam pointing angles:

Sonar head 1 port min angle (Pmin) =
'Sonar head 1 port max angle (Pmax)'
- (2*EM3002 max angle ref. head)
+ EM3002 minimum sector width
Sonar head 1 starboard min angle (Smin) =
'Sonar head 1 starboard max angle'
- (2*EM3002 max angle ref. head)
+ EM3002 minimum sector width

HEAD2

Same calculations as for HEAD 1. Remember installation angle for HEAD 2 is normally negative (i.e. pointing to starboard).

Datagram and file formats

This chapter provides a description of some of the datagram and file formats used by SIS.

Topics

- *TPU – Error estimate logging format* on page 530
- *Export formats* on page 531
- *Depth under keel output format* on page 534
- *Depth profile output* on page 535
- *Terrain referenced position* on page 536
- *Survey plan file format* on page 538
- *Handling of SSP datagrams* on page 539
- *Sound speed profile formats* on page 544
- *External datagram (C+T) format* on page 550
- *ATH data format* on page 551
- *SRH data format* on page 555
- *TerraPOS data format* on page 556
- *Changing behaviour of notification messages* on page 558
- *Request datagrams from an echo sounder* on page 559
- *Request datagrams – manual set-up* on page 561
- *Data distribution* on page 567
- *Remote datagrams* on page 568
- *Notification of SIS pinging and logging activity* on page 570
- *Difference in log file formats* on page 573
- *Barometer input* on page 574
- *K-Sync interface* on page 575
- *Port allocation* on page 576

TPU – Error estimate logging format

This option is only available when importing raw data into SIS. There are two possible formats:

- basic format: the simple format which outputs: Beam number, horizontal error and vertical error.
- extended format: a more complete format which outputs: Beam number, latitude[degrees], longitude[degrees], north[cm], east[cm], depth, horizontal error[cm] and vertical error[cm]

At the top of the file, a header is written, explaining the format of the file: The TPU files are placed on the same disk as the grids in the folder sisdata/surveyName/sf and are named lineNumber_date_time.tpe (0010_20060907_130302.tpe).

TPU logging is enabled by selection from the **SIS parameters Logging** option which are located under **Tools**→**Custom...**→**Set parameters**→**Logging**.

See *Logging* on page 341.

Export formats

When data is exported from SIS, different export formats can be chosen.

The ASCII output contains an entry describing the file contents. Note that positions are in projection coordinates and in centimetres. Depths are also in centimetres. Time is in milliseconds since epoch 0 UTC 1 January 1970.

The binary output also contains this information. The following is an example code of how to read the binary files:

```
//h+////////////////////////////////////
/*!
// \file readSISBinaryOutput
//
// \brief Example of how to read the binary output
// from SIS
// \author Terje Pedersen
//
// \date 10-OCT-2003
//
// \par Copyright:
//
// Copyright by Kongsberg Simrad
//
//
// \par Revision History:
//
// \par 01 10-OCT-2003 tp
//
// Original Version.
//
//
*/
//h-////////////////////////////////////
#include <stdio.h>
#include <stdlib.h>
#include <time.h>
#include <string.h>

//! Little endian cell data
#ifdef WIN32
typedef __int64 i64;
#else
typedef long long i64;
#endif
typedef struct {
    int m_lEastCm, m_lNorthCm;
    int m_iDepthCm;
    int m_iFlag;
    int m_iResidualCm;
}SLittleEPointRec, *SLittleEPointPnt;

typedef struct {
    int m_lEastCm, m_lNorthCm;
    i64 m_lDate;// millisec. since epoch
    int m_iPingno, m_iBeamno;
    int m_iDepthCm;
```

```

    int m_iFlag;
    int m_iResidualCm;
}SLittleEPointExtraRec, *SLittleEPointExtraPnt;

//f+////////////////////////////////////
//
/*!
// \brief Convert milliseconds since epoch to date
//
// \param mtime, milliseconds since epoch
// \param year, month, day, hour, min, sec, millisec
//
// \return void
//
// \author Terje Pedersen
//
// \date 10-OCT-2003
//
// \note
*/
//f-////////////////////////////////////

/void convertMsecToDate(i64 mtime, int *year,
    int *month, int *day, int *hour, int *min,
    int *sec, int *msec)
{
    i64 t;
    time_t nt;
    struct tm stm, *ptm;
    if (year == NULL || month == NULL || day == NULL ||
        hour == NULL || min == NULL || sec == NULL ||
        msec == NULL) return;
    t = mtime/1000;
    *msec = (int)(mtime - (t*1000));
    nt = (time_t)t;
    ptm = localtime(&nt);
    if (ptm == NULL) return;
    memcpy(&stm,ptm,sizeof(stm));
    *year = stm.tm_year+1900;
    *month = stm.tm_mon+1;
    *day = stm.tm_mday;
    *hour = stm.tm_hour;
    *min = stm.tm_min;
    *sec = stm.tm_min;
}

//f+////////////////////////////////////
//
/*!
// \brief Read the binary output from SIS
//
// \param type, what type of file to read
// \param filename, name of file to read
//
// \return void
//
// \author Terje Pedersen
//

```

```

// \date 10-OCT-2003
//
// \note
*/
//f-////////////////////////////////////

int readSISBinaryOutput(int type, char *filename)
{
    FILE *fd;
    SLittleEPointRec le;
    SLittleEPointExtraRec lex;

    if (type < 1 || type > 2) return -1;
    //printf("%d %d\n", sizeof(le), sizeof(lex));

    fd = fopen(filename, "rb");
    if (fd == NULL){
        fprintf(stderr, "Cannot open file: %s\n", filename);
        return -1;
    }

    if (type == 1){// Little endian point data
        while(fread(&le, 1, sizeof(le), fd)){
            printf("East %d cm, North %d cm, Depth %d cm, Flag %d,
                Residual %d cm\n", le.m_lEastCm, le.m_lNorthCm,
                le.m_iDepthCm, le.m_iFlag, le.m_iResidualCm);    }//while
        }//if type == 1
    if (type == 2){// Little endian point data with extras
        int year, month, day, hour, min, sec, msec;
        while(fread(&lex, 1, sizeof(lex), fd)){
            convertMsecToDate(lex.m_lDate, &year, &month, &day,
                &hour, &min, &sec, &msec);
            printf("East %d cm, North %d cm,
                Date %I64d %04d%02d%02d %02d%02d%02d.%d,
                Ping no. %d, Beam no. %d, Depth %d cm, Flag %d,
                Residual %d cm\n", lex.m_lEastCm, lex.m_lNorthCm,
                lex.m_lDate, year, month, day, hour, min, sec, msec,
                lex.m_iPingno, lex.m_iBeamno, lex.m_iDepthCm,
                lex.m_iFlag, lex.m_iResidualCm);
        }//while
    }//if type == 2
    return 0;
}

int main(int argc, char*argv[])
{
    if (argc != 3){
        printf("\n\nUsage: %s <type> <filename>\n\n", argv[0]);
        printf("Types:\n!");
        printf("1: little endian point data without time.\n");
        printf("2: little endian point data with time.\n");
        printf("Long must be 8 bytes, it is %d bytes\n", sizeof(i64));
        printf("\n\n");
    }//if

    return readSISBinaryOutput(atoi(argv[1]), argv[2]);
}

```

Depth under keel output format

NMEA 0183 (V 3.01) DPT – Depth Below Transducer

`$KBDPT,x.x,x.x,x.x*hh<CR><LF>`

Maximum range in use is always 12000.0.

The **Centre depth output** is always sent as a NMEA DPT datagram on UDP to port number 4310.

Depth profile output

The datagram is sent from the HWS.

This datagram is sent to IP:port using UDP, defined in Datagram subscriptions, token NMEA_MDM.

Transmit depth profiles format

These are the internal datagrams:

```
$KSSIS,x-x,c-c\n\r
```

There is only one NMEA-style datagram. The datagram identifier is SIS, and the manufacturer is always KS. The first number is an integer, which identifies what comes in the rest of the datagram. Since c-c is a string of characters, and since comma and \n\r are reserved characters in this format, it is understood that any text enclosed in double quotes are treated as one block of text which then may contain commas and \n\r.

30	ModelNo,SerialNo, date(YYYYMMDD), time(millisecond. since midnight), NoRealtimeDepths,SprojCoord*	Datagram sent from the HandleDDS to the GeoView containing all the XYZ points.
----	--	---

As an example the datagram from the time; 08:12:51, January 5. 2010, can be like this:

```
$KSSIS,30,710, 345, 20100105,29571234, 45,...\n\r
```

where ... are binary data of the type SprojCoord:

```
struct SProjCoord
{
    int m_iEastCm,          //!< East in projection
                           coordinates (centimetres)
    m_iNorthCm,           //!< North in projection
                           coordinates (centimetres)
    m_iDepthCm,           //!< Depth in centimetres.
    m_iTideCorrCm,        //!< Depth Tide corrected.
    m_iVRefCm,            //!< Depth ref. vref. using
                           geoid model.
    m_iGeoidCm,           //!< Seafloor to geoid
    m_iEllipsoidCm;       //!< Seafloor to ellipsoid.
};
```

Note

m_iDepthCm will always be valid. If not the other information are available, they will not be valid.

Terrain referenced position

Range and bearing to objects: This will be sent from the HWS to IP:port using UDP, where IP:port is set in SIS parameters. SIS shall use NMEA sentences BWR and WPL for this purpose.

There are two scenarios:

- 1 The operator selects a target relative to the current ship position, where the ship position is the reference point.

See *The vessel coordinate system* on page 496 for reference point definition.

The output shall then be range and bearing from the current ship position to the selected target:

```
$PKBWR,hhmmss.ss,1111.111111,a,YYYYY.YYYYYY,a,x.x,T,x.x,
M,x.x,N,c--c,a*hh<CR><LF>
```

Where the letters specifies:

hhmmss.ss,	hh is for hours, mm is for minutes and ss.ss is for seconds.
1111.1111,a,	The time of observation The waypoint latitude, N/S
YYYYY.YYYYYY,a,	Waypoint longitude, E/W
x.x,T,	Bearing, degrees TRUE
x.x,M,	Bearing, degrees Magnetic
x.x,N,	Distance, nautical miles
c- -c,	Waypoint ID
a,	Mode indicator: A = Autonomous mode D = Differential mode E = Estimated (dead reckoning) mode M = Manual input mode S = Simulator mode N = Data not valid

```
$--WPL,1111.111111,a,YYYYY.YYYYYY,a,c - - c*hh<CR><LF>
```

Where the letters specifies:

1111.1111,a,	The waypoint latitude, N/S
YYYYY.YYYYYY,a,	Waypoint longitude, E/W
c- -c,	Waypoint ID

The operator selects a target in the geographical display. When he decides to send this target to IP:port using UDP, the current ship's position is found. The time in this datagram is the time from that position. Bearing is only calculated for true bearing, T; magnetic bearing is NOT calculated and the value is left blank. The waypoint identifier is also left blank, and the mode indicator (a) is always M.

- 2 The operator selects two points and the output shall be range and bearing from the first point to the second point.

```
$PKWPL,1111.111111,a,YYYYY.YYYYYY,a,c--c*hh<CR><LF>
$PKBWR,hhmmss.ss,1111.111111,a,YYYYY.YYYYYY,a,x.x,T,x.x,
M,x.x,N,c--c,a*hh<CR><LF>
```

First a WPL message is sent. This message contains the position of the first waypoint. The identifier field is now set to "WP1". Then a BWR message is sent. The position is the second waypoint, and the identifier is "WP1", the identifier

of the waypoint in the first message. The distance is from the first to the second waypoint, and the bearing is from the first to the second waypoint. Only true bearing is calculated.

Survey plan file format

The survey plan file can be stored as a binary file with extension ***.sisplan** or as ASCII files in the existing Neptune format.

The first line gives information about the Latitude/Longitude format used in the file. There are four different options:

DEG – Degrees, decimal degrees

MIN – Degrees, minutes and decimal minutes

SEC – Degrees, minutes and seconds

PROJECTION – Projection coordinates

The next line is a comment or text that follows the job.

The following is an example of the format to define a planned line:

```
_LINE <Line Name> <Line Number> <Time of creation>  
<Flag><N><E><N><E>'<Comment>
```

The time of creation is the HWS time given in the following format:

```
YYYYMMDDhhmms
```

where:

- **YYYY** – The Year
- **MM** – The month of the year
- **DD** – The day of the month
- **hh** – The hour of the day
- **mm** – The minutes in the hour
- **ss** – The second of the minute

The polygon has a similar format, except:

- Starts with **_POLYGON**
- The name is always polygon
- The line number is always 0
- The flag is always 0
- It is not possible to attach information to a polygon

Handling of SSP datagrams

Topics

- *Overview* on page 539
- *Usage* on page 541
- *Reception handling of SSP format input* on page 542

Overview

The SSP datagram format is used for input of depth or pressure profiles containing:

- Sound speed (m/s)
- Temperature (°C)
- Salinity (parts per thousand)
- Absorption coefficient

SSP datagrams are sent to the HWS on port 4001.

The SSP format is a generic format and the actual type of information conveyed is defined by an identifier. Currently the following are defined:

Identifier	Input data	Data to be used	Comment
S00	D,c	D,c	Same as S10, but used immediately
S01	D,c,T,S	D,c,a(D,T,S,L)	Same as S12, but used immediately
S02	D,T,S	D,c(D,T,S,L), a(D,T,S,L)	Same as S22, but used immediately
S03	D,T,C	D,c(D,T,C,L), a(D,T,S,L)	Same as S32, but used immediately
S04	P,T,S	D(P,T,S,L), c(P,T,S,L), a(P,T,S,L)	Same as S42, but used immediately
S05	P,T,C	D(P,T,C,L), c(P,T,C,L), a(P,T,C,L)	Same as S52, but used immediately
S06	D,c,a	D,c,a	Same as S11, but used immediately

Identifier	Input data	Data to be used	Comment
S07	P,c,T,C	D(P,T,C,L), a(P,T,C,L,c) ^[1]	Same as S14, but used immediately
S10	D,c	D,c	
S11	D,c,a	D,c,a	
S12	D,c,T,S	D,c,a(D,T,S,L)	
S13	D,c,a,f	D,c,a	Frequency dependent
S14	P,c,T,C	D(P,T,C,L), a(P,T,C,L,c) ^[1]	
S20	D,T,S	D,c(D,T,S,L)c	
S21	D,T,S,a	D,c(D,T,S,L),a	
S22	D,T,S	D,c(D,T,S,L),a(D,T,S,L)	
S23	D,T,S,a,f	D,c(D,T,S,L),a	Frequency dependent
S30	D,T,C	D,c(D,T,C,L)	
S31	D,T,C,a	D,c(D,T,C,L),a	
S32	D,T,C	D,c(D,T,C,L),a(D,T,C,L)	
S33	D,T,C,a,f	D,c(D,T,C,L),ai	Frequency dependent
S40	P,T,S	D(P,T,S,L),c(P,T,S,L)	
S41	P,T,S,a	D(P,T,S,L),c(P,T,S,L),a	
S42	P,T,S	D(P,T,S,L),c(P,T,S,L),a(P,T,S,L)	
S43	P,T,S,a,f	D(P,T,S,L),c(P,T,S,L),a	Frequency dependent
S50	P,T,C	D(P,T,C,L),c(P,T,C,L)	
S51	P,T,C,a	D(P,T,C,L),c(P,T,C,L),a	
S52	P,T,C	D(P,T,C,L),c(P,T,C,L),a(P,T,C,L)	
S53	P,T,C,a,f	D(P,T,C,L),c(P,T,C,L),a	Frequency dependent

Legend

a Absorption coefficient

c Sound speed

C Conductivity

D Depth

f frequency

-
1. The datagram contains measured sound speed as well as parameters required to compute the sound speed. The measured sound speed is used in the sound velocity profile and to compute the absorption coefficient.

P Pressure

L Latitude (always present)

S Salinity

T Temperature

The notation **a(D,T,S,L)** means that the absorption coefficient (i.e. *a*) is calculated from depth, temperature, salinity and latitude.

Usage

The use of absorption coefficients from SSP datagrams are available for all types of echo sounders.

Upon reception of SSP datagrams, SIS will always generate a sound velocity profile file (.asvp), either directly (e.g. if S00, S11 is received) or by performing the necessary calculations to determine the sound speed (*c*) from the supplied data.

An absorption coefficient profile file (.abs), based on the supplied data, will also be generated for all frequencies used by the echo sounders.

There is a special case for the SSP datagrams S13, S23, S33, S43 and S53. These datagrams has been extended to also include a frequency for which the contained data is valid. This makes it possible to specifically set all absorption coefficients to be used for the relevant frequency.

Note

When one of these particular datagrams are used SIS will require one datagram for each of the frequencies used by the echo sounders (i.e. 12, 31.5, 60, 70, 80, 90, 95, 100, 200, 250, 300, 350 and 400 kHz). They must be sent within 10 sec. of each other and have the same acquisition date and time.

A subset of the SSP datagrams, specifically S00, S01, S02, S03, S04, S05, S06 and S07, will be used immediately. That is, the corresponding sound velocity profile and absorption coefficients will be sent to the PU(s). The Runtime parameters frame, if displayed, will be updated with the new file set information.

When SSP datagrams are received by SIS, the **SVP Editor** will always be informed.

If the SVP Editor is not running, it will be started automatically if enabled by the **Tools**→**Custom**→**Set Parameters**→**Sound speed menu**.

You may edit the .asvp and .abs files and store the edited files using the SVP editor. You can use these files by selecting the .asvp file, i.e. sound profile, from the **Runtime parameters**→**Sound Speed**.

Parameter references

- *Sound speed for EM 2040* on page 305

Related topics

- *SVP Editor* on page 395

Reception handling of SSP format input

Up until SIS version 3.8 it has been assumed that the SSP format input (i.e. Sxx format type datagrams) has been correct when received. Only a minimum of error checks have been performed before use. From SIS 3.8 the following basic problem situations in the received SSP datagram will be reported:

- 1 Illegal no. of samples (legal 1-1000)
- 2 Illegal time of acquisition (legal 000000-235959)
- 3 Illegal date of acquisition (legal 1-31)
- 4 Illegal month of acquisition (legal 1-12)
- 5 Illegal year of acquisition (legal 0000-9999)
- 6 Number of set samples don't correspond with found no. of samples
- 7 End of datagram not found
- 8 Illegal sound speed value (legal 1400-1700 m/sec)
- 9 Illegal depth value (legal 0-12000.0m)
- 10 Decreasing depth value
- 11 Multiple similar depth values.
- 12 Sound speed profile is not extended to 12000m (accepts depths in the range 11900m-12000.0m as legal extension)
- 13 Depth values less than 1cm apart (i.e. 3 or more decimals resolution is not legal)
- 14 Profile contains too many samples. Max 570 samples for EM 120, EM 300, EM 1002, EM 2000, EM 3000. Max 1000 otherwise.

If a vessel uses a combination of echo sounders allowing both 570 and 1000 samples, e.g. an EM 120 and an EM 710, the smallest number restricts the max sample limit (i.e. 570 in this case). The reason is that the same profile is used on all active (started) echo sounders.

- 15 Unknown error.

In addition an incoming SSP datagram (format type Sxx) will be rejected in the SIS network input function, **with no operator warning**, if the basic datagram format is violated, i.e. when it is impossible to recognise a legal datagram, e.g.:

- Message format is not correct, e.g. missing '\$' in header start, alignment problems in header, etc.
- Undefined format type (identifier) i.e. where Sxx is not a defined SSP format (e.g s00 or S99).

Generally, if a received SSP datagram is correct it will be accepted by SIS and handled according to its type. S0x format types (identifiers) will always be used immediately implying that all started echo sounders (PUs) will be updated with the new profile and the new absorption coefficients will be applied when required. All non S0x format types will be prepared for manual selection using the **Runtime parameters**→**Sound Speed** frame.

However, if the received SSP datagram is recognized, but contains errors the use of the datagram will be stopped at different stages depending on the seriousness:

- If the error is in the range 1–7 (see above) this is a serious problem and the processing is always aborted. The indicated problem must be corrected and the datagram re-sent to SIS.
- If the error is in the range 8–15 the problem is less serious and it may be corrected by using the SVPEditor that will be automatically started if enabled. Alternatively the problem may be corrected outside the SIS context and the datagram re-sent to SIS.

Regarding the use of the SVPEditor when receiving an SSP datagram the following should be noted.

- S0x format types intended for immediate use and containing no errors will never start the SVPEditor. If an error is detected the SVPEditor will be started only when enabled.
- All other format types will start the SVP editor when received if the startup is enabled.

Related topics

- *SVP Editor* on page 395

Sound speed profile formats

Internally SIS uses sound speed data in the ASVP format only. The ASVP format is an ASCII format described in this section.

All sound speed profiles must be converted to the ASVP format before they can be applied by SIS. Several methods for converting a sound speed file into the ASVP format exists.

In addition, several sound speed probes can be directly interfaces and instantaneously applied by SIS. The supported formats are described in this section.

Finally, SIS also reads the ACTD format. This applies to special profile containing water density in addition to the sound speed. It is used in ROV operations where the scaling factor is automatically calculated.

Topics

- *ASVP format* on page 544
- *Supported sound velocity probes* on page 546
- *ACTD format* on page 548

Related operational procedures

- *How to collect the sound velocity profile* on page 141
- *How to convert your sound velocity profile to SIS format* on page 143
- *How to modify and load a sound speed profile into SIS* on page 151

Parameter references

- *Sound speed for EM 2040* on page 305

Related topics

- *External sensors* on page 371
- *SVP Editor* on page 395

ASVP format

The standard sound speed profile used in SIS has the file extension **.asvp** (ASCII sound velocity profile). The file layout is as follows:

Header (the first line enclosed in brackets)

```
( SoundVelocity Version Id Time Lat Long Radii Valid_from  
Valid_to Src Hist No_val )
```

Note

Note the space character after the leading bracket and before the closing bracket.

SoundVelocity:	An identification of the file type (sound speed profile file)
Version:	The file format version number (usually 1.00)
Id:	A possible identifier
Time:	The time of creation for this file (YYYYMMDDhhmm or YYYYMMDDhhmmss)
Lat:	The latitude of the profile location (decimal degree)
Long:	The longitude of the profile generation (decimal degree)
Radii:	The radii around the lat/long position for which this profile is valid (m).
Valid from:	The time interval in the year from which this profile is valid (YYYYMMDDhhmm)
Valid to:	The time interval in the year to which this profile is valid (YYYYMMDDhhmm)
Src:	The source of the profile (e.g. probe name, database name, editors name etc.)
Hist:	The history of modifications on the profile (P=probe, E=edited, M=merged, N=new)
No val:	The number of values that are used in the profile

Data

Depth:	The water depth (m)
SounVelocity:	The sound speed (m/s) at the corresponding depth

ASVP file format example

```
( SoundVelocity 1.00 12 200605290813
 22.3452678 66.4483298 4500 200605290813
200605301210 SVP-16 PE 8 )
0.1 1483.6
5.0 1484.2
7.0 1485.3
12.0 1488.1
20.0 1485.7
25.0 1484.0
40.0 1483.8
12000.0 1509.6
```

Data restrictions

- Legacy echo sounders (i.e. EM 120, EM 300, EM 1002, EM 2000 and EM 3000,) can handle maximum 570 data entry points.
- The new generation of echo sounders (i.e. EM 122, EM 302, EM 710, ME70/BO and EM 3002,) can handle maximum 1000 data entry points.

Error checking

The sound speed profile selected from **Runtime parameters**→**Sound speed** is checked for possible errors before it is being used. If applicable, an error message is reported to the user for the following errors:

- Sound velocity out of range (legal range [1400-1700] m/s)
- Depth out of range legal range [0-12000] m
- Depth inconsistency, i.e. depth decreasing

- Depth inconsistency, i.e. multiple similar depths
- Depths not extended to 12000 m
- Unknown format in file
- Missing or unknown creation time
- Unknown conversion error

Even though SIS supports several types of sound speed profiles, the checking will be performed to the file after it has been converted to **.asvp** format.

Before the profile is accepted by SIS all reported errors must be corrected for, e.g. using the SVP Editor.

Supported sound velocity probes

SIS supports the following sound velocity probes directly:

- AML SV
- AML SV&T
- AML SV&P
- AML Micro SV
- AML Micro SV&T
- AML Micro SV&P
- Valeport Mini SVS

The probe is selected from the **External sensors** located in the **Tools** menu.

AML SV

The AML Micro SV output message is an ASCII character string that includes the sound velocity (in m/s) and a carriage return/line feed message termination pair.

```
"SV\r\n" // example: "1484.92\r\n"
```

AML SV&T

The AML SV&T output message is a space delimited ASCII character string that includes the temperature (in degrees C), sound velocity (in m/s), and a carriage return/line feed message termination pair.

```
"T SV\r\n" // example: "11.739 1484.92\r\n"
```

AML SV&P

The AML SV&P output message is a space delimited ASCII character string that includes the pressure (in dbar), sound velocity (in m/s), and a carriage return/line feed message termination pair.

```
"P SV\r\n" // example: "000.40 1484.92\r\n"
```

AML Micro SV

The AML Micro SV output message is an ASCII character string that includes the sound velocity (in m/s) and a carriage return/line feed message termination pair.

```
"SV\r\n" // example: "1484.92 \r\n"
```

AML Micro SV&T

The AML Micro SV&T output message is a space delimited ASCII character string that includes an (optional) date (MM/DD/YY), an (optional) time (HH:MM:SS:hundreths of seconds), the sound velocity (in m/s), temperature (in degrees C), and a carriage return/line feed message termination pair.

```
"DATE TIME SV T\r\n" // example: "05/14/03 14:23:06:02  
1484.92 11.739\r\n"
```

SIS will accept the message with or without the date and with or without the time.

AML Micro SV&P

The AML Micro SV&P output message is a space delimited ASCII character string that includes an (optional) date (MM/DD/YY), an (optional) time (HH:MM:SS:hundreths of seconds), pressure (in dbar), the sound velocity (in m/s), and a carriage return/line feed message termination pair.

```
"DATE TIME P SV\r\n" // example: "05/14/03 14:23:06:02  
000.40 1484.92\r\n"
```

SIS will accept the message with or without the date and with or without the time.

For all AML probes

SSV (surface sound velocity) is a 6 digit number which gives the sound velocity in m/s (for example 1500.03).

T (temperature) is a five digit signed number which gives temperature in degrees celcius using the following format: ± 00.000 . No sign is displayed for positive temperatures.

P (pressure) is a five digit signed number which gives the pressure in decibars using the following format ± 00.000 (or ± 000.00) depending on the pressure.

Valeport Mini SVS

The Valeport Mini SVS probe supports a large number of output formats.

SIS only supports three of these formats; the default format and two alternate formats.

-

Valeport standard (default) format

The default output message is an ASCII character string that includes a leading space followed by the sound velocity (in mm/s), and a carriage return/line feed message termination pair.

```
" SV\r\n" // example: " 148492\r\n"
```

•

Valeport Alternate Format #1

The alternate #1 output message is an ASCII character string that includes a leading space followed by the sound velocity (in m/s), and a carriage return/line feed message termination pair.

```
" SV\r\n" // example: " 1484.921\r\n"
```

•

Valeport Alternate Format #2

The alternate #2 output message is an ASCII character string that includes a leading space followed by the sound velocity (in m/s), and a carriage return/line feed message termination pair.

```
" SV\r\n" // example: " 1484.92\r\n"
```

ACTD format

This is a special profile containing water density in addition to the sound speed. It is used in ROV operations where the scaling factor is automatically calculated.

The file extension is **.actd** (Ascii density profile).

The error checking as described in *Sound speed profile formats* on page 544 also applies to the **.actd** format.

Note

*The **ctd** term in the file extension is not entirely accurate in this case. It is used as a general term to indicate that the file contains additional parameters to depth and sound speed.*

The file layout is as follows:

Header (the first line enclosed in brackets)

```
( ACTD Version Id Time Lat Long Radii  
Valid_from Valid_to Src Hist No_val )
```

Note

Notice the space character after the leading bracket and before the closing bracket.

ACTD:	An identification of the file type.
Version:	The file format version number (usually 1.0)
Id:	A possible identifier
Time:	The time of creation of this file, (YYYYMMDDhhmmss) seconds (i.e. 'ss') are optional
Lat:	The latitude of the profile location (decimal degree).
Long:	The longitude of the profile generation (decimal degree).

Radii:	The radii around the lat/long position for which this profile is valid (m)
Valid from:	The time interval in the year from which this profile is valid (YYYYMMDDhhmm)
Valid to:	The time interval in the year to which this profile is valid (YYYYMMDDhhmm)
Src:	The source of the profile (e.g. probe name, database name, editor's name etc.).
Hist:	The history of modifications on the profile (P=probe, E=edited, M=merged, N=new)
No val:	The number of values (i.e. sample sets) that are used in the profile

Note

All elements in the header must be represented. The 'Time', 'Lat', 'Long' and 'No val' must always have real valid values.

Data

This is the file body which consist of **No val** number of sample sets, each sample set is placed on a separate line

Depth:	The water depth (m)
SoundVelocity:	The sound speed (m/s) at the corresponding depth
Density:	The water density (kg/l) at corresponding depth

An example:

```
( ACTD 1.00 12 20060529081355 22.3452678 66.4483298
  4500 200605290813 200605301210 SVP-16 PE 7 )
0.20 1496.18 0.890
6.10 1491.51 0.890
41.97 1474.97 1.02
165.77 1480.02 1.14
271.28 1481.57 1.15
427.28 1484.42 1.15
12000.00 1669.00 1.19
```

Note

This header will eventually (in later releases) get the same format as the .asvp file type.h

Note

The same restrictions regarding number of data entry points in the profile applies to the .actd file type as to the .asvp file type.

External datagram (C+T) format

If **Ext. datagrams (C+T)** is selected UDP is used.

The format of the external UDP datagram used with the **Ext. datagrams (C+T)** sensor selection is as follows:

```
$KSSIS,80,c.c,t.t,\n\r
```

where

- **\$KSSIS** specifies that this is a Kongsberg proprietary datagram format
- **80** is the datagram number indicating that this is an external sound speed sample
- **c.c** is the sound speed at transducer represented as an ASCII text string e.g. 1460.95
- **t.t** is the temperature at transducer represented as an ASCII text string e.g. 19.25
- **\n\r** is the closing sequence (linefeed, carriage return)

This datagram must be sent to port 4001 on the HWS computer.

ATH data format

The **Applanix POSMV True Heave (ATH)** data format is defined below. Note that the output is binary data.

Header:

```
// Time and distance fields (part of header), see [1] 4.2.3

// POSMV Header, see [1] 4.2.3
groupStart[4]; $GRP
groupID;      Group Member
byteCount;    Group Dependent
time1;        seconds
time2;        seconds
distanceTag;  meters
timeTypes;
distanceType;
```

Data:

GROUP 1 - Vehicle navigation solution, see [1] 4.3.1.1

```
latitude;      (-90,90]  degrees
longitude;     (-180,180] degrees
altitude;      (,)      meters
northVelocity; (,)      meters/second
eastVelocity;  (,)      meters/second
downVelocity;  (,)      meters/second
vehicleRoll;   (-180,180] degrees
vehiclePitch;  (-90,90]   degrees
vehicleHeading; [0,360)   degrees
vehicleWanderAngle; (-180,180] degrees
vehicleTrackAngle; [0,360)   degrees
vehicleSpeed;  [0, )      meters/second
vehAngRateLong; Vehicle angular rate about
                longitudinal axis (,)degrees/second
vehAngRateTrans; Vehicle angular rate about
                transverse axis (,)degrees/second
vehAngRateDown; Vehicle angular rate about down
                axis - (,) degrees/second
vehAccLong;    Vehicle longitudinal acceleration
                - (,) meters/second^2
vehAccTrans;   Vehicle transverse acceleration
                - (,) meters/second^2
vehAccDown;    Vehicle down acceleration
                - (,) meters/second^2
alignmentStatus;
```

GROUP 102 - Sensor 1 position, Velocity, Attitude, Heave & Dynamics, see [2] 3.3.2.2

```
latitude;      (-90,90]  degrees
longitude;     (-180,180] degrees
altitude;      (,)      meters
alongTrackVelocity; (,)    meters/second
acrossTrackVelocity; (,)    meters/second
downTrackVelocity; (,)    meters/second
```

roll; (-180,180] degrees
pitch; (-90,90] degrees
heading; (-180,180] degrees
wanderAngle; (-180,180] degrees
heave; (,) meters
angRateLong; angular rate about longitudinal axis - (,) degrees/second
angRateTrans; angular rate about transverse axis - (,) degrees/second
angRateDown; angular rate about down axis - (,) degrees/second
accLong; longitudinal acceleration - (,) meters/second²
accTrans; transvers acceleration - (,) meters/second²
accDown; down acceleration - (,) meters/second²

GROUP 103 - Sensor 2 Position, Velocity, Attitude, Heave & Dynamics, see [2]

3.3.2.3

latitude; (-90,90] degrees
longitude; (-180,180] degrees
altitude; (,) meters
alongTrackVelocity; (,) meters/second
acrossTrackVelocity; (,) meters/second
downTrackVelocity; (,) meters/second
roll; (-180,180] degrees
pitch; (-90,90] degrees
heading; (-180,180] degrees
wanderAngle; (-180,180] degrees
heave; (,) meters
angRateLong; angular rate about longitudinal axis - (,) degrees/second
angRateTrans; angular rate about transverse axis - (,) degrees/second
angRateDown; angular rate about down axis - (,) degrees/second
accLong; longitudinal acceleration - (,) meters/second²
accTrans; transvers acceleration - (,) meters/second²
accDown; down acceleration - (,) meters/second²

GROUP 104 - Sensor 1 Position, Velocity and Attitude Performance Metrics, see [2]

3.3.2.4

NPositionRMS; [0,) meters
EPositionRMS; [0,) meters
DPositionRMS; [0,) meters
alongTrackVelocityRMSError; [0,) meters/second
acrossTrackVelocityRMSError; [0,) meters/second
downTrackVelocityRMSError; [0,) meters/second
rollRMSError; [0,) degrees
pitchRMSError; [0,) degrees
headingRMSError; [0,) degrees

GROUP 105 - Sensor 2 Position, Velocity and Attitude Performance Metrics, see [2] 3.3.2.5

```
NPositionRMS;    [0,) meters
EPositionRMS;    [0,) meters
DPositionRMS;    [0,) meters
alongTrackVelocityRMSError; [0,) meters/second
acrossTrackVelocityRMSError; [0,) meters/second
downTrackVelocityRMSError;  [0,) meters/second
rollRMSError;    [0,) degrees
pitchRMSError;   [0,) degrees
headingRMSError; [0,) degrees
```

GROUP 110 - MV General Status & FDIR, see [2] 3.3.2.6

```
SPOSMVGroup110;  User logged in - bit 0 : set
                  reserved      - bit 1 to 31
```

GROUP 111 - Heave & True Heave Data, see [2] 3.3.2.7

```
trueHeave;
trueHeaveRMS;
status;
heave;
heaveRMS;
heaveTime1;
heaveTime2;
rejectedIMUDataCount;
outOfRangeIMUDataCount;
```

GROUP 112 - NMEA Strings, see [2] 3.3.2.8

```
variableGroupByteCount; [0,)
NMEAStrings;
```

GROUP 113 - Heave & True Heave Performance Metrics, see [2] 3.3.2.9

```
heaveTime1;      seconds
qualityControl1;
qualityControl2;
qualityControl3;
status;          Quality Control 1 Valid - bit 0 : set
                  Quality Control 2 Valid - bit 1 : set
                  Quality Control 3 Valid - bit 2 : set
                  reserved - bit 3 to 31
```

Footer:**POSMV Footer, see [1] 4.2.3**

```
pad[2];          0
checksum;
groupEnd[2];     $#
```

References

- [1]: POS TNG3 Core User Control, Display, Data and Logging Port Interface Control Document, Applanix, Rev. 8
- [2]: POSMV V4 User ICD, Applanix, Rev.2.0

SRH data format

The **Seapath Real Heave (SRH)** data format is defined below. Note that the output is binary data.

```
cHeader1;      !< I.e. 0xAA
cHeader2;      !< I.e. 0xXX (0x52=Real Heave)
iEpcSec;       !< Seconds since start of epoc (19700101).
                MSB is index 0, i.e. Big Endian representation.
nFracSec;      !< 0.0001 fractions of a sec. MSB is index 0,
                i.e. Big Endian representation.
iHeave;        !< Heave in cm. Big Endian representation.
cStatus;       !<
cChecksum1;    !< MSB of checksum (Checksum is an unsigned short,
                the split is done to handle alignment probl.)
cChecksum0;    !< LSB of checksum
```

TerraPOS data format

The TerraPOS data format is defined below. Note that the output is binary data.

```

1 SfFileMainHeadRec , Main head record
1 SfPosHeadRec, Private head records
n SfPosRec, IFF position records.

//-----
// Survey format File headers
//-----

//-----
// At the start of a surveyformat file there is always a FileMainHeadRec
// This record is the same for all survey format files
//-----
noSwap;          /* Parameter to check swapping */
pid;             /* Process id (not used) */
formatVersion;  /* Fileformat version */
noHist;         /* SPARE: Number of history elements */
sizeof_myHeadRec; /* sizeof header following the main file header
sizeof_myDataRec; /* sizeof the data records in file
spare;
comment[128];

//-----
// Position data needs specified info into its head rec
// Position data head rec
//-----
firstHead;      header of first datagram
startTgmHead;   header of start datagram
sensor;
version;
active;         set if this sensor is the active one.
spare2;        align
datum;         /* The datum of the positions */

/* nytta ved makeXyz naar djup skal plasserast */
/* Faar ein initiell romslig verdi, og kan setjast vha regel */
maxDistDiff;   /* Max diff. in distance for interp. [cm] */
maxTimeDiff;   /* Max diff. in time for interp. [ms] */
sensID;        /* 0,1,2,3 */
spare3;
spare4[2];
// ref Terrapos: More info about datum
ref_frame[64];

//-----
// Position data record
//-----
// The survey format positon record is a COPY of the raw data positioning datagram.
// The only change is that the ascii data string is exchanged with a binary record
// of position extra info.

// Latitude in decimal degrees *20000000 (negative in southern hemisphere)
// Longitude in decimal degrees *10000000 (negative in western hemisphere)

// NOTE: DO NOT CHANGE THIS FORMAT!!!
// It will cause problems for modules which treats SfPosRec as an EmXPosRec.

/* telegram head */
head;          /* 16 bytes */
latitude;
longitude;
posQuality;   for Terrapos: HRMS
speed;
course;
heading;
sysID; /*Id: bit 0-2 number, bit 4 decode Sim90, bit 7 active*/
noRawBytes; /* SF: Always sizeof sfPosExtraRec */
id[2]; /* two first letters of ascii datagram,
        Added because of alignment needed */
data;        /* SF: Ascii string removed, sfPosExtraRec added instead. */

```

```
/* telegram end */  
etx;  
checksum;
```

Changing behaviour of notification messages

Notification messages are used in SIS when something is being reported or brought to the attention of the operator. Several levels of notification are available:

- Information
- Warning
- Error

All can be used with or without pop-up and sound. All notification messages results in an entry in the SISDB database, which can be viewed using the **Message Service**. See *Message service view* on page 69.

Notification messages generated in SIS are defined in a file found in the directory where SIS is installed.

The following directory and file name typically defines all messages and the behaviour in SIS as they occur:

C:\Program Files\Kongsberg Maritime\sis\bin in a file called messages_R_Sy.uni.

This file is in UNICODE and must be edited in an editor that supports UNICODE, like WordPad. You can change both the text message and the type of the message.

The header of this file describes the valid types. Each message has a type field which can be set to the operator's preferences. Simply change the type field for the messages you want and save the file. Make sure you save it as UNICODE.

Then open a terminal window in the directory where you saved this file. Issue the following command:

```
osql -Usisuser -Psimrad0 -imessages_R_Sy.uni
```

SIS will now react to the messages as described in the file.

Note

These settings may be lost when SIS is upgraded or reinstalled. If you want to make sure you always have these settings, save this file somewhere on your system. Reapply it when SIS is reinstalled.

Note

When SIS is upgraded the settings must be re-entered manually as described above. This is because SIS will use new upgraded database files, and any new content will be lost if the old saved file is reapplied.

Request datagrams from an echo sounder

When an echo sounder is registered on the network in SIS, and started, datagrams can be routed from the echo sounder to selected IP addresses on the network.

The echo sounder must have been configured and started in the normal manner. Then start the Request datagrams program: **Tools**→**Custom**→**Datagram distributions**.

Request datagrams from EM

Echosounder: EM122_888

Datagram: Position (P)

Options: All

IP:Port:

Subscribe **Unsubscribe**

Please restart SIS for changes to take effect

Datagram	IP:Port	Interval
Information	localhost:9004	All
Information	localhost:4002	All
Clock	localhost:4002	All
Depth	localhost:4002	All
Installation	localhost:9004	All
Position	localhost:16138	All
Position	localhost:9004	All
Position	localhost:9009	All
Position	localhost:4002	All
Position	HDPC:5052	All
Runtime	localhost:4002	All
XYZ88	localhost:4002	All
Height	localhost:4002	All
Watercolumn	localhost:16132	All

Exit **Help**

- 1 Select the echo sounder from the first pull-down menu
- 2 Select datagram from second pull-down menu
- 3 Select the output interval of the datagrams from the third pull-down menu
- 4 Fill out the text field IP:Port with IP address and UDP port number to send the data to
Remember the colon between the address and the port number
- 5 Press Subscribe
- 6 Repeat for all datagrams required

7 Restart SIS for the setting to take effect

When the echo sounder is started again, the requested datagram type(s) will be sent to the specified address(es) at the set interval.

To stop sending datagrams, select the datagram from the list and press **Unsubscribe**.

Note

Never try to “Unsubscribe“ the factory defined datagrams.

Sending options

The options for sending out the datagrams are as follows:

- 1 All – meaning distribution whenever a datagram is received
- 2 Interval – distribution when datagram is received and later with a specified interval (from 1 sec to 1 minute)

Note

It is the latest datagram received in an interval that will be distributed at the end of the interval (i.e. when selecting no 2 above).

Also, when the datagram arrival frequency is low and the distribution interval is short the last received datagram may be sent several times. This set-up is normally not appropriate for e.g. Position datagrams, but may serve better for Installation datagrams.

Datagram selection

The majority of the datagrams that can be selected for distribution, are datagrams generated and sent from the echo sounders.

Currently there are three datagrams that are not of this category, these are the remote datagrams R00, R10 and R12. In this case these datagrams are NOT the remote datagrams generated by an external system for the purpose of controlling SIS as described in *Remote datagrams* on page 568.

Rather, these datagrams are generated locally in SIS as a result of the operation of the pinging and logging buttons. Please see description in *Notification of SIS pinging and logging activity* on page 570

The intention is that an external system may be able to follow (i.e. shadow) the SIS pinging and logging operations.

Note

The R-datagrams must always be selected with the “All“ option to avoid multiple retransmissions of the datagrams.

Request datagrams – manual set-up

Note

*This chapter is intended for advanced users only. It is simpler to subscribe on datagrams by selecting **Tools**→**Custom**→**Datagram distribution**. See *Request datagrams from an echo sounder* on page 559.*

Overview

The subscription setup of datagrams from the DDS can be performed in two ways:

- 1 By using a provided utility (see note above) specifying the relevant echo sounder, datagram and subscriber IP address. These entries are semi permanent i.e. valid until the database is completely rebuilt.
- 2 By updating the database tables manually. These changes will be permanent. Currently this option requires that the database is completely rebuilt.

Manual update of database tables

The SIS DDS has the ability to distribute (i.e. retransmit) datagrams received from the Processing Unit (and other sources) out to external recipients. This distribution is done according to settings in the SIS database. Therefore, in order for an external recipient to subscribe to a particular datagram, the SIS database must be updated to distribute the datagram.

Note that SIS contains several DDS applications of different types. Each type is adapted to handle a specific type of Processing Unit or equipment. Currently three DDS types are of interest:

- 1 A generic multibeam type (EM 3000, EM 3002, EM 2000, EM 1002, EM 710, EM 300, EM 120)
- 2 A generic NMEA single beam type (receiving NMEA DPT or NMEA DBT, NMEA GGA, NMEA HDT or NMEA HDM)
- 3 A GPS and compass (receiving NMEA GGA, NMEA HDT or NMEA HDM)

The SIS Database

The SIS database contains several tables which defines the datagram distribution set-up in DDS. These tables can be divided into four categories:

- 1 A category with one table defining the datagrams and the distribution parameters
- 2 A category with one table defining sockets used for sending datagrams
- 3 A category with one table linking the two, i.e. defining which datagram to be sent on which socket
- 4 A category with several tables organizing datagrams and sockets according to type of DDS process

Table 'dds_datagrams_send' (category 1)

This table is used to define all datagrams which can be distributed by a DDS. Each entry (i.e. row) is identified by a datagram id ('id_datagram') which must be unique.

The **dds_datagrams_send** table normally only needs to be updated when new datagrams are defined or new DDS types are added. However, when a datagram subscription is defined it is necessary to know the correct **id_datagram** value as this value is used in other tables.

Figure 45 Relevant SIS database tables for subscription configuration

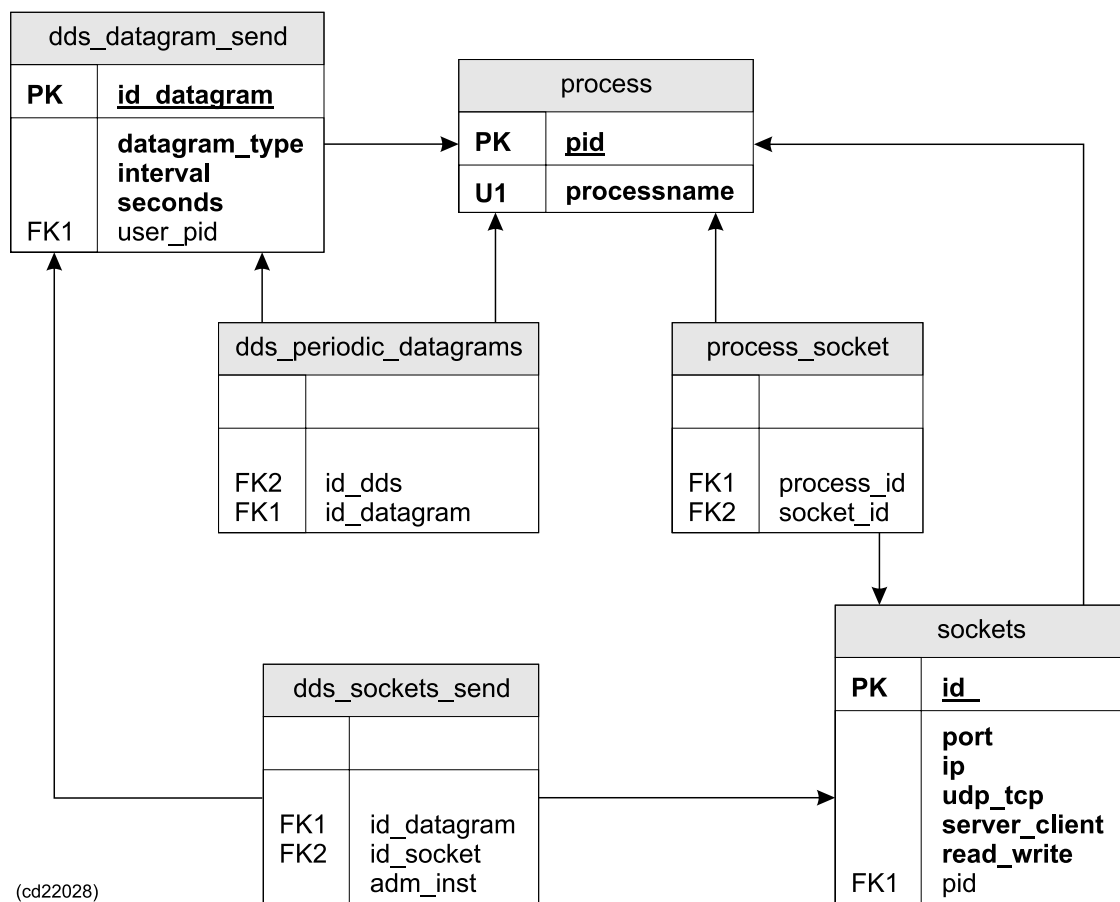

id_datagram

Note that the datagram identifiers are organized in ranges or sets, one for each type of DDS (i.e. PU or equipment type) - see **user_pid** below. The generic EM multibeam set currently has an **id_datagram** range from 36 to 302 (with some holes). NMEA singlebeam has a range from 400 to 475 and the GPS compass type has a range from 500 to 575.

datagram_type

The **datagram_type** parameter defines the type of datagram (e.g. Depth = 'D' = 68) associated with the specific datagram id. The same datagram type may be used in all ranges, if relevant, but only once in each range.

interval, seconds

These parameters are used to define how to distribute the associated datagram. The **interval** parameter may have the following values:

- 0 - Distribute signal when received
- 1 - Distribute signal repeatedly with a set interval defined by the **seconds** parameter.
- 2 - Distribute signal when received and repeat, as above
- 3 - Distribute signal only upon request (currently not implemented).

user_pid

This parameter identifies the DDS type associated with the **id_datagram** parameter. The correct **user_pid** value is found in the **process** table as the **pid** parameter (marked with bold in entries below):

- 1 DDS generic multibeam type (EM 3000, EM 3002, EM 2000, EM 1002, EM 710, EM 300, EM 120) is entry: (**10**, 'DDS_GENERIC_EM')
- 2 Generic NMEA single beam type is entry: (**14**, 'DDS_GENERIC_SINGLEBEAM_NMEA')
- 3 For GPS and compass is entry: (**13**, 'DDS_GENERIC_GPS')

The range scheme and the use of the same datagram type in several ranges allow datagrams to be handled differently for each DDS type (i.e. PU/equipment type).

Table 'dds_periodic_datagrams' (category 4)

This table defines which datagrams, (defined in **dds_parameters_send**) belong to which DDS type. Each entry (i.e. row) defines such a relation. The **dds_periodic_datagrams** table normally only needs to be updated when new datagrams are defined or new DDS types are added.

id_dds

This parameter identifies the DDS type. The correct value is found in the **process** table as the **pid** parameter (marked with bold in entries below):

- 1 DDS generic multibeam type (EM 3000, EM 3002, EM 2000, EM 1002, EM 710, EM 300, EM 120) is entry: (**10**, 'DDS_GENERIC_EM')
- 2 Generic NMEA single beam type is entry: (**14**, 'DDS_GENERIC_SINGLEBEAM_NMEA')
- 3 For GPS and compass is entry: (**13**, 'DDS_GENERIC_GPS')

id_datagram

Id of datagram from the correct range in the **dds_datagrams_send** table according to DDS type.

Table sockets (category 2)

This table defines all sockets in the SIS system including all sockets used by DDS. If a subscription is added or changed it may be necessary to define a new socket or change an existing socket. The socket will be used by DDS for sending the subscribed datagrams to the recipient.

id

Each socket in SIS must have a unique id. This is an integer number. **Before selecting an id for the socket make sure it is below 1000 and not already used** (make a search in the SISDB_v3.sql and any other SISDB_vX.sql file with a higher version than X=3).

port, ip

This is the net address for the recipient of the subscribed datagram(s).

udp_tcp

0 = UDP, 1 = TCP

The UDP protocol must always be used. This setting shall therefore be 0.

server_client

0 = server, 1 = client, 2 = unused

SIS is a server. **This setting shall therefore be 0.**

read_write

= 0 read, 1 = write, 2 = read and write

The socket is always write. **This setting shall therefore be 1.**

pid

This parameter gives an id to the recipient on the other side of the link. For the purpose of distributing datagram from the DDS to an external recipient the **pid value must be set to 76 - NOTE this value.**

Table 'process_socket' (category 4)

This table defines which sockets, (defined in 'sockets') that belong to which process. Each entry (i.e. row) defines such a relation.

The **process_socket** table needs to be updated when new datagrams are defined or new DDS types are added.

process_id

This parameter identifies the process using the socket; in this case that is a DDS type. The correct value is found in the **process** table as the **pid** parameter (marked with bold in entries below):

- 1 DDS generic multibeam type (EM 3000, EM 3002, EM 2000, EM 1002, EM 710, EM 300, EM 120) is entry: (**10**, 'DDS_GENERIC_EM')
- 2 Generic NMEA single beam type is entry: (**14**, 'DDS_GENERIC_SINGLEBEAM_NMEA')
- 3 For GPS and compass is entry: (**13**, 'DDS_GENERIC_GPS')

socket_id

Id of the socket used to distribute datagrams to the recipient. The **socket_id** is found in the **sockets** table as the **id** (see above) of the relevant socket definition.

Table 'dds_socket_send' (category 3)

The table is used to connect datagrams with sockets, i.e. it tells which datagrams (identified by 'id_datagram') that should be sent out on which socket.

This is the essential routing information necessary to be able to distribute the datagrams to the correct recipient.

In essence, all the other tables are only help tables necessary to define the datagrams and sockets (and who they belong to), whereas the routing information in **dds_socket_send** is what we really want to specify.

id_datagram

A defined datagram id belonging to a DDS type which is the same as for **id_socket** below.

id_socket

A defined socket id belonging to a DDS type which is the same as for **id_datagram** above.

When making entries in this table, care must be taken to pair only datagrams and sockets associated with the same DDS type (identified by 'process_id' in 'the 'process_socket' table and 'id_dds' in the 'dds_periodic_datagrams' table respectively).

Procedure for setting up a datagram subscription

The tables to be modified are located in the **SISDB_v3.sql** file.

- 1 Check if the datagram to be subscribed exist in **dds_datagram_send** table for the relevant DDS type. If not, define it. Remember the **id_datagram** value.
- 2 Check if the datagram exist in the **dds_periodic_datagrams** table for the correct DDS type. If not, define it.
- 3 Make a socket for the recipient, in the **sockets** table using correct IP address. Remember the **id_socket** value.

- 4 Make an entry in the **process_socket** table with the new **id_socket** value and the relevant DDS type.
- 5 Make an entry in the **dds_socket_send** table with the correct combination of **id_datagram** and **id_socket**. Note that one socket can be used for several datagrams.
- 6 The SIS database must be re-built and SIS restarted.

Important notes and restrictions

- All entries in the tables described above are currently done with reference to three DDS types. These types are regarded as templates used to instantiate database entries for new echo sounders detected on the network. Instantiation is necessary due to the fact that several echo sounders can not use the same data and the same objects (e.g. sockets.) Each echo sounder will therefore get a separate set of sockets and datagram ids, which mean that the specific values entered in the tables above, are not actually used for any echo sounder.
- However, the IP address for the recipient of a datagram is a value that can not be instantiated. This implies that the DDSes for e.g. EM 3000, EM 3002, EM 2000, EM 1002, EM 710, EM 300, EM 120 will send a datagram to the same recipient if they are detected in the same SIS system.
- **When the changes in the SIS database are performed the database must be re-built and SIS restarted.**
- The settings will be semi permanent, i.e. they will be in effect until the database is completely rebuilt.

Data distribution

The **DataDistrib** program is included with SIS. This is a Windows application that can be used to route or distribute UDP datagrams to various destinations on the local PC or to other networked PCs.

The application has a graphical user interface where you can set up distribution of data from up to 10 different sources. In a grid you set up the incoming sockets from where to listen to data and up to four different destinations for each source. It is also possible to store incoming data to a file and later replay that file. If you want to replay data, a file name is entered instead of a source port.

Make sure that you enter a Source port that is not used by any other applications, e.g. `rsoutdp`, as two applications cannot use the same port simultaneously.

Only the **DataDistrib.exe** file must be installed on the PCs where the application should run. Settings are stored in **DataDistrib.ini**.

Figure 46 *DataDistribution user interface*

Source Port	Source File	Packets	Destination : Port	Destination : Port	Destination : Port	Destination : Port	Destination File
0		-1					
0		-1					
0		-1					
0		-1					
0		-1					
0		-1					
0		-1					
0		-1					
0		-1					
0		-1					
0		-1					

Ver 1.1.0.14

Remote datagrams

These datagrams allow external systems a minimal amount of control of SIS. The datagrams are received by SIS in port 4001 and 4002, from the connected network using the UDP protocol.

Datagram	Received on port	Description
R00	4002	SIS to stop pingning (and logging if on)
R10	4002	SIS to stop all logging, but continue or start pinging
R12	4002	SIS to start logging on new line
R20	4001	Echosounder to send installation, runtime and sound speed profile (I, R and U) datagram

Note

The Rxx datagrams must always contain the sounder type i.e. EMX=dddd . “dddd” is described in Model number – code mapping table on page 572.

SIS supports for the following remote datagrams:

R00, R10 and R12

R00, R10 and R12 closely mimic the use of the logging and ping buttons. There are no restrictions on the sequence in which these datagrams can be sent. The following is typical:

- To start pinging: R10
- To start logging: R12 (Note that it is not necessary to start pinging with R10 first)
- To stop logging: R10 or R00. (Note R00 also stops pinging)
- To stop pinging: R00

When the remote **Rxx** datagrams are received the sounder type indicated in the datagram is made current. The SIS GUI is updated accordingly so that the ping and logging buttons will show the correct status.

The PLL parameter in the **R12** datagram can now be used to set the line number to be logged. The line number must be 4 digits between 0000 and 9999. Any non digit characters in the line number will result in PLL being disregarded. If no specific line number is wanted PLL should be set to empty, i.e. **PLL=**,

Note

No characters between the equal sign and comma

Note

The relevant echo sounder must have been started for the R00, R10 and R12 datagrams to have any effect. SIS will behave as if the ping and logging buttons have been used, including line counter increment.

R20

R20 is used to get an echo sounder (PU) to transmit the setup parameters currently used (i.e. **I**, **U**, **R** datagrams). These parameters are normally distributed by the PU to the external system(s) using its UDP4 port.

Note

The relevant echo sounder must have been started for the R20 datagram to have any effect.

Notification of SIS pinging and logging activity

It is possible for an external system to subscribe to the pinging and logging status changes in SIS. This makes it possible for the external system to mimic (shadow) these SIS operations.

A simple scheme to notify external systems of the pinging/logging status changes is to use the remote R-datagrams as these will give the necessary information:

- R00 System to stop pinging (and logging if on)
- R10 System to stop logging (but continue or start pinging)
- R12 System to start logging on new line

See *Remote datagrams* on page 568

Note

The original purpose of the R-datagrams is to be able to remotely control the SIS pinging and logging activity. However, using the R-datagrams for status change notification as described in this chapter does not conflict with this purpose.

SIS will prepare and send R-datagrams according to changes in logging and pinging status. External systems that require notification of these events must subscribe to these datagrams by using the datagram distribution feature in SIS.

See *Request datagrams from an echo sounder* on page 559

Note

The “All” send option must be used for the R-datagrams when setting up the parameters.

The use cases below indicate which R-datagrams an external system may receive due to pinging/logging status changes in SIS. Note that this is not a complete list.

SIS turns logging on

- Case 1: R12 (logging on)
- Case 2: R10 (pinging on) + R12 (logging on)

SIS turns logging off

- Case 1: R00 (pinging off logging off)
- Case 2: R10 (logging off, pinging still on)

SIS logs several consecutive lines (without breaks)

- Case 1: R12 + R12 + ... + R12 + ...

Note

It is important, in order to get a correct and complete status of the SIS logging activity, that all R-datagrams, including R00, must be subscribed to. R00 will indicate stop of pinging, but as a consequence, logging will also stop.

The format of the R-datagrams are defined in the Datagram formats document (reg nr 850 – 160692). For simplicity it is shown below, however always refer to the document in mention for a valid format.

Data Description	Format	Valid range	Note
Start identifier = \$	Always 24h	—	—
Talker identifier	aa	Capital letters	—
Datagram identifier	Rxx,	R00 to R20	1
EM model number	EMX=dddd,	—	—
Responsible operator	ROP=a–a,	—	—
Survey identifier	SID=a–a,	—	—
Survey line number	PLN=d..d,	—	—
Survey line identifier (planned line no)	PLL=d–d,	—	—
Comment	COM=a–a	—	—
Optional checksum	*hh	—	—
End of datagram delimiter = \CRLF	5Ch 0Dh 0Ah	—	—

The following parameters are not used in this context, i.e. no values are supplied by SIS for:

- ROP
- PLL

The rest of the parameters are used and contain parameters as described in the format.

Example, for an EM 3002 echo sounder:

```
$KMR12,EMX=3020,ROP=,SID=Fallback_3002_121_1,PL
N=0006,PLL=,COM= Serial number: 121*cc\CRLF
```

Where **cc** are two hex characters calculated by XOR'ing all characters between \$ and *.

The **Talker identifier** will be set to “KM”.

The format description above is inadequate to handle several echo sounders simultaneously, as it has no parameter to list the serial number of an echo sounder. This number has been put in the comment field (COM=) for completeness (e.g. **COM= Serial number: 121** in the example above).

Model number – code mapping table

The EM model number “dddd” is coded as follows:

System	Code	Note
EM 120	0120	—
EM 122	0122	—
EM 300	0300	—
EM 302	0302	—
EM 710	0710	—
EM 1002	1002	—
EM 2000	2000	—
EM 3000	3000	—
EM 3002	3020	NB!
ME70/BO	0850	NB!

Note

The codes for EM 3002 and ME70/BO differs from their respective system names.

Performance requirements

The interval between the distributed R-datagrams is undefined, i.e. the datagrams are asynchronous. The initial (startup) status may be assumed to be pinging and logging both off.

External interface requirements

The datagram distribution mechanism in SIS uses UDP. Note that SIS, in future releases, may operate several echo sounders in parallel. This implies that SIS can distribute the pinging/logging status from several echo sounders simultaneously (see the remark about the comment field (COM=) above).

In case of several echo sounders the information (i.e. R-datagrams) from each echo sounder can be distributed to separate IP:port address or alternatively all can use the same address. This must be decided before setting up the datagram subscription (i.e. distribution) parameters in SIS.

It is the responsibility of the external operator and the external system to set up and handle the incoming flow of pinging/logging status data from SIS. The EM model number can be used, if necessary, to distinguish between echo sounders using the same IP:port address.

Difference in log file formats

SIS logs various types of datagrams from the echo sounder in a continuous stream. Each time you start a new line, a new survey data file is created which results in a break in the data stream such that a depth datagram may be located at the end of one file with its associated position datagram located at the beginning of the next.

When SIS generates xyz-data from these files, if it encounters a depth datagram at the end of the file for which there is no corresponding position datagram, it looks for the missing position datagram in the next survey file. However, when Neptune generates xyz-data from these files, if it can't find a valid position datagram after the last depth datagram, it will reject the depth datagram resulting in a hole in the data.

Previous versions of the Merlin logging system handled this situation by storing duplicate position datagrams in both survey files, but this is no longer done. Therefore, to eliminate this type of hole when generating xyz-data, Neptune will be updated with a tool that will insert the missing position datagram at the proper location in the survey data files.

Barometer input

Preparations for use

If automatic update of the barometer (Offset) parameter is required (used in ROV operation for EM 3002) it is necessary to prepare SIS to receive this information.

The external barometer equipment/system must be connected to a vacant RS232 input port on the SIS HWS. This serial port must be configured: **Tools**→**External Sensors**

Barometer input format

The (current) format of the data received on the serial port is as follows:

```
*ddspppp.ppp<cr><lf>
```

Where:

*	The format always starts with an asterisk (*)
dd	a two digit destination identifier
ss	a two digit source identifier
pppp.ppp	pressure in mbar. Number of digits before and after the decimal point may vary
<cr><lf>	Terminating carriage return and line feed charactersft W

If this input format needs to be changed it is possible to adapt SIS to the new format without a full SIS upgrade. A separate conversion process is used for this purpose. This process is implemented using Perl, a programming language which can be used with all SIS installations. An editor and knowledge of Perl is all that is needed to adapt the conversion process:

- 1 Stop SIS if running
- 2 Go to the SIS program installation directory (e.g. "C:\Program Files\Kongsberg Maritime\SIS\bin" on Windows). Locate the file **barometerconv.pl** and open it in an editor. Do the necessary changes to adapt to the changed input format.
- 3 Save and close the edited file
- 4 Start SIS

The required output from the conversion process is a string of the following format:

```
$KSSIS,134,ss,dd,pppp.ppp\n\r
```

where the pressure has been converted to decibar of format pppp.ppp, and the number of digits before and after the decimal point may vary.

"\n\r" is linefeed and carriage return.

Parameter references

- *ROV Specific for EM 2040* on page 291

K-Sync interface

The numerical display frame in SIS contains an element for showing status information from the K-Sync (Synchronization Unit) product.



K-Sync is used to control the pinging operation of several echo sounders on the same vessel to avoid interference between them. K-Sync consists of a dedicated embedded computer that generates time critical trigger control signals and receives feedback from each managed echo sounder. The embedded K-Sync computer is controlled by a K-Sync application program running on a separate computer.

SIS and the K-Sync application program are normally installed on different computers. As a consequence it is of interest to be able to show the K-Sync status information directly in the SIS GUI environment. The K-Sync status is therefore sent to SIS via the Ethernet network using UDP and receiver port 4002 on the SIS HWS. The status is updated whenever a change occurs, and at least every 5th second. If a status message from an echo sounder is not received by SIS within a 10 second interval the status element for that echo sounder is blanked, i.e. set to the background colour.

In the SIS GUI the K-Sync status information is displayed in the Numerical frame. Initially, there is no K-Sync status information visible. This information will only be displayed after having received the first K-Sync status message. This is done to avoid having to configure SIS for the situation where a K-Sync installation is not used and hence no K-Sync display elements should be present.

The SIS K-Sync status display in SIS consists of seven colour elements. The colour indicates the K-Sync status according to the following scheme:

- Background (grey) – Disabled
- Green – Ready
- Dark green – Trigger and Busy after Trigger
- Yellow – Busy (explicit Busy status, not as a result of Trigger)
- Red – Error

Note

Some of the status colours used in SIS do not correspond to the colours used for the same status in the K-Sync application program. This is due to different colouring schemes. In SIS red is used for errors and off situations, whereas in K-Sync this is Busy. In SIS Dark green is used for both Trigger and Busy after Trigger.

By positioning the cursor on top of one of the coloured status elements the echo sounder name associated with that element will be shown.

Note

The K-Sync product is able to control up to 16 different synchronization elements (e.g. echo sounders). SIS will currently only be able to report/display the seven first. This will normally be adequate for most configurations.

Port allocation

The network ports listed in the following are allocated for SIS and the echo sounder system, and must not be used by other systems on the network.

SIS ports

SIS allocates ports dynamically from port number 16000 and upwards. Number of dynamically allocated ports depends on number of detected echo sounders.

Port number	Defined for
2012	Simulator input to PU.exe
4001	Internal datagrams to CCU from other SIS modules
4001	External SSP datagrams
4001	External \$KSSIS.080 sound velocity at transducer datagrams
4001	External \$ATIDE realtime tide datagrams
4001	R20 remote datagram, used to request currently used setup parameters from the PU
4002	Internal datagrams to GUI from other SIS modules
4002	R00, R10 and R12 datagrams for remote control of the PU
4002	K-Sync status information
4003–4007	Miscellaneous allocated sockets for internal SIS use
4006	Internal use by PU.exe
4008	Internal use by CUBE
4009	Internal use by Helm.exe
4012	Not fixed, but normally used for the Global Event Marker Clients
4310	NMEA DPT datagram output
4312	Internal use by ShapeFiles Reader
4043–4445	Internal use by SVP Logger
4603	Internal use by HDDS
5050	DDS to Helmsman display
5051	Helmsman display to autopilot
5052	Helm.exe
5053	Helm.exe
5055	CCU to SSV (Surface Sound Velocity)
5056	SSV to CCU
5057	SSV to RStoUDP
5058	RStoUDP to SSV
5060	Internal use by CCU and SVP Editor
5061	Internal use by CCU
5558	Licence server
5689	Internal use by KSGPL/SIS Objects
7010	HDD to GridEngine
8080	GridEngine
9001–9013	Miscellaneous allocated sockets for internal SIS use
10183	EA listens for CS datagrams

Port number	Defined for
15052	Internal use by Helm.exe
15201	Internal use by RStoUDP
15800	Internal use by CUBE
16xxx–	Dynamically allocated ports

PU ports

Port number	Defined for
1999	EA input
1999	PU broadcast
2012	Remote control of PU
2022	UDP2
2032	UDP3
2042	UDP4
2999	Dummy port number displayed to indicate the the PU is logging to disk. For internal use.
Dynamical	Host UDP port 1. Used by SIS for PU command responses and status.
Dynamical	Host UDP port 2. Used by SIS for logging of survey data (to .all files). See <i>PU communication – Output setup</i> on page 279.
Dynamical	Host UDP port 3. Used by SIS for update of realtime display info, e.g. beam intensity, time series, etc.
Dynamical	Host UDP port 4. Used by SIS for user defined logging purposes. See <i>PU communication – Output setup</i> on page 279.

Attitude sensors

Port number	Defined for
3000	CodaOctopus F180
3001	Seapath 200 default (configurable)
5602	POSMV output

ATH (Applanix True Heave)

Port number	Defined for
5070	ATH to CCU
5071	CCU to ATH
5602	POSMV output

SRH (Seapath Real Heave)

Port number	Defined for
5075	SRH to CCU
5076	CCU to SRH
31102	Input from Seapath

RTCM Logging

Port number	Defined for
5081	CCU to RTCMLogger
5082	RTCMLogger to CCU
31103	Input from Seapath

Appendix A Terminology and abbreviations

Terminology

All multibeam echo sounder systems use transducer arrays but in some models the transducers are integrated in sonar heads.

→Refer to the installation manual to find out more about your system .

Abbreviations

The following abbreviations are used in this document:

1PPS

One Pulse Per Second synchronization signal

ABDC

Area Based Data Cleaning

APB

NMEA Autopilot format B sent by SIS/planning stations to allow them to be used to control an autopilot unit

AUV

Autonomous Underwater Vehicle

BD

Bottom detection

BIST

Built-In Self Test

BS

Backscatter

BSP

Beamforming and Signal Processing

CCU

Central Command Unit, a SIS background process that controls all echo sounders

CMG

Course made good, course from beginning of planned line

COG

Course over ground

CPU

Central Processing Unit

CUBE

Combined Uncertainty and Bathymetry Estimator, an alternative data gridding method

CW

1 Clockwise

2 Continuous Waves (describing pulse properties)

CCW

Counterclockwise

DBS

NMEA datagram; Depth below surface

DBT

NMEA datagram; Depth below transducer

DDS

Data Distribution System; a SIS background process responsible for logging datagrams sent by the echo sounders

DPT

NMEA datagram; Depth

DST

Distance to end of line

DTK

Desired track, direction of planned line

DTM

Digital Terrain Model

DXF

Data Exchange File, a three-dimensional graphics file format

EA

A type of singlebeam echo sounder

EM

A type of multibeam echo sounder

ETA

Estimated time of arrival

GGA

NMEA position datagram

GGK

NMEA position datagram

GMT

Greenwich Mean Time

GPS

Global Positioning System (in this manual GPS includes all kinds of positioning systems)

GUI

Graphical User Interface

HDSS

Handle Data Distribution System; a SIS background process that reads data from disk and process the data to xyz for SIS gridding

HDM

NMEA datagram; Heading, magnetic

HDOP

Horizontal Dilution Of Precision read from position datagrams

HDT

NMEA datagram; Heading, true

HWS

Hydrographic Work Station; the SIS operator PC

IP

Internet Protocol

IRLS

Iterated Reweighted Least Squares

KSGPL

Kongsberg SIS Graphic Programming Language

LBDC

Line Based Data Cleaning

LOD

Level Of Detail

ODBC

Open DataBase Connectivity, a standard database access method

OpenGL

A 3-D graphics language

PU

Processing Unit (for multibeam echo sounders with a Transceiver Unit, the PU is included in the TRU)

RAM

Random access memory

RGB

Red, green and blue (primary colours on a computer monitor)

ROV

Remotely Operated Vehicle

RTDC

Real Time Data Cleaning, the real time processing tool in SIS

RTK

Real Time Kinematic

RX

Receiver

SCSI

Small Computer System Interface, a parallel interface standard

SH

Sonar Head

SIS

Seafloor Information System, the front-end for all echo sounders

SISDB

SIS Database, the database used by SIS to store parameters

SOG

Speed over ground

SQL

Structured Query Language, a standardized query language for requesting information from a database

SSP

Sound speed datagrams used by SIS (Sxx datagrams)

SV

Sound velocity

SV&P

Sound velocity and depth (pressure) sensor

SV&T

Sound velocity and temperature sensor

TCP

Transmission Control Protocol

TRU

Transceiver Unit

TVG

Time Variable Gain

TVG FG

TVG Fixed Gain

TVG NIB

TVG Normal Incidence Backscatter

TVG OB

TVG Oblique Backscatter

TVG RN

TVG Range To Normal Incidence

TX

Transmitter

UDP

User Datagram Protocol, a connectionless protocol

UPS

Uninterrupted Power Supply

UTC

Universal Time Coordinated

UTM

Universal Transverse Mercator (a common projection used in map presentations)

VRML

Virtual Reality Modeling Language, a specification for displaying 3-D objects

WGS84

World Geodetic System 1984

XTE

Cross track error, measured, distance to planned line

ZDA

NMEA datagram; UTC and local date/time data

Appendix B INDEX (Interactive)

A

About SIS, 392
 About this manual, 13
 Absorption coefficient, 504
 Equation, 512
 actd, 548
 Advanced parameters, 297
 AHT logging, 323
 Angular offsets, 274
 EM 2040, 290
 Annotation colours, 49
 APOS, 347
 Artefacts causing errors, 509
 asvp, 544
 ATH data format, 551
 ATH logging, 325
 Attitude velocity, 276
 Auto pilot, 375
 Output setup, 375
 Parameters, 343
 Automatic
 BIST, 154
 Startup, 154
 Autostart, 154
 AUV/ROV, 460

B

Barometer, 574
 Input setup, 375
 Beam intensity, 61
 Buttons, 61
 Show/Hide, 227
 Toolbar, 61
 Beam pointing angles, 527
 BIST, 293
 Built-In Self Test, 293
 Buttons, 35
 Annotation colours, 49
 Beam intensity, 61
 Calibration, 100
 Colour coded depth, 63
 Common, 48
 Cross track, 64
 Dynamic colours, 50
 Geographical, 57
 Helmsman Display, 70
 Print, 51
 Scale, 53
 Scope display, 81
 Seabed image, 66
 Sensor layout, 98
 Sound velocity, 79
 Stave display, 83
 Time series, 72
 Water column, 78
 Waterfall, 73
 Zoom and view, 51

C

C-Map, 443
 Cartographic service, 445
 CM-93/3 compiler, 443
 Detail level, 41
 Installation notes, 16
 Licence Administration, 379
 Manipulation mode, 225
 Min performance, 443
 S-57 verifier, 443
 What it does, 443
 Calibration, 100
 Area, 171
 AutoCalib Wizard, 380
 Automatic, 180
 Buttons, 100
 Dual head, 188
 Edit mode, 224
 Enable calibration mode, 181
 Heading offset, 176
 How to use SIS
 Calibration, 181
 Keyboard, 46
 Mouse, 46
 Outer beam angle
 calibration, 178–179
 Parameters, 260
 Pitch offset, 174
 Principles, 171
 Roll offset, 173
 SeaCal, 409
 Seacal parameters, 261
 Seacal results, 381
 Show/Hide, 261
 Sound velocity quality
 inspection, 178
 Time delay, 174
 Toolbar, 100
 Verification, 180
 Changing behaviour of
 notification messages, 558
 Colour coded depth, 63
 Buttons, 63
 Show/Hide, 227
 Toolbar, 63
 Colour palette, 41
 Common display buttons, 48
 Annotation colours, 49
 Dynamic colours, 50
 Print, 51
 Scale, 53
 Zoom and view, 51
 Convention, 496
 Coordinate system
 Vessel, 496
 Create terrain models, 451
 Cross track, 64
 Buttons, 64

Display options, 227
 Modeless operation, 64
 Toolbar, 64

CUBE, 464
 Create grid, 369
 Description, 464
 Export survey data, 471
 Features not supported, 475
 Geographical view, 473
 Import raw data, 470
 User interface, 470
 Current echosounder, 36
 Custom menu, 106

D

Data cleaning, 317
 DTM processing rules, 320
 Grid processing rules, 321
 Ping processing rules, 319
 Reference, 492
 Seabed Image
 Processing, 322
 Data distribution, 567
 Datagram formats, 529
 Distribution, 567
 Remote, 568
 Request, 559
 Request manually, 561
 SIS pinging and logging
 activity, 570
 SSP datagrams, 539
 Datum transformation, 384
 Dead reckoning, 525
 Delayed heave, 323
 Depth below keel, 376
 Depth profile output, 535
 Depth under keel format, 534
 Detecting the echo sounder
 on the network, 157
 Display, 25
 Annotation colours, 49
 Auto scale once, 54
 Colour palette, 41
 Dynamic colours, 50
 Fixed scale, 54
 Frames, 27
 General, 212
 Gridded data, 220
 Icons, 40
 KSGPL, 222
 Neptune based survey, 219
 Pause, 53
 Point data display, 221
 Print, 51
 Reset view, 53
 Scale, 53
 SIS based survey, 216

- Sonar display grid, 218
- Survey, 214
- The application window, 25
- Zoom, 51
- Zoom out, 52
- Zoom reset, 53
- Display options, 209
 - Beam intensity, 227
 - Calibration, 261
 - Colour coded depth, 227
 - Cross track, 227
 - Geographical, 211
 - Helmsman Display, 237
 - Scope display, 247
 - Seabed image, 231
 - Sensor layout, 258
 - Ship definition, 334
 - Sound velocity, 247
 - Stave display, 249
 - SVP Editor, 396
 - Time series, 238
 - Water column, 243
 - Waterfall, 241
- DP, 376
- DPT format, 534
- DTM processing rules, 320
- Dynamic colours, 50
- Dynamic positioning, 376
- E**
- Echo sounder
 - Current, 36
 - Not started, 35
- EM 2040
 - Angular offsets, 290
 - BIST, 294
 - Filter and gains, 310
 - ROV specific, 291
 - Scope display
 - parameters, 330
 - Simulator, 329
 - Sound speed, 305
 - Sounder main, 297
 - System parameters, 292
- Error estimate format, 530
- Error estimates, 346
- Events, 447
- Exit, 370
- Export data, 206
- Export formats, 531
- Export survey results, 207
- External datagram (C+T)
 - format, 550
- External sensors, 371
 - Heading and position, 138
 - How to, 137
 - Input setup, 372
 - Output setup, 375
 - Sound velocity probe, 137
- Extract IFF, 381
- F**
- File
 - Background grid, 359
 - Create CUBE grid, 369
 - Delete settings, 364
 - Export, 352
 - Export data files, 359
 - Export PU parameters, 364
 - Export user settings, 368
 - Import, 352
 - Import PU parameters, 366
 - Import user settings, 369
 - KSGPL, 359
 - Parameters, 352
 - Raw data files, 355
 - Remove sounder, 362
 - Remove survey, 362
 - Save settings, 363
 - Save settings as..., 363
 - Set startup settings, 364
 - xyz file, 361
- File formats, 529
 - actd format, 548
 - asvp format, 544
 - ATH, 551
 - Barometer input, 574
 - C+T format, 550
 - Depth profile output, 535
 - Depth under keel, 534
 - Difference in log file
 - formats, 573
 - DPT, 534
 - Error estimate formats, 530
 - Export formats, 531
 - Notification messages, 558
 - Sound speed and density
 - profile format, 548
 - Sound speed profile
 - format, 544
 - SRH, 555
 - Survey plan, 538
 - Terrain referenced
 - position, 536
 - TerraPOS, 556
 - TPU formats, 530
- File menu, 104
- Filter and gains, 297
 - EM 2040, 310
- Frames, 27
 - Beam intensity, 61
 - Calibration, 100
 - Colour coded depth, 63
 - Contents, 55
 - Cross track, 64
 - Geographical, 57
 - Helmsman display, 70
 - Installation parameters, 94
 - Message service, 69
 - New survey, 89
 - Numerical display, 68
 - Parameters, 209
 - Planning, 93
 - PU sensor status, 86
 - Runtime parameters, 95
 - Runtime parameters
 - Mini, 96
 - Scope display, 81
 - Seabed image, 66
 - Sensor layout, 98
 - Sound velocity profile, 79
 - Stave display, 83
 - Survey administration, 91
 - Tear-off windows, 39
 - Time series, 72
 - Toolbar, 35
 - Water column, 75
 - Waterfall, 73
- G**
- Generic Sensor Format, 483
- Geodimeter, 375
- Geographical, 57
 - 2D or 3D, 223
 - Buttons, 57
 - C-Map manipulation
 - mode, 225
 - Calibration edit mode, 224
 - Compass, 223
 - CUBE features, 473
 - Display smooth surface, 165
 - Display sound vel. at
 - TD depth, 163
 - Follow ship, 224
 - General display, 212
 - Geotiff background data, 166
 - Grid shading, 222
 - Gridded data display, 220
 - Information field, 225
 - Inspection mode, 223
 - Keyboard, 44
 - KSGPL display, 222
 - KSGPL edit mode, 223
 - Level of detail, 225
 - Load background data, 224
 - Look for artefacts, 165
 - Modeless operation, 58
 - Mouse, 44
 - Neptune based survey, 219
 - Options, 211
 - Planning mode, 224

- Point data display, 221
 - Quick menu, 59
 - Save background image, 224
 - Seabed imagery display, 162
 - Show depth under
 - cursor, 222
 - Show position under
 - cursor, 223
 - SIS based survey
 - display, 216
 - Sonar display grid, 218
 - Survey display, 214
 - Toolbar, 57
 - Zoom to active survey, 52
 - Zoom to given region, 52
 - Zoom to ship, 52
 - Zoom to world, 52
 - Zooming, 52
 - Geoid, 515
 - Global event marker, 447
 - GPS, 323
 - GPS raw data logging
 - RINEX, 476
 - RTCM 3.0, 476
 - Graphical, 25
 - Frames, 27
 - The application window, 25
 - Windows, 27
 - Grid, 341
 - Create from ASCII, 451
 - CUBE parameters, 273
 - GridEngine, 490
 - GridEngine parameters, 269
 - Set data cleaning
 - method, 341
 - Grid processing rules, 321
 - GSF
 - Support in SIS, 483
 - GSF Converter
 - How to use, 483
- H**
- Heading input, 374
 - Helmsman Display, 70
 - Buttons, 70
 - How to, 206
 - Show/Hide, 237
 - Toolbar, 70
 - Help menu, 107
 - Hotkeys, 46
 - How to, 108
 - APOS into SIS, 347
 - Calibrate a dual head
 - system, 188
 - Calibration, 181
 - Change SIS language, 112
 - Collect the sound
 - velocity profile, 141
 - Configure survey, 113
 - Convert format using
 - macro in the SVP
 - Editor, 149
 - Convert format using
 - SVP Editor, 147
 - Convert SVP format, 143
 - Create and use a geotiff
 - background picture, 166
 - csv2asvp, 143
 - Display a smooth
 - surface, 165
 - Display planned lines, 206
 - Display realtime depths, 161
 - Display seabed imagery
 - data, 162
 - Display sound velocity
 - at transducer, 163
 - Enter survey parameters, 114
 - Exit SIS, 207
 - Export data, 206
 - Export survey results, 207
 - External sensors, 137
 - GPS clock and orbit, 478
 - Import a Neptune grid, 159
 - Installation parameters, 127
 - Interface an EA into SIS, 155
 - Interfaces to HWS, 137
 - Log stave data, 170
 - Log water column data, 170
 - Look for artefacts, 165
 - Modify and load a SVP, 151
 - Monitor the external
 - sensors, 160
 - Monitor the progress, 202
 - New survey, 118
 - Open the installation
 - parameters, 126
 - Open the runtime
 - parameters, 134
 - Plan a new job, 201
 - Precise Point
 - Positioning, 478
 - Projection and datum, 122
 - Retrieve a planned job, 202
 - Run the PU simulator, 203
 - Run the survey, 202
 - Runtime parameters, 134
 - Save data, 169
 - SeaCal, 184
 - Setup enter the waterline
 - for EA, 139
 - Setup the output to
 - external sensors, 139
 - SmartTalk, 142
 - Start and stop logging, 169
 - Start pinging, 160
 - Start SIS, 112
 - Start the echo sounder, 154
 - Start the remote
 - helmsman display,
 - 206
 - Survey parameters, 114
 - SVP Logger, 143
 - SVP Manager, 145
 - Terrapos, 478
 - Use SIS on AUV/ROV, 460
 - Verify the EM main
 - functions, 161
 - Hypack ®, 22
- I**
- Icons, 40
 - Import grids to SIS, 451
 - Installation parameters, 274
 - Active sensors
 - parameter settings,
 - 287
 - Angular offsets EM
 - 2040, 290
 - Attitude sensor
 - parameter settings,
 - 285
 - BIST, 293
 - Clock setup, 281
 - COM port parameters, 275
 - Description, 94
 - How to, 127
 - Input setup, 275
 - Location of sensors, 288
 - Motion sensor parameter
 - settings, 285
 - Multicast, 278
 - Network addresses, 276
 - Output setup, 279
 - Positioning systems
 - parameter settings, 283
 - Procedures, 125
 - ROV specific EM 2040, 291
 - Sensor setup, 283
 - System parameters EM
 - 2040, 292
 - System report, 296
 - UDP port parameters, 275
 - UDP5 – UDP6, 276
 - Instrument combinations, 377
 - Interface, 371
 - Auto pilot, 375
 - Barometer, 375
 - Depth below keel, 376
 - Dynamic positioning, 376
 - Geodimeter, 375

- Heading, 374
 - How to, 137
 - Instrument
 - combinations, 377
 - Position, 374
 - Real time tide, 373
 - Remove instruments, 378
 - Sound velocity, 373
 - SVP logger, 375
 - Intermediate File Format, 381
 - Introduction, 15
- J**
- Javad
 - Details, 520
- K**
- Keyboard, 43
 - Calibration, 46
 - Geographical, 44
 - Planning, 44
 - Sensor layout, 45
 - Sound velocity profile, 45
 - Water column, 46
 - Waterfall, 45
 - KSGPL, 453
 - Edit mode, 223
 - Load background data, 224
 - Object types, 222
 - SIS objects, 417
- L**
- Level of detail, 225
 - Licences, 16
 - Line counter, 37
 - Logging, 169
 - Formats, 573
 - How to, 154
 - Notification, 570
 - Sound velocity data, 141
 - To PU disk, 461
 - Water column, 247
 - Logging utilities, 435
 - Command based PU
 - sockets logging, 440
 - Command based SIS
 - sockets logging, 436
 - SIS data logger for PU
 - sockets, 439
 - SIS data logger for SIS
 - sockets, 435
 - SIS sockets, 435
- M**
- Main menu, 103
 - Main toolbar, 33
 - Mean sea surface, 515
 - Menu, 103
 - Configure, 382
 - Custom menu, 106
 - File menu, 104
 - Help, 107
 - Main menu, 103
 - Tools, 105
 - Tools menu, 371
 - View, 105
 - Message service, 69
 - Mouse, 43
 - Calibration, 46
 - Geographical, 44
 - Planning, 44
 - Sensor layout, 45
 - Sound velocity profile, 45
 - Water column, 46
 - Waterfall, 45
- N**
- Neptune, 159
 - Network licence, 345
 - New survey, 89
 - Background data, 267
 - Basic parameters, 263
 - GridEngine parameters, 269
 - How to, 118
 - Parameters, 263
 - Projections, 269
 - Storage options, 265
 - Notification of pinging and logging, 570
 - Numerical display, 68
 - Numerical Display
 - Parameters, 232
- O**
- Objects, 417
 - Overview, 15
 - System information, 16
- P**
- Palette controller, 41
 - Parameters, 209
 - Active sensors, 287
 - Angular offsets EM 2040, 290
 - ATH logging, 323, 325
 - Attitude sensors, 285
 - Attitude velocity, 276
 - BIST, 293
 - Calibration, 260
 - Clock setup, 281
 - COM port, 275
 - Data cleaning, 317
 - Datum, 384
 - Delayed heave, 323
 - File menu, 352
 - Filter and gains EM 2040, 310
 - Frames, 209
 - GPS, 323
 - Help menu, 390
 - Input setup, 275
 - Installation, 274
 - Motion sensors, 285
 - Multicast, 278
 - Network addresses, 276
 - New Survey, 263
 - Numerical display, 232
 - Output setup, 279
 - Positioning systems, 283
 - PPP logging, 327
 - Projection, 384
 - Projections, 269
 - ROV specific EM 2040, 291
 - RTCM logging, 324
 - Runtime, 297
 - Runtime Mini, 96
 - Scope display, 330
 - Secal, 261
 - Sensor locations, 288
 - Sensor setup, 283
 - Ship definition, 334
 - Simulator EM 2040, 329
 - SIS parameters, 333
 - Sound speed EM 2040, 305
 - Sounder main EM 2040, 297
 - SRH logging, 326
 - Survey administration, 263
 - Survey information, 332
 - System parameters EM 2040, 292
 - System report, 296
 - Tools menu, 371
 - UDP port, 275
 - Password, 338
 - Ping processing rules, 319
 - Pinging, 160
 - Notification, 570
 - Planning, 93
 - Edit mode, 224
 - File format, 538
 - How to, 199
 - Jobs, 251
 - Keyboard, 44
 - Mouse, 44
 - New jobs, 201
 - Object, 251
 - Remote, 251
 - Retrieve a job, 202
 - Playback, 449

- Port definitions, 576
- Position, 335
 - Dead reckoning, 525
 - Input, 374
 - Jump filter, 525
- Position under cursor, 223
- PPP, 476
- PPP logging, 323, 327
- Precise Point Positioning, 476
 - General description, 476
 - Procedure, 478
 - SIS, 478
 - Terrapos, 477
- Predicted tide file format, 518
- Print, 51
- Procedures, 108
 - Advanced survey parameters, 119
 - Advanced survey template parameters, 115
 - APOS into SIS, 347
 - Automatic BIST at echo sounder startup, 154
 - Background data, 114
 - Basic survey parameters, 118
 - BIST, 133
 - Check echo sounder main functions, 161
 - Check installation and runtime parameters, 125
 - Check sensor input, 160
 - CUBE parameters, 117
 - Data cleaning, 136
 - Datum transformation, 122
 - Detecting the echo sounder, 158
 - Enter a sound velocity profile, 139
 - Enter operator parameters, 113
 - Enter survey parameters, 113–114
 - Exit SIS, 207
 - Export data files, 359
 - Export survey results, 207
 - External sensor, 136
 - Filter and gains, 135
 - GPS clock and orbit, 478
 - Heading offset calibration, 176
 - How to calibrate a dual head system, 188
 - How to change language of SIS, 112
 - How to collect the sound velocity, 141
 - How to configure your survey, 113
 - How to convert a profile using SVP Editor, 147
 - How to convert the SVP format, 143
 - How to create and use a geotiff background picture, 166
 - How to define a new projection, 122
 - How to display a smooth surface, 165
 - How to display planned lines, 206
 - How to display realtime depths, 161
 - How to display seabed imagery data, 162
 - How to display sound velocity at transducer, 163
 - How to do a calibration, 181
 - How to enter parameters for a new survey, 118
 - How to enter survey parameters, 114
 - How to export data, 206
 - How to export survey results, 207
 - How to import a Neptune grid, 159
 - How to interface an EA into SIS, 155
 - How to log stave data, 170
 - How to log water column data, 170
 - How to look for artefacts, 165
 - How to modify and load a SVP, 151
 - How to modify the installation parameters, 127
 - How to modify the runtime parameters, 134
 - How to monitor the external sensors, 160
 - How to monitor the progress, 202
 - How to open the installation parameters, 126
 - How to open the runtime parameters, 134
 - How to plan a new job, 201
 - How to retrieve a planned job, 202
 - How to run the PU simulator, 203
 - How to run the survey, 202
 - How to save data, 169
 - How to setup enter the waterline for EA, 139
 - How to setup the input from external sensors, 137
 - How to setup the output to external sensors, 139
 - How to start pinging, 160
 - How to start SIS, 112
 - How to start the echo sounder, 154
 - How to start the remote helmsman display, 206
 - How to use csv2asvp, 143
 - How to use macros to convert a profile using SVP Editor, 149
 - How to use SeaCal, 184
 - How to use SIS Calibration, 181
 - How to use SIS on AUV/ROV, 460
 - How to use SmartTalk, 142
 - How to use start and stop logging, 169
 - How to use SVP Logger, 143
 - How to use SVP manager, 145
 - How to verify the EM main functions, 161
 - Installation parameters interface, 126
 - Interface, 136
 - Normal operational sequence, 110
 - Outer beam angle calibration, 179
 - Perform a system calibration, 171
 - Pitch offset calibration, 174
 - Plan a survey, 199
 - Playback, 203
 - Precise Point Positioning, 478
 - Projection definition, 122
 - PU communication, 127
 - Remote Helmsman display, 206
 - Replay, 203
 - Roll offset calibration, 173
 - Runtime parameters interface, 133
 - Sensor setup, 130
 - Set projection, 113
 - Sound speed, 135
 - Sound velocity interface, 137
 - Sound velocity quality inspection, 178
 - Sounder main, 134

- Storage options, 119
- Survey templates
 - handling, 114
- System parameters, 132
- Terrapos, 478
- Time delay calibration, 174
- User handling, 114
- Projection, 384
 - Available ellipsoids, 386
 - Available projections, 387
 - How to, 122
 - Parameters, 269
 - Programming, 513
 - Reference, 513
 - Test, 385
 - Using PROJ.4, 513
- PU, 86
 - Clock parameters, 281
 - Export, 364
 - Factory settings, 367
 - Import, 366
 - Input parameters, 275
 - Open, 366
 - Output parameters, 279
 - Save, 364
 - Sensor status, 86
 - Simulator, 449
- Q**
- Qinsy ®, 22
- Quick menu, 59
- Quit, 370
- R**
- Raypaths chart, 401
- Real time data cleaning, 492
- Real time tide, 373
 - Datagram format, 518
- Registered trademarks, 14
- Remote datagrams, 568
- Remote Helmsman
 - display, 206
- Remove instruments, 378
- Replay, 449
- Request datagrams, 559
- Request datagrams
 - manually, 561
- ROV specific
 - EM 2040, 291
- RTCM logging, 324
- Runtime parameters, 297
 - ATH logging, 323, 325
 - Data cleaning, 317
 - Description, 95
 - Filter and gains EM 2040, 310
 - GPS and delayed heave, 323
 - How to, 134
 - PPP logging, 327
 - Procedures, 125
 - RTCM logging, 324
 - Simulator EM 2040, 329
 - Sound speed EM 2040, 305
 - Sounder main EM 2040, 297
 - SRH logging, 326
 - Survey information, 332
- Runtime parameters Mini, 96
- S**
- Scale, 53
 - Auto scale once, 54
 - Fixed scale, 54
- Scope display, 81
 - Buttons, 81
 - Show/Hide, 247
 - Toolbar, 81
- Seabed image, 66
 - Buttons, 66
 - Show/Hide, 231
 - Toolbar, 66
- Seabed Image Processing, 322
- Seacal, 409
 - How to, 184
 - Results, 381
 - Wizard, 380
- SeaCal
 - Parameters, 261
- SeaCast, 405
- Sensor layout, 98
 - Buttons, 98
 - Keyboard, 45
 - Mouse, 45
 - Show/Hide, 258
 - Toolbar, 98
- Set parameters, 333
 - APOS, 347
 - Auto pilot, 343
 - Display, 339
 - Error model, 346
 - Logging, 341
 - Network licence, 345
 - Password, 338
 - Positions, 335
 - Projections, 351
 - Sensor options, 348
 - Ship, 334
 - Sound speed, 344
 - Startup options, 350
 - Turn, 337
- Simulator, 297
 - EM 2040, 329
- SIS, 15
 - About, 392
 - Architecture, 487
 - As a controller, 22
 - Basics, 15
 - Build info, 391
 - Central Command Unit, 489
 - Configure, 382
 - Data Distribution System, 489
 - Database, 491
 - Graphical User Interface, 488
 - GridEngine, 490
 - Handle Data Distribution System, 489
 - Help, 391
 - Licences, 16
 - Logging formats, 573
 - Network licence, 345
 - OpenGL, 392
 - Operational principles, 21
 - Password, 338
 - Processes, 487
 - SISDB, 491
 - System drawing, 17
 - System information, 16
 - System overview, 18
- SIS data logger
 - PU sockets, 439
 - SIS sockets, 435
- SIS Objects, 417
- SIS overview, 18
 - Geographical window, 19
 - GPS RTK input, 20
 - Instrument control, 18
 - MBE support, 18
 - Precise point positioning, 21
 - Real time data cleaning, 19
 - ROV operations, 20
 - SBE support, 19
 - Seabed image, 20
 - SIS objects, 21
 - Water column imaging, 20
- SIS parameters, 333
- SIS sockets, 435
 - remarks, 437
- SmartTalk
 - How to, 142
- Sound speed, 297
 - EM 2040, 305
- Sound speed and density
 - format, 548
- Sound speed profile format, 544
- Sound velocity, 79
 - Buttons, 79
 - Collect, 141
 - Convert SVP format, 143
 - Editor, 395
 - Formulas, 502

- How to, 139
 - Keyboard, 45
 - Logging, 141
 - Mouse, 45
 - Procedures, 139
 - Quality inspection, 178
 - SeaCast, 405
 - Set parameters, 344
 - Show/Hide, 247
 - SVP Logger, 406
 - Toolbar, 79
 - Sounder main, 297
 - EM 2040, 297
 - SRH data format, 555
 - SRH logging, 326
 - SSP datagrams, 539
 - Status bar, 42
 - Stave display, 83
 - Buttons, 83
 - Logging, 249
 - Show/Hide, 249
 - Toolbar, 83
 - Stop, 370
 - Survey administration, 91
 - CUBE parameters, 273
 - GridEngine parameters, 269
 - Parameters, 263
 - Projections, 269
 - User handling, 272
 - Survey information, 332
 - Survey parameters, 263
 - How to, 114
 - Survey plan file format, 538
 - SVP Editor, 395
 - Convert a profile, 147
 - Convert a profile using macro, 149
 - Display, 396
 - File menu, 397
 - Modify and load to SIS, 151
 - Raypaths chart, 401
 - SVP effects, 401
 - Tools menu, 398
 - SVP Effects, 401
 - SVP logger, 375
 - SVP Logger, 406
 - How to, 143
 - System drawing, 17
 - System parameters, 274
 - EM 2040, 292
 - System report, 296
- T**
- Tear-off windows, 39
 - Technical reference, 486
 - Terrain referenced position, 536
 - Terrapos, 477
 - TerraPOS data format, 556
 - Tide, 518
 - Time series, 72
 - Buttons, 72
 - Clear plot, 241
 - Show/Hide, 238
 - Toolbar, 72
 - Timing, 498
 - Toolbar, 33
 - Beam intensity, 61
 - Calibration, 100
 - Colour coded depth, 63
 - Cross track, 64
 - Current echo sounder, 36
 - Frame toolbars, 35
 - Geographical, 57
 - Helmsman Display, 70
 - Line counter, 37
 - Main toolbar, 33
 - Not started, 35
 - Scope display, 81
 - Seabed image, 66
 - Sensor layout, 98
 - Sound velocity, 79
 - Status bar, 42
 - Stave display, 83
 - Time series, 72
 - Water column, 78
 - Waterfall, 73
 - Tools menu, 105
 - TPU format, 530
 - Trademarks, 14
 - Trimble
 - Details, 520
 - Turn parameters, 337
- V**
- Vessel coordinate system, 496
 - View menu, 105
- W**
- Water column, 75
 - Buttons, 78
 - Keyboard, 46
 - Logging, 247
 - Mouse, 46
 - Show/Hide, 243
 - Toolbar, 78
 - Waterfall, 73
 - Buttons, 73
 - Keyboard, 45
 - Mouse, 45
 - Show/Hide, 241
 - Toolbar, 73
 - Windows, 27
 - Contents, 55
- Z**
- Zoom, 51
 - Tear-off, 39

©2013 Kongsberg Maritime

**SIS - Seafloor Information System
Reference manual for EM 2040**

**SIS - Seafloor Information System
Reference manual for EM 2040**

**SIS - Seafloor Information System
Reference manual for EM 2040**