

38 kHz high power split-beam transducer

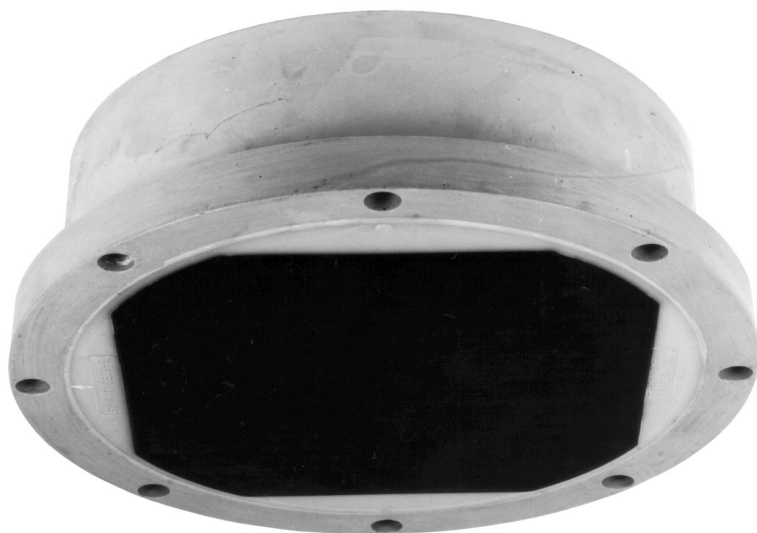

Introduction

The ES 38B is a split-beam transducer incorporating 88 piezo-ceramic elements distributed over four quadrants. The following specifications are provided with regard to all four quadrants connected in parallel.

Order number

KSV-074531

Technical specifications

Resonant frequency	38 kHz
Longitudinal beamwidth	7 ± 1 deg
Transversal beamwidth	7 ± 1 deg
Directivity index	28.0 ± 1 dB
Equivalent two-way beam angle	-20.5 ± 1 dB
Side lobes	less than -15 dB
Back radiation	less than -35 dB
Impedance:	
Nominal value	15 ohm
Max. variation in $ Z $	11 to 20 ohm
Max. variation in phase	± 30 deg
Transmitting response	185.5 ± 2 dB (dB re 1 μ Pa per V)

Receiving sensitivity:

Open circuit	-176.5 ± 2 dB (dB re 1V per μ Pa)
--------------	--

Electroacoustic efficiency:

Typical	70 %
Minimum	50 %
Maximum input power	4000 W
Maximum duty cycle at max power	1 %
Maximum transducer depth	50 m
Cable length	20 m
Cable diameter	18 mm
Weight (without cable)	40 kg
Storage temperature	+70 to -40° C

Data

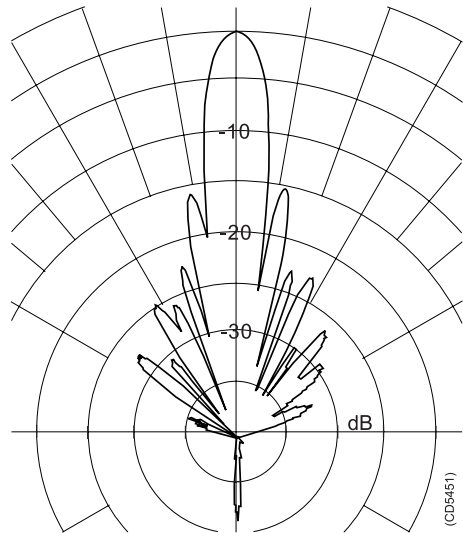
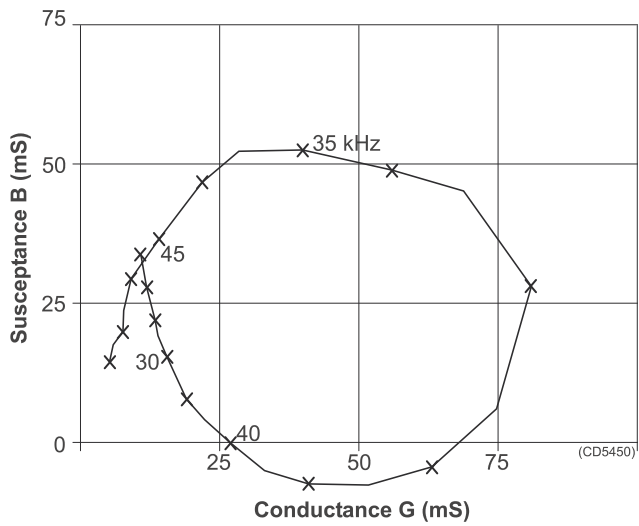

Installation

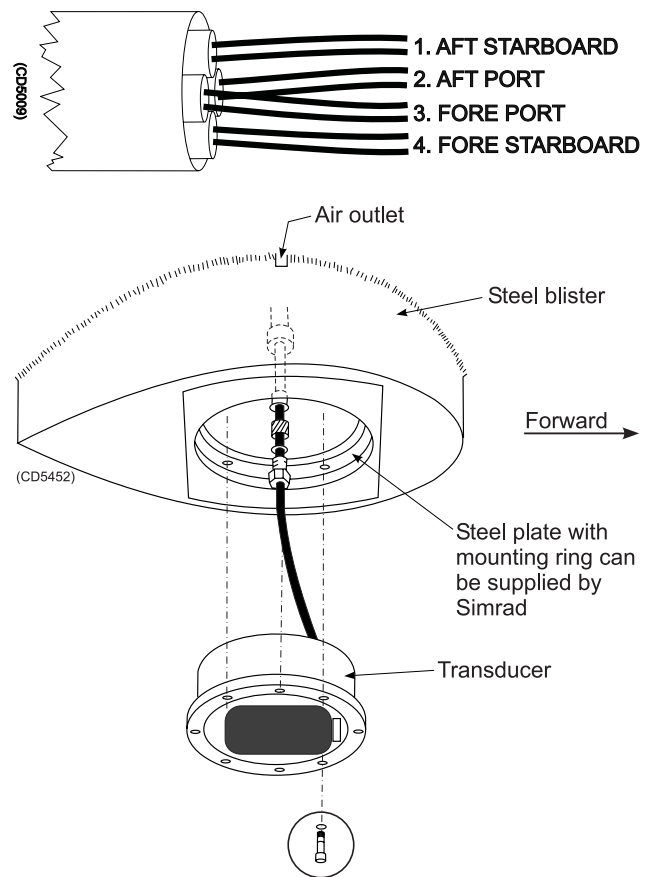
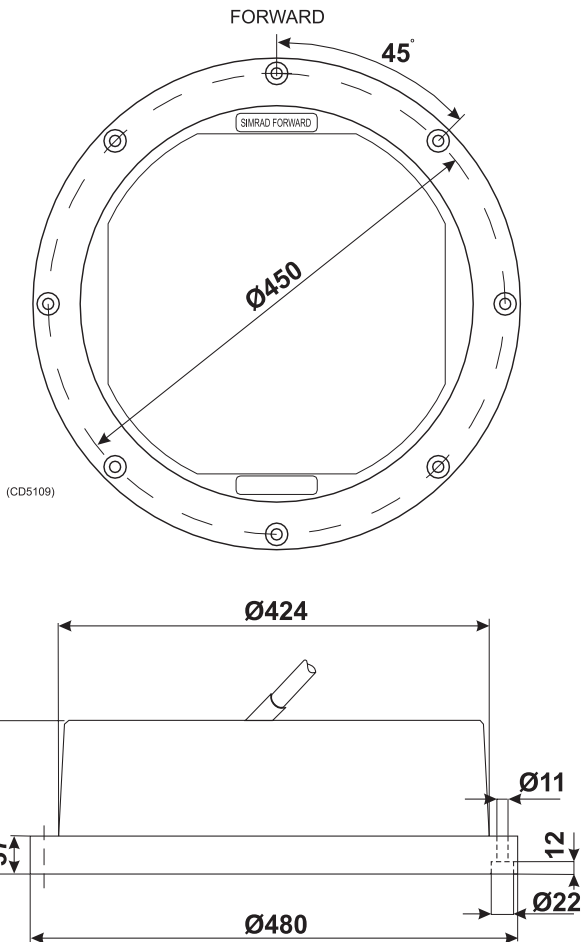

Manufacturer:

Simrad AS
 Strandpromenaden 50
 P.O.Box 111
 N-3191 Horten
 Telephone: +47 33 03 40 00
 Telefax: +47 33 04 29 87
 Internet: www.simrad.com